

ELEPHANT FLUID POWER

大象流体动力



中国·河北·石家庄
Shijiazhuang, Hebei, China

CONTENTS

力士乐系列	REXROTH	01-03
内田系列	UCHIDA	03
萨澳系列	SAUER	03-05
小松系列	KOMATSU	05-07
日立系列	HITACHI	07-09
卡特系列	CATER	09-11
川崎系列	KAWASAKI	11-13
林德系列	LINDE	13-14
伊顿系列	EATON	14-16
不二越系列	NACHI	17
东芝系列	TOSHIBA	17-18
油研系列	YUKEN	18
利勃海尔系列	LIEBHERR	18
卡亚巴系列	KAYABA	18-19
哈威系列	Hawe	20
极东泵	TOKIWA	20
JIC	JIC	20
神钢/加藤	KOBELCO/KATO SERIES	20-21
纳博特斯克	NABTESCO TRAVEL SERIES	21-22
多田野	TADANO SERIES	22
收割机	HARVESTER SERIES	22
控制阀	CONTROL VALVE	23
补油泵	CHARGE PUMP	24-26
马 达	HYDRAULIC MOTOR	27-36
转向器	HYDRAULIC STEERING UNIT	37
多路阀	DIRECTIONAL CONTROL VALVE	38
叶片泵、泵芯	HYDRAULIC VANE PUMP AND SPARE PARTS	39

REXROTH/力士乐系列

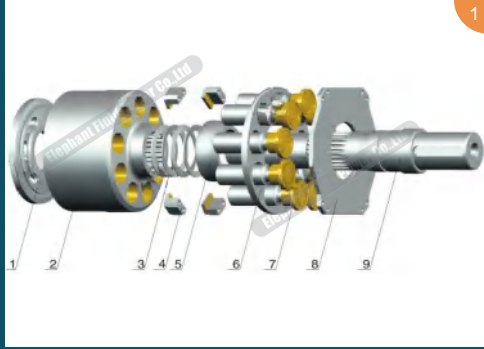

A4V40~250/A4VFO28/A4VSO40~500

NO. 序号	Description 部件名称	Quantity/Set 数量/台
1	Valve Plate (配油盘)	1
2	Cylinder Block (缸体)	1
3	Disk Spring (碟簧)	4
4	Spacer (垫块)	4
5	Ball Guide (球铰)	1
6	Retainer Plate (回程盘)	1
7	Piston Shoe (柱塞滑靴)	9
8	Thrust Plate (止推板)	1
9	Drive Shaft (传动轴)	1

REXROTH/力士乐系列

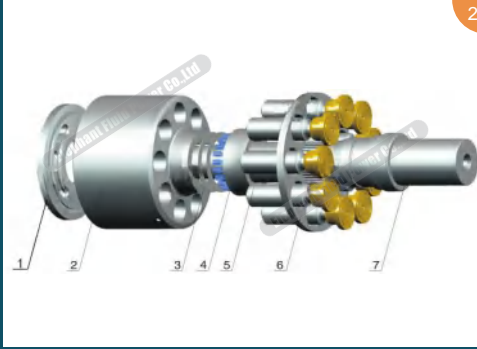

A4VF500/A4VG28-71/A4VTG71/A4VG90-250/A4VHW90

NO. 序号	Description 部件名称	Quantity/Set 数量/台
1	Valve Plate L/R (配油盘)	1
2	Cylinder Block (缸体)	1
3	Disk Spring (碟簧)	4
4	Ball Guide (球铰)	1
5	Piston Shoe (柱塞滑靴)	9
6	Retainer Plate (回程盘)	1
7	Drive Shaft (传动轴)	1
8	Saddle Bearing (月牙轴承)	2

REXROTH/力士乐系列

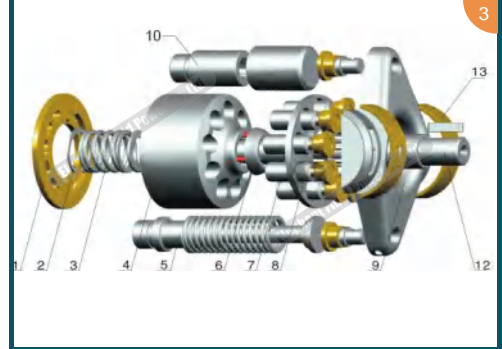

A10VSO16-45/A10VO45/52/A10VSO63-140

NO. 序号	Description 部件名称	Quantity/Set 数量/台
1	Valve Plate L/R/M (配油盘)	1
2	Snap Ring (卡簧)	1
3	Spring (弹簧)	1
4	Cylinder Block (缸体)	1
5	Valve (阀)	1
6	Ball Guide (球铰)	1
7	Piston Shoe (柱塞滑靴)	9
8	Retainer Plate (回程盘)	1
9	Swash Plate (摇摆)	1
10	Control Valve (控制阀)	1
11	Charge Pump (补油泵)	1
12	Drive Shaft (传动轴)	1
13	Saddle Bearing (月牙轴承)	2

REXROTH/力士乐系列

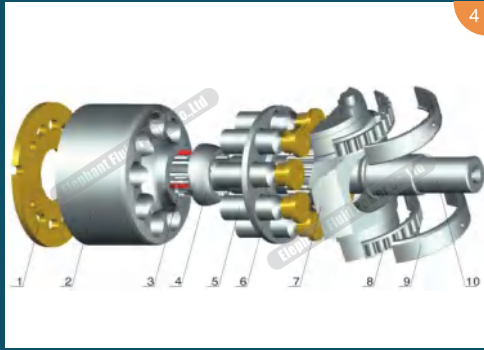

A10VG18-63

NO. 序号	Description 部件名称	Quantity/Set 数量/台
1	Valve Plate L/R/M (配油盘)	1
2	Cylinder Block (缸体)	1
3	Press Pin (顶针)	3
4	Ball Guide (球铰)	1
5	Piston Shoe (柱塞滑靴)	9
6	Retainer Plate (回程盘)	1
7	Swash Plate (摇摆)	1
8	Saddle Bearing (月牙轴承)	2
9	Bearing Seat (月牙轴承座)	2
10	Drive Shaft (传动轴)	1

REXROTH/力士乐系列

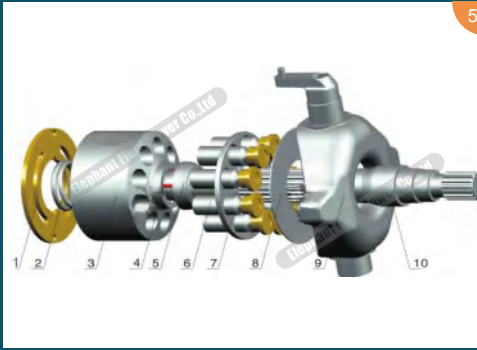

A10V43/63/A10VD40/43

NO. 序号	Description 部件名称	Quantity/Set 数量/台
1	Valve Plate L/R (配油盘)	1
2	Spring (弹簧)	1
3	Cylinder Block (缸体)	1
4	Press Pin (顶针)	3
5	Ball Guide (球铰)	1
6	Piston Shoe (柱塞滑靴)	9
7	Retainer Plate (回程盘)	1
8	Thrust Plate (止推板)	1
9	Swash Plate (摇摆)	1
10	Drive Shaft (传动轴)	1

REXROTH/力士乐系列

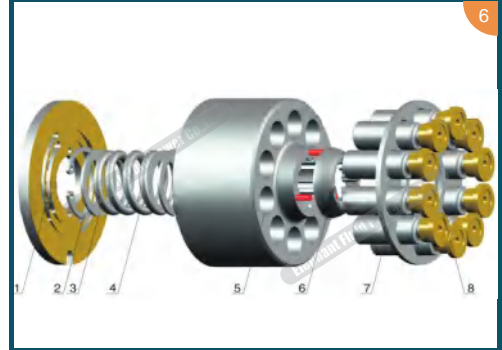

A10VE43/A10VEC60

NO. 序号	Description 部件名称	Quantity/Set 数量/台
1	Valve Plate L/R (配油盘)	1
2	Snap Ring (卡环)	1
3	Spacer (垫块)	2
4	Spring (弹簧)	1
5	Cylinder Block (缸体)	1
6	Ball Guide (球铰)	1
7	Retainer Plate (回程盘)	1
8	Piston Shoe (柱塞滑靴)	10

大象流体动力

Elephant Fluid Power

REXROTH/力士乐系列

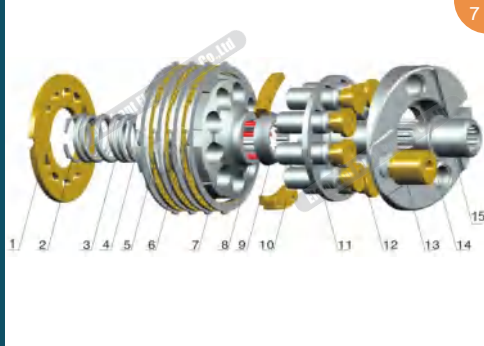

A10VSF28

NO. 序号	Description 部件名称	Quantity/Set 数量/台
1	Valve Plate (配油盘)	1
2	Snap Ring (卡环)	1
3	Spring (弹簧)	1
4	Spacer (垫块)	2
5	Friction Plate (摩擦片)	3
6	Separation Plate (分隔片)	4
7	Cylinder Block (缸体)	1
8	Press Pin (顶针)	3
9	Ball Guide (球铰)	1
10	Retainer (压板)	1
11	Retainer Plate (回程盘)	1
12	Piston Shoe (柱塞滑靴)	9
13	Yoke Piston (支撑柱塞)	1
14	Swash Plate (摇摆)	1
15	Drive Shaft (传动轴)	1

REXROTH/力士乐系列

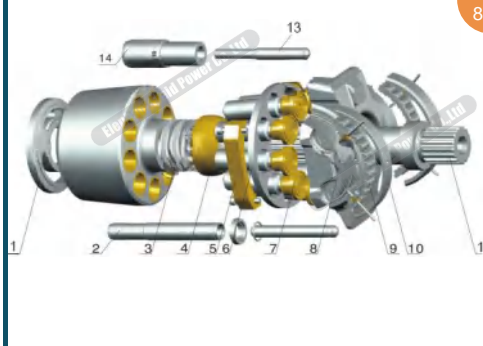

A11VO40/60/75/95/200/250/A11VG35/50/A11V130-190/A11VLO190/260

NO. 序号	Description 部件名称	Quantity/Set 数量/台
1	Valve Plate (配油盘)	1
2	Press Pin (顶针)	1
3	Spacer (垫块)	1
4	Ball Guide (球铰)	1
5	Retainer (压板)	1
6	Retainer Plate (回程盘)	1
7	Piston Shoe (柱塞滑靴)	9
8	Swash Plate (摇摆)	1
9	Saddle Bearing (月牙轴承)	2
10	Bearing Seat (月牙轴承座)	2
11	Drive Shaft (传动轴)	1
12	Cylinder Block (缸体)	1
13	Piston (阀芯)	1
14	Piston Guide (阀套)	1

REXROTH BENT PUMP/力士乐系列斜轴泵

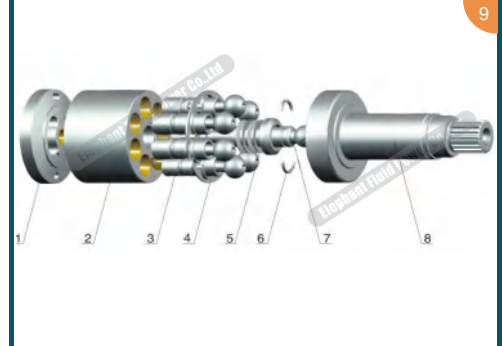

A2F5-1000

NO. 序号	Description 部件名称	Quantity/Set 数量/台
1	Valve Plate (配油盘)	1
2	Cylinder Block (缸体)	1
3	Piston Shoe (柱塞滑靴)	7
4	Retainer Plate (回程盘)	1
5	Disc Spring (碟簧)	4
6	Half Ring (哈夫环)	2
7	Ball Guide (球铰)	1
8	Drive Shaft (传动轴)	1

REXROTH BENT PUMP/力士乐系列斜轴泵

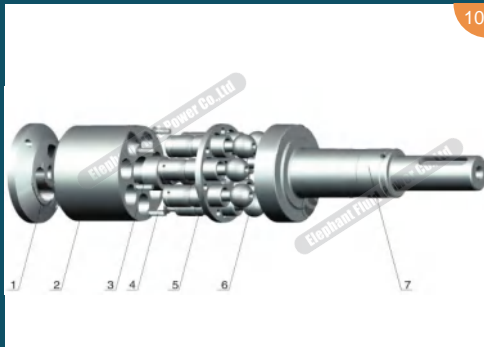

A2VK

NO. 序号	Description 部件名称	Quantity/Set 数量/台
1	Valve Plate L/R (配油盘)	1
2	Cylinder Block (缸体)	1
3	Disk Spring (碟簧)	4
4	Ball Guide (球铰)	1
5	Piston Shoe (柱塞滑靴)	9
6	Retainer Plate (回程盘)	1
7	Drive Shaft (传动轴)	1

REXROTH BENT PUMP/力士乐系列斜轴泵

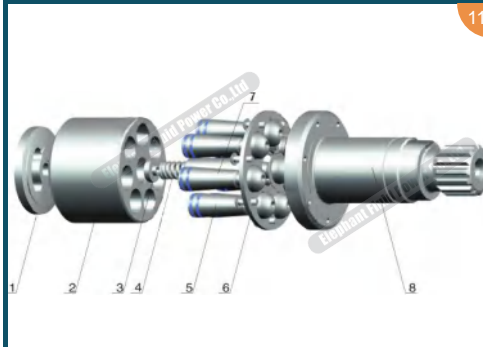

A2FO10-500

NO. 序号	Description 部件名称	Quantity/Set 数量/台
1	Valve Plate (配油盘)	1
2	Cylinder Block (缸体)	1
3	Spring Set (弹簧密封)	1
4	Spring (弹簧)	1
5	Piston Shoe (柱塞滑靴)	7
6	Retainer Plate (回程盘)	1
7	Center Pin (中心柱塞)	1
8	Drive Shaft (传动轴)	1

REXROTH BENT PUMP/力士乐系列斜轴泵

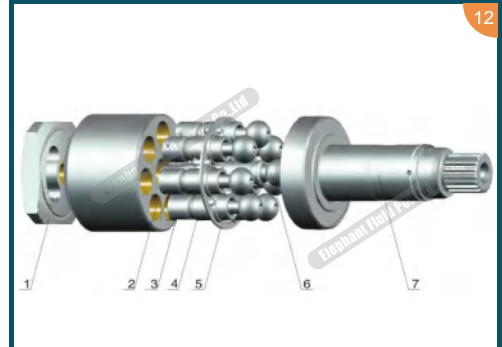

A6V28/A7V55-500

NO. 序号	Description 部件名称	Quantity/Set 数量/台
1	Valve Plate (配油盘)	1
2	Cylinder Block (缸体)	1
3	Disk Spring (碟簧)	4
4	Ball Guide (球铰)	1
5	Piston Shoe (柱塞滑靴)	9
6	Retainer Plate (回程盘)	1
7	Drive Shaft (传动轴)	1

REXROTH BENT PUMP/力士乐系列斜轴泵

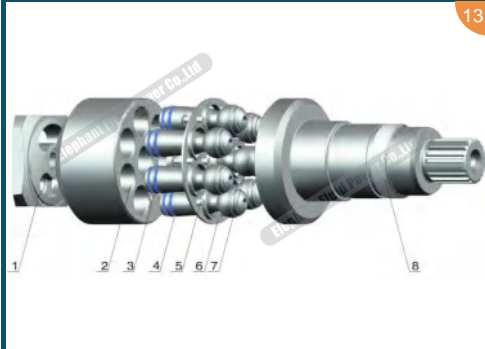

13

A6VM160~500/A6VE160/A7VO28~500

NO. 序号	Description 部件名称	Quantity/Set 数量/台
1	Valve Plate (配油盘)	1
2	Cylinder Block (缸体)	1
3	Ring (柱塞环)	14
4	Piston Shoe (柱塞滑靴)	7
5	Bolt (螺钉)	14
6	Retainer Plate (回程盘)	1
7	Center Pin (中心柱塞)	1
8	Drive Shaft (传动轴)	1

REXROTH-UCHIDA/力士乐-内田系列

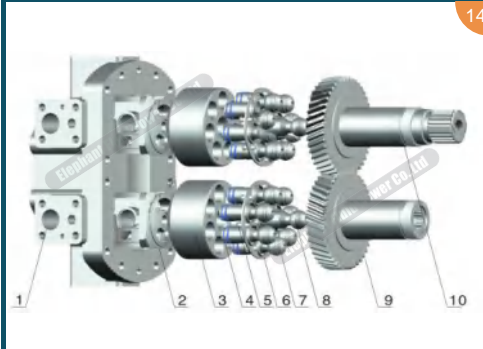

14

A8VO55~200

NO. 序号	Description 部件名称	Quantity/Set 数量/台
1	Cover (盖子)	1
2	Valve Plate L/R (配油盘)	1
3	Cylinder Block (缸体)	2
4	Ring (柱塞环)	28
5	Bolt (螺钉)	14
6	Retainer Plate (回程盘)	2
7	Piston Shoe (柱塞滑靴)	14
8	Center Pin (中心柱塞)	2
9	Drive Shaft L (传动轴)	1
10	Drive Shaft R (传动轴)	1

REXROTH-UCHIDA/力士乐-内田系列

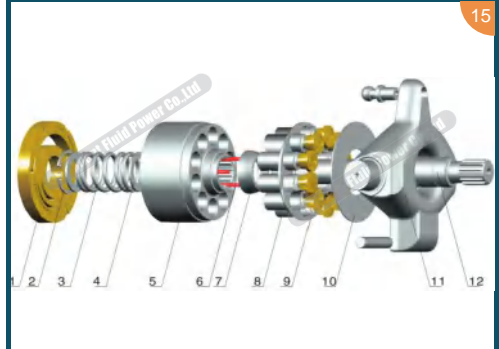

15

AP2D12~36/ZAX70 MAIN PUMP

NO. 序号	Description 部件名称	Quantity/Set 数量/台
1	Valve Plate L/R (配油盘)	1
2	Snap Ring (卡环)	1
3	Spring (弹簧)	1
4	Spacer (垫块)	2
5	Cylinder Block (缸体)	1
6	Press Pin (顶针)	3
7	Ball Guide (球铰)	1
8	Piston Shoe (柱塞滑靴)	10
9	Retainer Plate (回程盘)	1
10	Thrust Plate (止推板)	1
11	Swash Plate (摇摆)	1
12	Drive Shaft (传动轴)	1

SAUER/萨澳系列

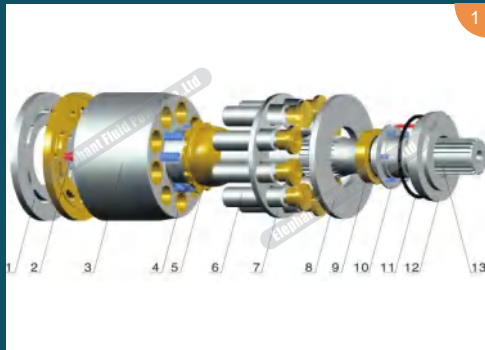

1

PV20~112/SPV6/119/OPV27

NO. 序号	Description 部件名称	Quantity/Set 数量/台
1	Valve Plate L/R/M (配油盘)	1
2	Pin (顶针)	1
3	Cylinder Block (缸体)	1
4	Spring (弹簧)	6
5	Ball Guide (球铰)	1
6	Piston Shoe (柱塞滑靴)	9
7	Retainer Plate (回程盘)	1
8	Thrust Plate (止推板)	1
9	Shaft Seal Set (轴封)	1
10	Shaft Seal Set (轴封)	1
11	O Ring (密封)	1
12	Seal Seat (密封)	1
13	Drive Shaft (传动轴)	1

SAUER/萨澳系列

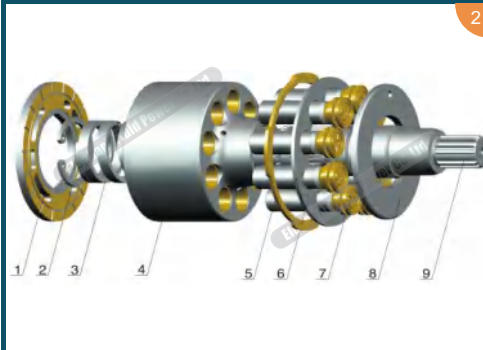

2

PVD45/TB35/45

NO. 序号	Description 部件名称	Quantity/Set 数量/台
1	Valve Plate (配油盘)	1
2	Snap Ring (卡环)	1
3	Spring (弹簧)	1
4	Cylinder Block (缸体)	1
5	Retainer (压板)	1
6	Retainer Plate (回程盘)	1
7	Piston Shoe (柱塞滑靴)	9
8	Thrust Plate (止推板)	1
9	Drive Shaft (传动轴)	1

SAUER/萨澳系列

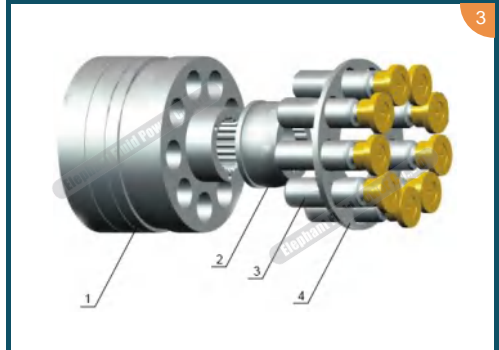

3

MF16A/MF035/MF500

NO. 序号	Description 部件名称	Quantity/Set 数量/台
1	Cylinder Block (缸体)	1
2	Ball Guide (球铰)	1
3	Piston Shoe (柱塞滑靴)	9
4	Retainer Plate (回程盘)	1
5	Valve Plate L/R (配油盘)	1

大象流体动力

Elephant Fluid Power

SAUER/萨澳系列

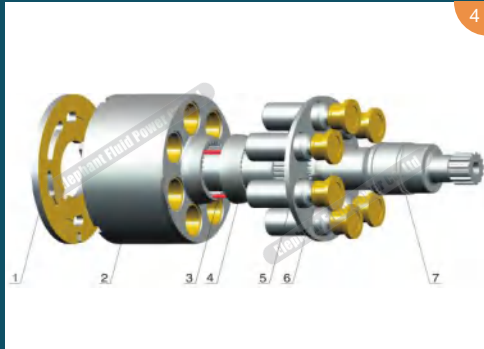

MPV046/M46

NO. 序号	Description 部件名称	Quantity/Set 数量/台
1	Valve Plate (配油盘)	1
2	Cylinder Block (缸体)	1
3	Press Pin (顶针)	3
4	Ball Guide (球铰)	1
5	Piston Shoe (柱塞滑靴)	7
6	Retainer Plate (回程盘)	1
7	Drive Shaft (传动轴)	1

SAUER/萨澳系列

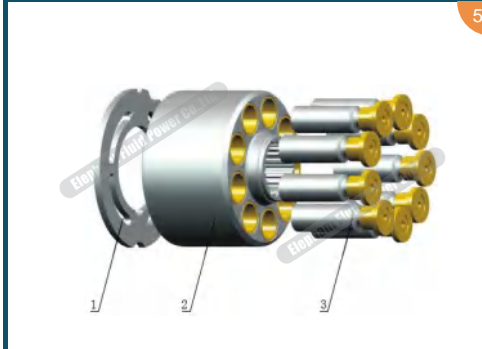

MPR63

NO. 序号	Description 部件名称	Quantity/Set 数量/台
1	Valve Plate (配油盘)	1
2	Cylinder Block (缸体)	1
3	Piston Shoe (柱塞滑靴)	7

SAUER/萨澳系列

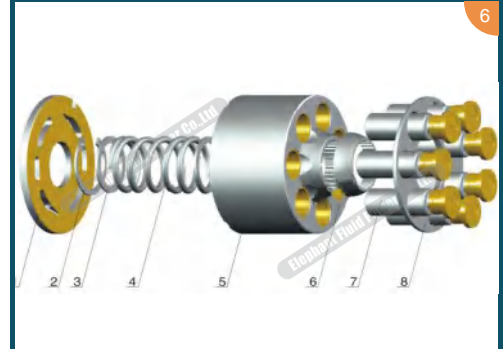

MPV45

NO. 序号	Description 部件名称	Quantity/Set 数量/台
1	Valve Plate (配油盘)	1
2	Snap Ring (卡环)	1
3	Washer (垫圈)	2
4	Coil Spring (大弹簧)	1
5	Cylinder Block (缸体)	1
6	Ball Guide (球铰)	1
7	Piston Shoe (柱塞滑靴)	7
8	Retainer Plate (回程盘)	1

SAUER 90/萨澳 90 系列

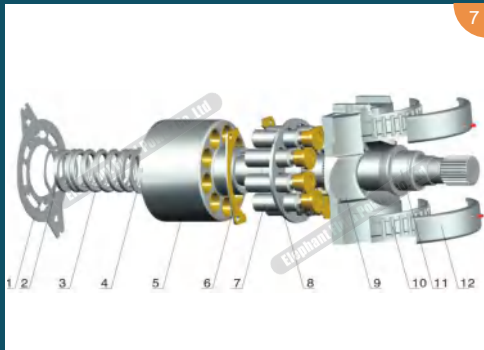

PV90R030-250

NO. 序号	Description 部件名称	Quantity/Set 数量/台
1	Valve Plate L/R/M (配油盘)	1
2	Snap Ring (卡环)	1
3	Spring (弹簧)	1
4	Washer (垫圈)	2
5	Cylinder Block (缸体)	1
6	Retainer (压板)	2
7	Piston Shoe (柱塞滑靴)	9
8	Retainer Plate (回程盘)	1
9	Swash Plate (摇摆)	1
10	Saddle Bearing (月牙轴承)	2
11	Drive Shaft (传动轴)	1
12	Bearing Seat (月牙轴承座)	2

SAUER 90/萨澳 90 系列

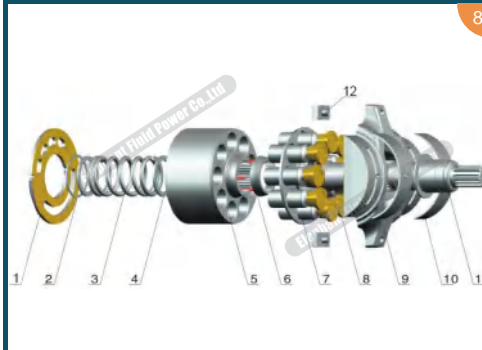

BRL100

NO. 序号	Description 部件名称	Quantity/Set 数量/台
1	Valve Plate (配油盘)	1
2	Snap Ring (卡环)	1
3	Spring (弹簧)	1
4	Washer (垫圈)	2
5	Cylinder Block (缸体)	1
6	Ball Guide (球铰)	1
7	Retainer Plate (回程盘)	1
8	Piston Shoe (柱塞滑靴)	9
9	Swash Plate (摇摆)	1
10	Saddle Bearing (月牙轴承)	2
11	Drive Shaft (传动轴)	1
12	Yoke Piston (支撑柱塞)	2

SAUER 90/萨澳 90 系列

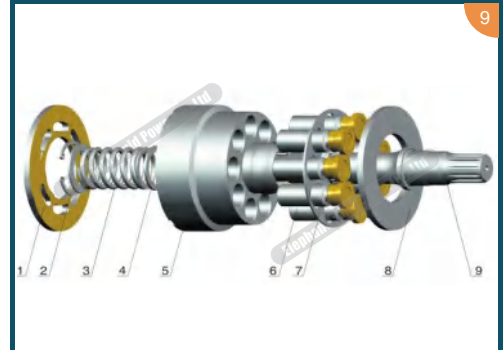

SPV14/SPV15/SPV18/MMFO25C

NO. 序号	Description 部件名称	Quantity/Set 数量/台
1	Valve Plate L/R (配油盘)	1
2	Snap Ring (卡环)	1
3	Spring (弹簧)	1
4	Washer (垫圈)	2
5	Cylinder Block (缸体)	1
6	Piston Shoe (柱塞滑靴)	9
7	Retainer Plate (回程盘)	1
8	Thrust Plate (止推板)	1
9	Drive Shaft (传动轴)	1

SAUER 90/萨澳 90 系列

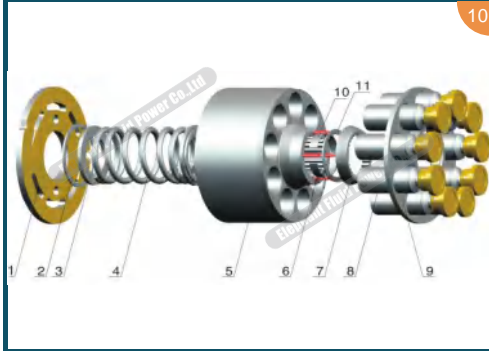

MPT044/M44

NO. 序号	Description 部件名称	Quantity/Set 数量/台
1	Valve Plate (配油盘)	1
2	Snap Ring (卡环)	1
3	Washer (垫圈)	2
4	Spring (弹簧)	1
5	Cylinder Block (缸体)	1
6	Press Pin (顶针)	3
7	Ball Guide (球铰)	1
8	Piston Shoe (柱塞滑靴)	9
9	Retainer Plate (回程盘)	1
10	Back-UP Spring (备用弹簧)	1
11	Washer (垫圈)	1

SAUER 90/萨澳 90 系列

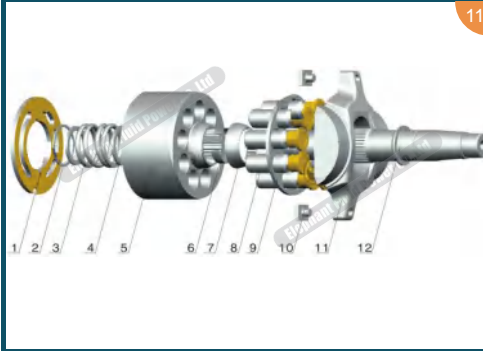

HRR057

NO. 序号	Description 部件名称	Quantity/Set 数量/台
1	Valve Plate (配油盘)	1
2	Snap Ring (卡环)	1
3	Spring (弹簧)	1
4	Washer (垫圈)	1
5	Cylinder Block (缸体)	1
6	Back-UP Spring (备用弹簧)	1
7	Ball Guide (球铰)	1
8	Piston Shoe (柱塞滑靴)	9
9	Retainer Plate (回程盘)	1
10	Yoke Piston (支撑柱塞)	2
11	Swash Plate (摇摆)	1
12	Drive Shaft (传动轴)	1

KOMATSU EXCAVATOR/小松系列

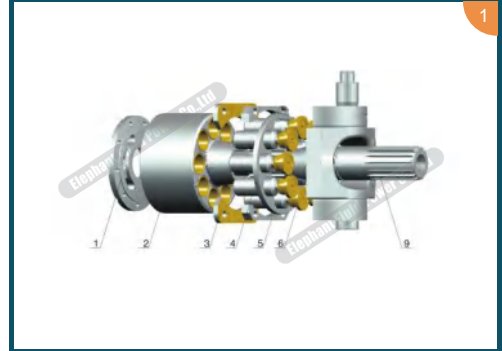

HPV35/HPV55/HPV90/HPV160/PC50/PC400-7

NO. 序号	Description 部件名称	Quantity/Set 数量/台
1	Valve Plate L/R (配油盘)	1
2	Cylinder Block (缸体)	1
3	Retainer (压板)	2
4	Spacer (垫块)	2
5	Piston Shoe (柱塞滑靴)	9
6	Retainer Plate (回程盘)	1
7	Swash Plate (摇摆)	1
8	Support (摇摆座)	1
9	Drive Shaft (传动轴)	1

KOMATSU EXCAVATOR/小松系列

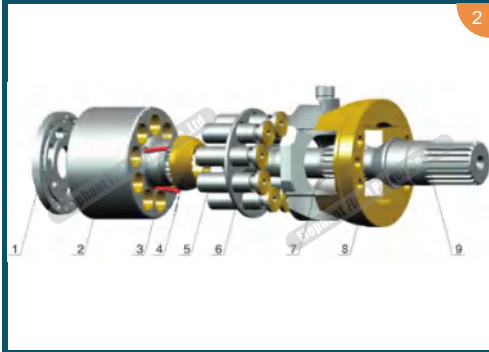

HPV95/132/PC360-7/PC200-8/240-8/PC1250

NO. 序号	Description 部件名称	Quantity/Set 数量/台
1	Valve Plate L/R (配油盘)	1
2	Cylinder Block (缸体)	1
3	Press Pin (顶针)	3
4	Ball Guide (球铰)	1
5	Retainer Plate (回程盘)	1
6	Piston Shoe (柱塞滑靴)	9
7	Swash Plate (摇摆)	1
8	Support (摇摆座)	1
9	Drive Shaft (传动轴)	1
10	Charge Pump (补油泵)	1

KOMATSU EXCAVATOR/小松系列

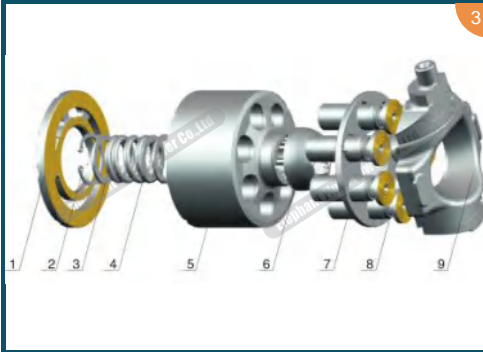

PC300U

NO. 序号	Description 部件名称	Quantity/Set 数量/台
1	Valve Plate (配油盘)	1
2	Snap Ring (卡环)	1
3	Washer (垫圈)	2
4	Coil Spring (大弹簧)	1
5	Cylinder Block (缸体)	1
6	Ball Guide (球铰)	1
7	Retainer Plate (回程盘)	1
8	Piston Shoe (柱塞滑靴)	7
9	Swash Plate (摇摆)	1

KOMATSU EXCAVATOR/小松系列

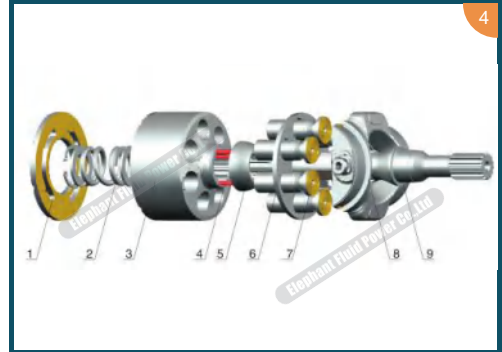

PC40-8/PC60-7

NO. 序号	Description 部件名称	Quantity/Set 数量/台
1	Valve Plate (配油盘)	1
2	Spring (弹簧)	1
3	Cylinder Block (缸体)	1
4	Press Pin (顶针)	3
5	Ball Guide (球铰)	1
6	Retainer Plate (回程盘)	1
7	Piston Shoe (柱塞滑靴)	7/9
8	Swash Plate (摇摆)	1
9	Drive Shaft (传动轴)	1

大象流体动力

Elephant Fluid Power

KOMATSU EXCAVATOR/小松系列

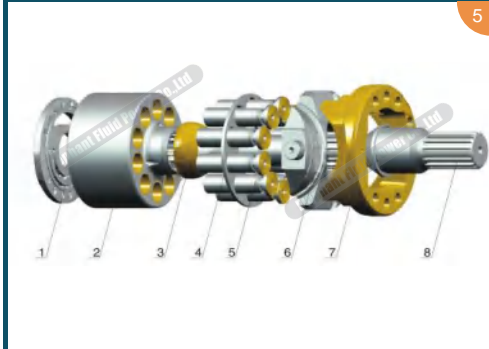

PC160

NO. 序号	Description 部件名称	Quantity/Set 数量/台
1	Valve Plate (配油盘)	1
2	Cylinder Block (缸体)	1
3	Ball Guide (球铰)	1
4	Retainer Plate (回程盘)	1
5	Piston Shoe (柱塞滑靴)	9
6	Swash Plate (摇摆)	1
7	Support (摇摆座)	1
8	Drive Shaft (传动轴)	1

KOMATSU EXCAVATOR/小松系列

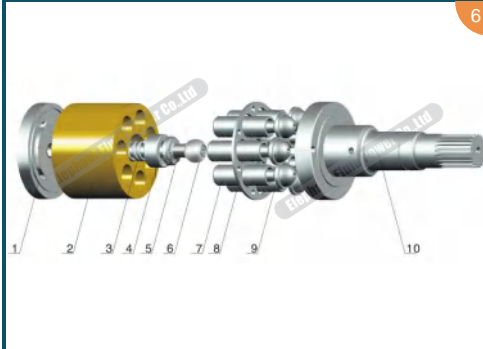

PC200-2/PC60-6

NO. 序号	Description 部件名称	Quantity/Set 数量/台
1	Valve Plate (配油盘)	1
2	Cylinder Block (缸体)	1
3	Spring (弹簧)	1
4	Washer (垫圈)	1
5	Center Pin (中心柱塞)	1
6	Center Ball (中心柱塞)	1
7	Piston Shoe (柱塞滑靴)	7
8	Retainer Plate (回程盘)	1
9	Spherical Washer (球形垫圈)	7
10	Drive Shaft (传动轴)	1

KOMATSU EXCAVATOR/小松系列

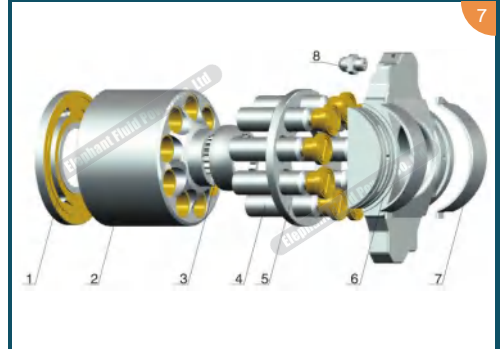

PC320

NO. 序号	Description 部件名称	Quantity/Set 数量/台
1	Valve Plate (配油盘)	1
2	Cylinder Block (缸体)	1
3	Ball Guide (球铰)	1
4	Piston Shoe (柱塞滑靴)	9
5	Retainer Plate (回程盘)	1
6	Swash Plate (摇摆)	1
7	Saddle Bearing (月牙轴承)	2
8	Yoke Piston (支撑柱塞)	1

KOMATSU EXCAVATOR/小松系列

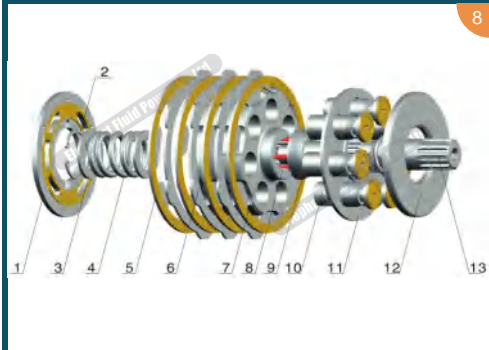

PC45R-8/60-7 SWING MOTOR

NO. 序号	Description 部件名称	Quantity/Set 数量/台
1	Valve Plate (配油盘)	1
2	Snap Ring (卡簧)	1
3	Washer (垫圈)	1
4	Coli Spring (大弹簧)	1
5	Friction Plate (摩擦片)	2
6	Seperation Plate (分隔片)	3
7	Cylinder Block (缸体)	1
8	Press Pin (顶针)	3
9	Ball Guide (球铰)	1
10	Piston Shoe (柱塞滑靴)	7
11	Retainer Plate (回程盘)	1
12	Thrust Plate (止推板)	1
13	Drive Shaft (传动轴)	1

KOMATSU EXCAVATOR/小松系列

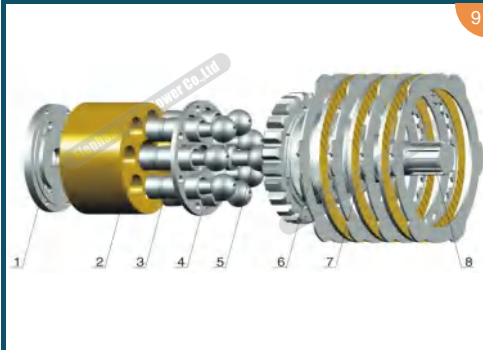

PC120-6 SWING MOTOR

NO. 序号	Description 部件名称	Quantity/Set 数量/台
1	Valve Plate (配油盘)	1
2	Cylinder Block (缸体)	1
3	Piston Shoe (柱塞滑靴)	7
4	Retainer Plate (回程盘)	1
5	Center Pin (中心柱塞)	1
6	Seperation Plate (分隔片)	4
7	Friction Plate (摩擦片)	3
8	Drive Shaft (传动轴)	1
9	Control Valve (控制阀)	1

KOMATSU EXCAVATOR/小松系列

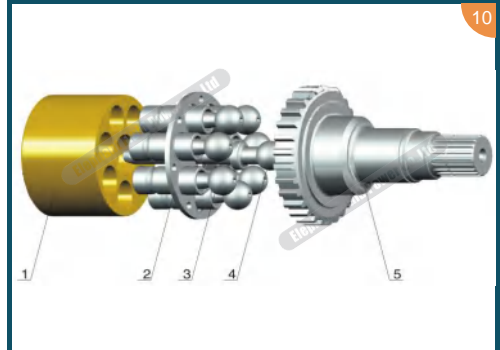

PC200-6/PC450 SWING MOTOR
LMF45/HPV220-8 SWING MOTOR

NO. 序号	Description 部件名称	Quantity/Set 数量/台
1	Cylinder Block (缸体)	1
2	Retainer Plate (回程盘)	1
3	Piston Shoe (柱塞滑靴)	7
4	Center Pin (中心柱塞)	1
5	Drive Shaft (传动轴)	1
6	Friction Plate (摩擦片)	3
7	Seperation Plate (分隔片)	4

KOMATSU EXCAVATOR/小松系列

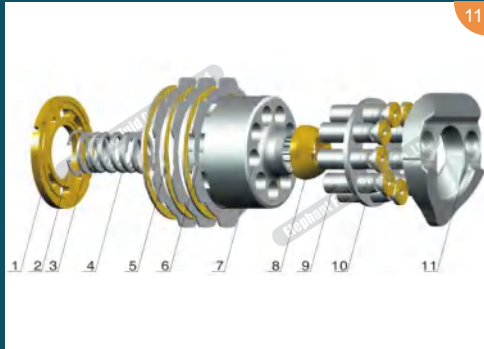

PC200-7 TRAVEL MOTOR

NO. 序号	Description 部件名称	Quantity/Set 数量/台
1	Valve Plate M (配油盘)	1
2	Snap Ring (卡簧)	1
3	Washer (垫圈)	2
4	Coli Spring (大弹簧)	1
5	Friction Plate (摩擦片)	3
6	Seperation Plate (分隔片)	4
7	Cylinder Block (缸体)	1
8	Ball Guide (球铰)	1
9	Piston Shoe (柱塞滑靴)	9
10	Retainer Plate (回程盘)	1
11	Swash Plate (摇摆)	1

KOMATSU EXCAVATOR/小松系列

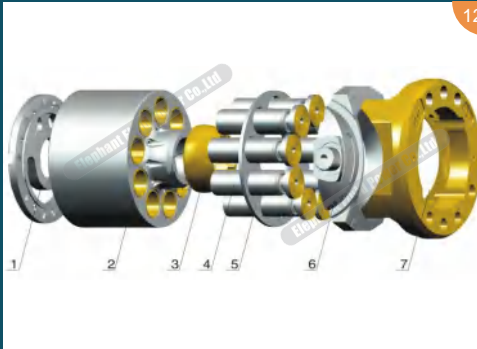

PC400-7 TRAVEL MOTOR

NO. 序号	Description 部件名称	Quantity/Set 数量/台
1	Valve Plate M (配油盘)	1
2	Cylinder Block (缸体)	1
3	Retainer Plate (回程盘)	1
4	Piston Shoe (柱塞滑靴)	7
5	Retainer Plate (回程盘)	1
6	Swash Plate (摇摆)	1
7	Support (摇摆座)	1

HITACHI/日立系列

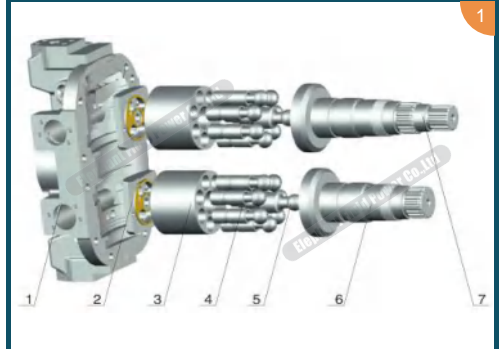

HPV050 /HPV102(EX200-5/6)/ HPV118 (ZX200-3、ZX270 MAIN PUMP)

NO. 序号	Description 部件名称	Quantity/Set 数量/台
1	Rear Cover (后盖)	1
2	Valve Plate L/R (配油盘)	2
3	Cylinder Block (缸体)	2
4	Piston Shoe (柱塞滑靴)	18
5	Center Pin (中心柱塞)	2
6	Driven Shaft (从动轴)	1
7	Drive Shaft (传动轴)	1
8	Charge Pump (补油泵)	1

HITACHI/日立系列

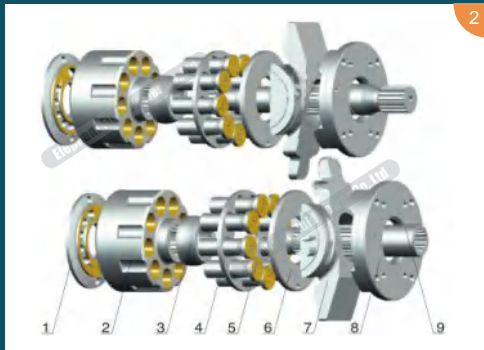

ZX120-6 MAIN PUMP(HPK055)

NO. 序号	Description 部件名称	Quantity/Set 数量/台
1	Valve Plate (配油盘)	1
2	Cylinder Block (缸体)	1
3	Ball Guide (球铰)	1
4	Retainer Plate (回程盘)	1
5	Piston Shoe (柱塞滑靴)	9
6	Thrust Plate (止推板)	1
7	Swash Plate (摇摆)	1
8	Support (摇摆座)	1
9	Drive Shaft (传动轴)	1

HITACHI/日立系列

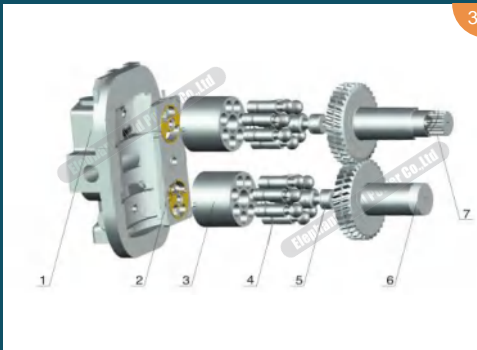

HPV091(EX200-2/3, EX120-2 PUMP)

NO. 序号	Description 部件名称	Quantity/Set 数量/台
1	Rear Cover (后盖)	1
2	Valve Plate (配油盘)	2
3	Cylinder Block (缸体)	2
4	Piston Shoe (柱塞滑靴)	14
5	Center Pin (中心柱塞)	2
6	Driven Shaft (从动轴)	1
7	Drive Shaft (传动轴)	1
8	Charge Pump (补油泵)	1

HITACHI/日立系列

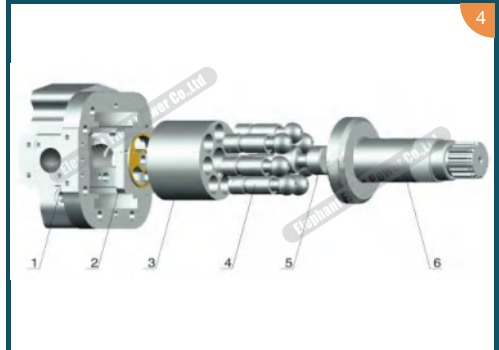

HPV116/145/125B

NO. 序号	Description 部件名称	Quantity/Set 数量/台
1	Rear Cover (后盖)	1
2	Valve Plate (配油盘)	1
3	Cylinder Block (缸体)	1
4	Piston Shoe (柱塞滑靴)	7
5	Center Pin (中心柱塞)	1
6	Drive Shaft (传动轴)	1
7	Valve Plate bolt (阀板螺钉)	2
8	Charge Pump (补油泵)	1

大象流体动力

Elephant Fluid Power

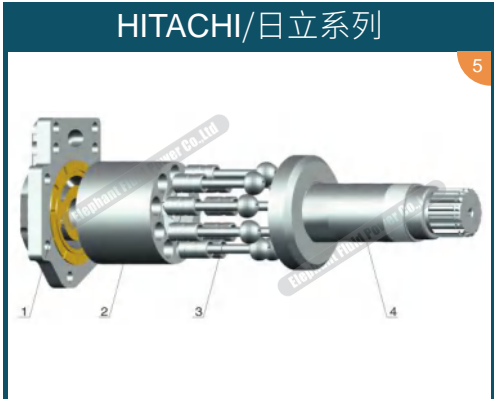

HPV125A/B			
NO. 序号	Description 部件名称	Quantity/Set 数量/台	
1	Valve Plate (配油盘)	1	
2	Cylinder Block (缸体)	1	
3	Piston Shoe (柱塞滑靴)	9	
4	Drive Shaft (传动轴)	1	
5	Center Pin (中心柱塞)	1	

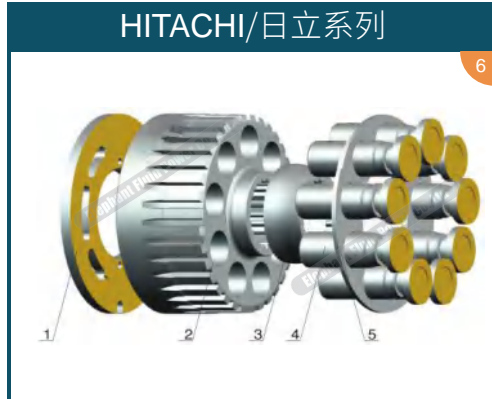

EX60-2/3 SWING MOTOR			
NO. 序号	Description 部件名称	Quantity/Set 数量/台	
1	Valve Plate (配油盘)	1	
2	Cylinder Block (缸体)	1	
3	Piston Shoe (柱塞滑靴)	9	
4	Drive Shaft (传动轴)	1	
5	Retainer Plate (回程盘)	1	

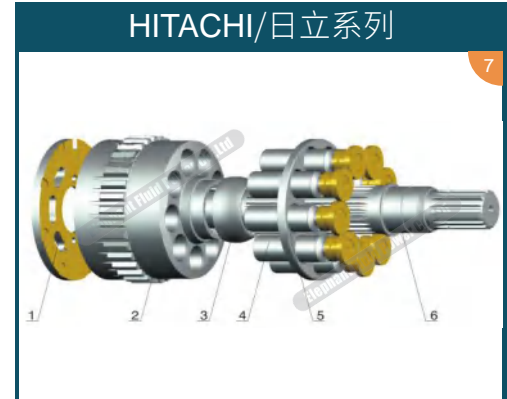

EX105-2 MOTOR/EX120-2 SWING MOTOR EX120-5 SWING MOTOR			
NO. 序号	Description 部件名称	Quantity/Set 数量/台	
1	Valve Plate (配油盘)	1	
2	Cylinder Block (缸体)	1	
3	Ball Guide (球铰)	1	
4	Piston Shoe (柱塞滑靴)	9	
5	Retainer Plate (回程盘)	1	
6	Drive Shaft (传动轴)	1	

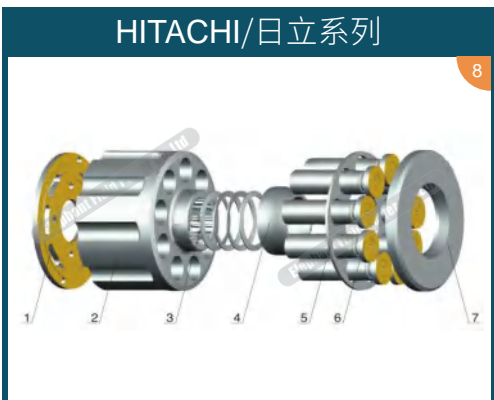

ZAX120 SWING MOTOR			
NO. 序号	Description 部件名称	Quantity/Set 数量/台	
1	Valve Plate M (配油盘)	1	
2	Cylinder Block (缸体)	1	
3	Ball Guide Washer (球铰垫圈)	4	
4	Ball Guide (球铰)	1	
5	Retainer Plate (回程盘)	1	
6	Piston Shoe (柱塞滑靴)	9	
7	Thrust Plate (止推板)	1	

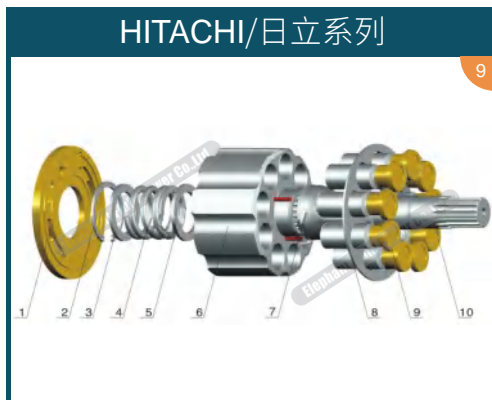

EM56 TRAVEL MOTOR			
NO. 序号	Description 部件名称	Quantity/Set 数量/台	
1	Valve Plate M (配油盘)	1	
2	Snap Ring (卡环)	1	
3	Washer Nether (下垫圈)	1	
4	Coil Spring (大弹簧)	1	
5	Washer Up (上垫圈)	1	
6	Cylinder Block (缸体)	1	
7	Ball Guide (球铰)	1	
8	Piston Shoe (柱塞滑靴)	9	
9	Retainer Plate (回程盘)	1	
10	Drive Shaft (传动轴)	1	

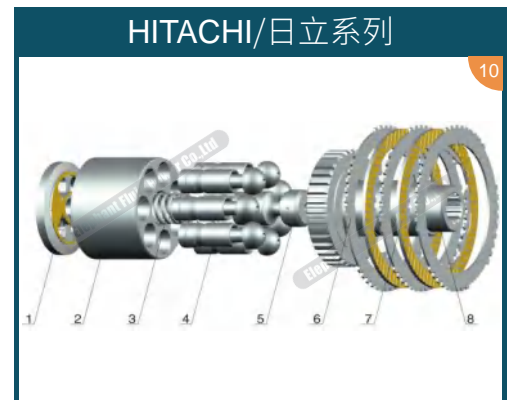

HMGC16/32/35			
NO. 序号	Description 部件名称	Quantity/Set 数量/台	
1	Valve Plate (配油盘)	1	
2	Cylinder Block (缸体)	1	
3	Spring (弹簧)	1	
4	Piston Shoe (柱塞滑靴)	7	
5	Center Pin (中心柱塞)	1	
6	Friction Plate (摩擦片)	3	
7	Seperation Plate (分隔片)	2	
8	Drive Shaft (传动轴)	1	

HITACHI/日立系列

11

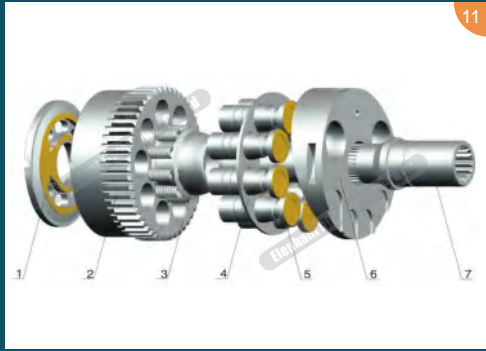

EX550-3 TRAVEL MOTOR

NO. 序号	Description 部件名称	Quantity/Set 数量/台
1	Valve Plate M (配油盘)	1
2	Cylinder Block (缸体)	1
3	Ball Guide (球铰)	1
4	Retainer Plate (回程盘)	1
5	Piston Shoe (柱塞滑靴)	9
6	Swash Plate (摇摆)	1
7	Drive Shaft (传动轴)	1

HITACHI/日立系列

12

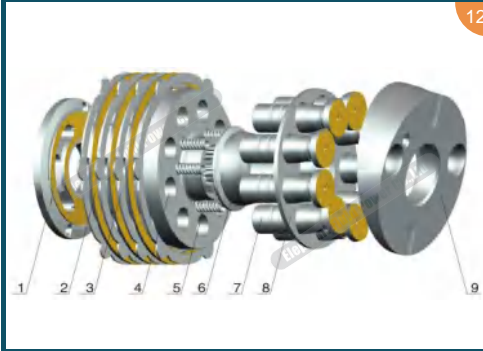

HMGE36EA(ZX200 TRAVEL MOTOR)

NO. 序号	Description 部件名称	Quantity/Set 数量/台
1	Valve Plate M (配油盘)	1
2	Friction Plate (摩擦片)	3
3	Seperation Plate (分隔片)	4
4	Cylinder Block (缸体)	1
5	Spring (弹簧)	6
6	Ball Guide (球铰)	1
7	Piston Shoe (柱塞滑靴)	9
8	Drive Shaft (传动轴)	1
9	Swash Plate (摇摆)	1

HITACHI/日立系列

13

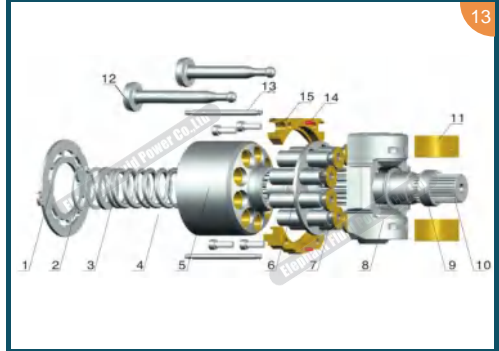

HMF160/200

NO. 序号	Description 部件名称	Quantity/Set 数量/台
1	Valve Plate M (配油盘)	1
2	Snap Ring (卡环)	1
3	Coil Spring (弹簧)	1
4	Washer (垫圈)	2
5	Cylinder Block (缸体)	1
6	Retainer Plate (回程盘)	1
7	Piston Shoe (柱塞滑靴)	9
8	Swash Plate (摇摆)	1
9	Drive Shaft Sleeve (传动轴套)	1
10	Drive Shaft (传动轴)	1
11	Saddle Bearing (轴瓦)	1
12	Servo Piston (伺服活塞)	1
13	Press Pin (顶针)	2
14	Retainer Bolt (压板螺钉)	4
15	Retainer (压板)	2

HITACHI/日立系列

14

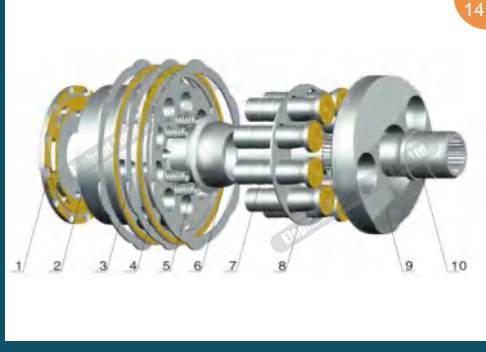

ZX330-2 TRAVEL MOTOR

NO. 序号	Description 部件名称	Quantity/Set 数量/台
1	Valve Plate (配油盘)	1
2	Cylinder Block (缸体)	1
3	Seperation Plate (分隔片)	3
4	Friction Plate (摩擦片)	4
5	Spring (弹簧)	6
6	Ball Guide (球铰)	1
7	Piston Shoe (柱塞滑靴)	9
8	Retainer Plate (回程盘)	1
9	Swash Plate (摇摆)	1
10	Drive Shaft (传动轴)	1

CAT/卡特系列

1

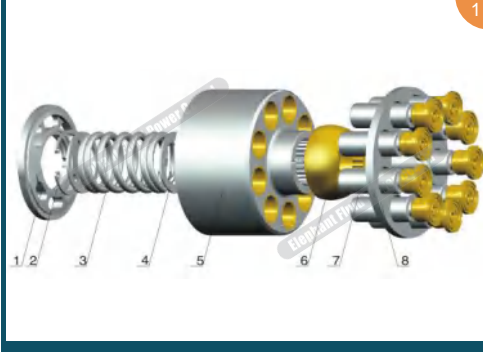

VRD63(CAT120)DOUBLE PUMP

NO. 序号	Description 部件名称	Quantity/Set 数量/台
1	Valve Plate (配油盘)	2
2	Snap Ring (卡环)	2
3	Spring (弹簧)	2
4	Washer (垫圈)	4
5	Cylinder Block (缸体)	2
6	Ball Guide (球铰)	2
7	Piston Shoe (柱塞滑靴)	18
8	Retainer Plate (回程盘)	2
9	Swash Plate (摇摆)	2
10	Support (摇摆座)	2

CAT/卡特系列

2

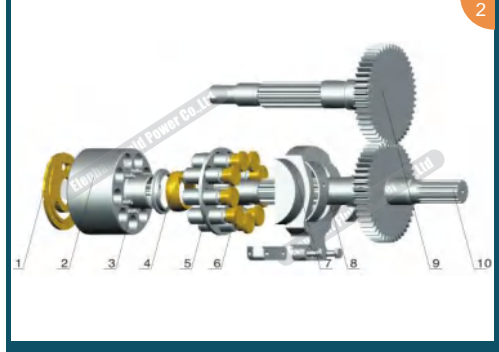

SBS80(CAT312C)

NO. 序号	Description 部件名称	Quantity/Set 数量/台
1	Valve Plate L/R (配油盘)	1
2	Cylinder Block (缸体)	2
3	Ball Guide Spring (球铰弹簧)	6
4	Ball Guide (球铰)	2
5	Retainer Plate (回程盘)	2
6	Piston Shoe (柱塞滑靴)	18
7	Swash Plate (摇摆)	9
8	Saddle Bearing (轴瓦)	1
9	Driven Shaft (从动轴)	1
10	Drive Shaft (传动轴)	1

大象流体动力

Elephant Fluid Power

CAT/卡特系列

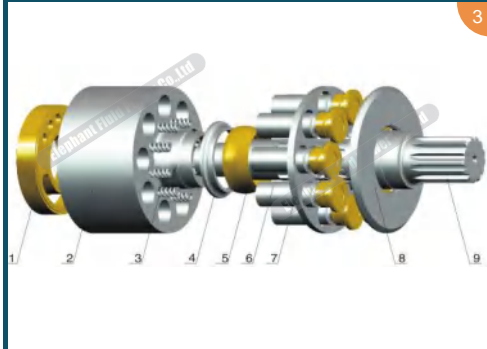

E200B/AP-12/14/SPK10/10

NO. 序号	Description 部件名称	Quantity/Set 数量/台
1	Valve Plate (配油盘)	1
2	Cylinder Block (缸体)	2
3	Spring (弹簧)	18
4	Washer (垫圈)	2
5	Ball Guide (球铰)	2
6	Piston Shoe (柱塞滑靴)	18
7	Retainer Plate (回程盘)	2
8	Thrust Plate (止推板)	2
9	Drive Shaft (传动轴)	1
10	Axial Shaft (传动轴)	4
11	Bearing (轴承)	4
12	Charge Pump (补油泵)	1

CAT/卡特系列

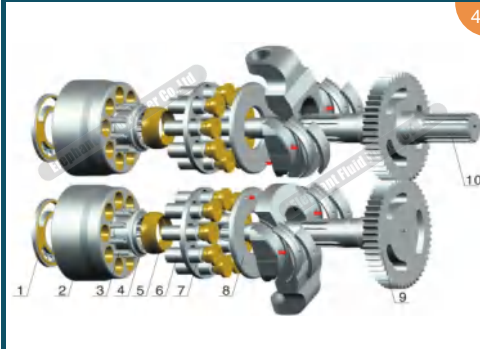

CAT320C DOUBLE PUMP

NO. 序号	Description 部件名称	Quantity/Set 数量/台
1	Valve Plate L/R (配油盘)	1
2	Cylinder Block (缸体)	2
3	Spring (弹簧)	18
4	Washer (垫圈)	2
5	Ball Guide (球铰)	2
6	Piston Shoe (柱塞滑靴)	18
7	Retainer Plate (回程盘)	2
8	Thrust Plate (止推板)	2
9	Driven Shaft (从动轴)	1
10	Drive Shaft (传动轴)	1
11	Axial Shaft (传动轴)	4
12	Bearing (轴承)	4
13	Servo Piston (伺服活塞)	1

CAT/卡特系列

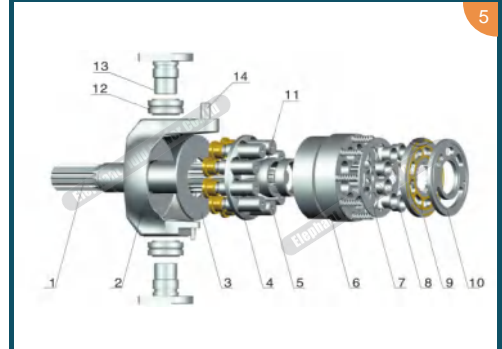

SPV10/10(MS180)DOUBLE PUMP

NO. 序号	Description 部件名称	Quantity/Set 数量/台
1	Drive Shaft (传动轴)	1
2	Swash Plate (摇摆)	1
3	Thrust Plate (止推板)	2
4	Retainer Plate (回程盘)	2
5	Piston Shoe (柱塞滑靴)	18
6	Cylinder Block (缸体)	2
7	Retainer Plate (回程盘)	2
8	Drum Seal (鼓封)	1
9	Bearing Plate (衬板)	2
10	Valve Plate L/R (配油盘)	1
11	Ball Guide (球铰)	2
12	Bearing (轴承)	2
13	Axial Shaft (传动轴)	4
14	Pin 1/ Pin 2 (顶针)	1

CAT/卡特系列

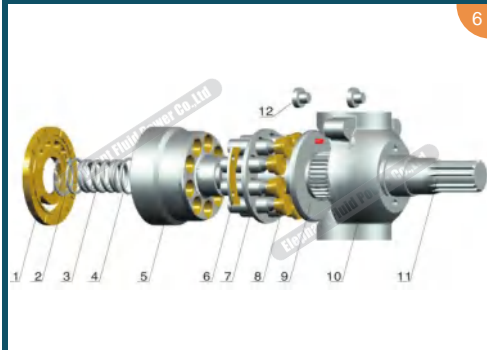

CAT12G/14G/16G

NO. 序号	Description 部件名称	Quantity/Set 数量/台
1	Valve Plate (配油盘)	1
2	Snap Ring (卡环)	1
3	Coil Spring (大弹簧)	1
4	Washer (垫圈)	2
5	Cylinder Block (缸体)	1
6	Retainer (压板)	1
7	Retainer Plate (回程盘)	1
8	Piston Shoe (柱塞滑靴)	9
9	Thrust Plate (止推板)	1
10	Swash Plate (摇摆)	1
11	Drive Shaft (传动轴)	1
12	Locating Pin (定位销)	2

CAT/卡特系列

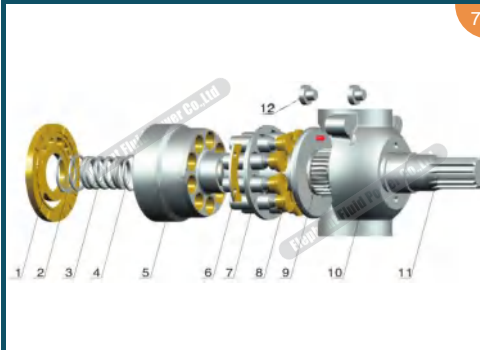

CAT215/245/992

NO. 序号	Description 部件名称	Quantity/Set 数量/台
1	Valve Plate (配油盘)	1
2	Snap Ring (卡环)	1
3	Coil Spring (大弹簧)	1
4	Washer (垫圈)	2
5	Cylinder Block (缸体)	1
6	Retainer (压板)	1
7	Retainer Plate (回程盘)	1
8	Piston Shoe (柱塞滑靴)	9
9	Thrust Plate (止推板)	1
10	Swash Plate (摇摆)	1
11	Drive Shaft (传动轴)	1
12	Locating Pin (定位销)	2

CAT/卡特系列

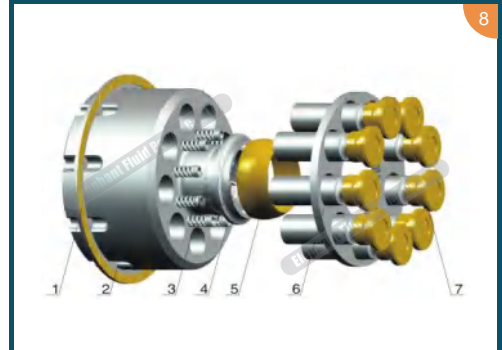

PSV450/PSV600

NO. 序号	Description 部件名称	Quantity/Set 数量/台
1	Friction Plate (摩擦片)	3
2	Cylinder Block (缸体)	1
3	Spring (弹簧)	9
4	Ball Guide Washer (球铰垫块)	1
5	Ball Guide (球铰)	1
6	Retainer Plate (回程盘)	1
7	Piston Shoe (柱塞滑靴)	9
8	Valve Plate (配油盘)	1

CAT/卡特系列

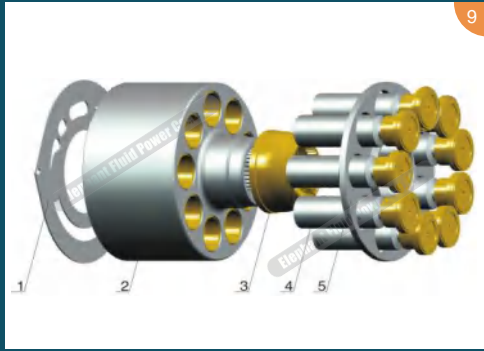

CAT385H

NO. 序号	Description 部件名称	Quantity/Set 数量/台
1	Valve Plate (配油盘)	1
2	Cylinder Block (缸体)	1
3	Ball Guide (球铰)	1
4	Piston Shoe (柱塞滑靴)	9
5	Retainer Plate (回程盘)	1

KAWASAKI/川崎系列

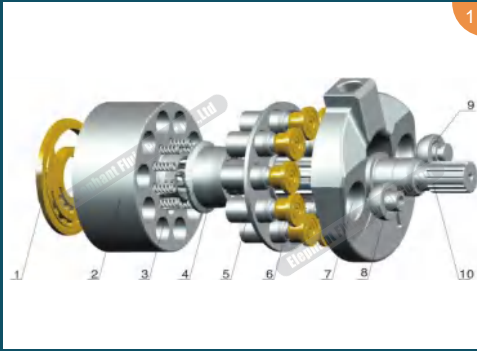

K3SP36C(SDV36)8T MAIN PUMP

NO. 序号	Description 部件名称	Quantity/Set 数量/台
1	Valve Plate (配油盘)	1
2	Cylinder Block (缸体)	1
3	Ball Guide Spring (球铰弹簧)	10
4	Ball Guide (球铰)	1
5	Retainer Plate (回程盘)	1
6	Piston Shoe (柱塞滑靴)	10
7	Swash Plate (摇摆)	1
8	Yoke Ball Left (摇摆球左)	1
9	Yoke Ball Right (摇摆球右)	1
10	Drive Shaft (传动轴)	1

KAWASAKI/川崎系列

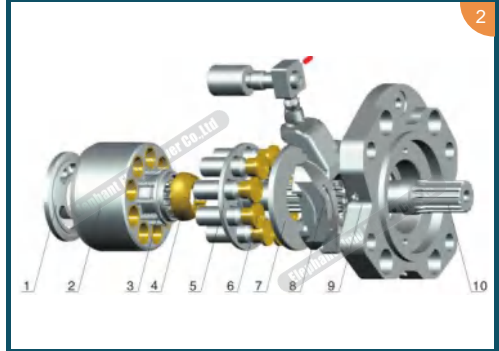

K3V63DT-180DT/280/G280/G180/K5V80-200

NO. 序号	Description 部件名称	Quantity/Set 数量/台
1	Valve Plate (配油盘)	2
2	Cylinder Block (缸体)	2
3	Washer (垫圈)	2
4	Ball Guide (球铰)	2
5	Retainer Plate (回程盘)	2
6	Piston Shoe (柱塞滑靴)	18
7	Thrust Plate (止推板)	2
8	Swash Plate (摇摆)	2
9	Support (摇摆座)	2
10	Drive Shaft Front/Rear (传动轴)	1

KAWASAKI/川崎系列

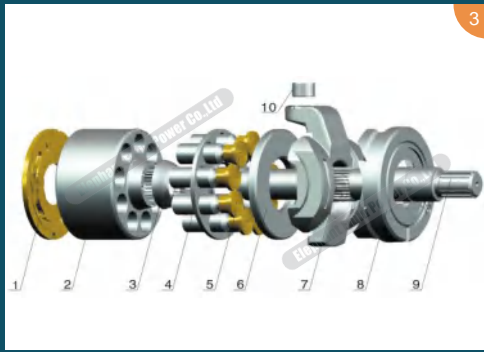

K3VL45/80

NO. 序号	Description 部件名称	Quantity/Set 数量/台
1	Valve Plate (配油盘)	1
2	Cylinder Block (缸体)	1
3	Ball Guide (球铰)	1
4	Retainer Plate (回程盘)	1
5	Piston Shoe (柱塞滑靴)	9
6	Thrust Plate (止推板)	1
7	Swash Plate (摇摆)	1
8	Support (摇摆座)	1
9	Drive Shaft (传动轴)	1
10	Swash Plate Sleeve (摇摆套)	1

KAWASAKI/川崎系列

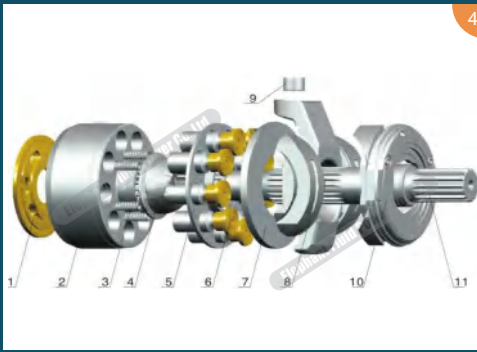

K7V63

NO. 序号	Description 部件名称	Quantity/Set 数量/台
1	Valve Plate (配油盘)	2
2	Cylinder Block (缸体)	2
3	Ball Guide Spring (球铰弹簧)	12
4	Ball Guide (球铰)	2
5	Retainer Plate (回程盘)	2
6	Piston Shoe (柱塞滑靴)	18
7	Thrust Plate (止推板)	2
8	Swash Plate (摇摆)	2
9	Swash Plate Sleeve (摇摆套)	2
10	Support (摇摆座)	2
11	Drive Shaft (传动轴)	2

KAWASAKI/川崎系列

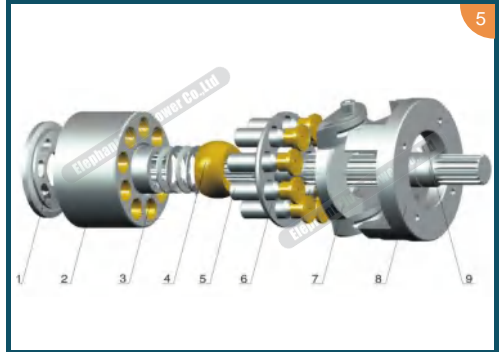

NV64/NV84/NV111DT/NV137/NV172/NV270

NO. 序号	Description 部件名称	Quantity/Set 数量/台
1	Valve Plate L/R (配油盘)	1
2	Cylinder Block (缸体)	2
3	Disc Spring (碟簧)	8
4	Ball Guide (球铰)	2
5	Piston Shoe (柱塞滑靴)	18
6	Retainer Plate (回程盘)	2
7	Swash Plate (摇摆)	2
8	Support (摇摆座)	2
9	Drive Shaft Front/Rear (传动轴)	1

大象流体动力

Elephant Fluid Power

KAWASAKI/川崎系列

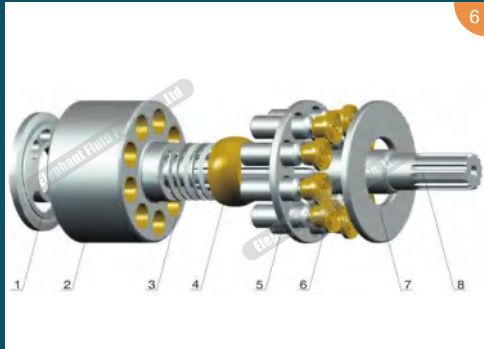

NX15

NO. 序号	Description 部件名称	Quantity/Set 数量/台
1	Valve Plate (配油盘)	1
2	Cylinder Block (缸体)	1
3	Disc Spring (碟簧)	4
4	Ball Guide (球铰)	1
5	Retainer Plate (回程盘)	1
6	Piston Shoe (柱塞滑靴)	9
7	Thrust Plate (止推板)	1
8	Drive Shaft (传动轴)	1

KAWASAKI/川崎系列

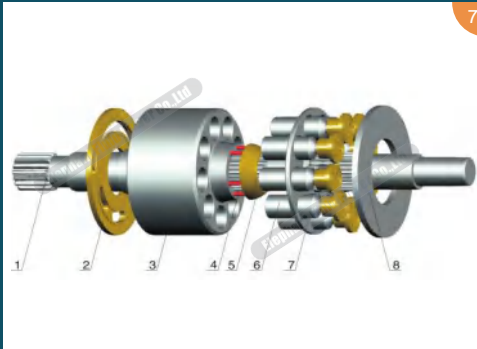

NVK45(KOBELCO EXCAVATOR)

NO. 序号	Description 部件名称	Quantity/Set 数量/台
1	Drive Shaft (传动轴)	2
2	Valve Plate (配油盘)	2
3	Cylinder Block (缸体)	2
4	Press Pin (顶针)	12
5	Ball Guide (球铰)	2
6	Piston Shoe (柱塞滑靴)	18
7	Retainer Plate (回程盘)	2
8	Thrust Plate (止推板)	2

KAWASAKI/川崎系列

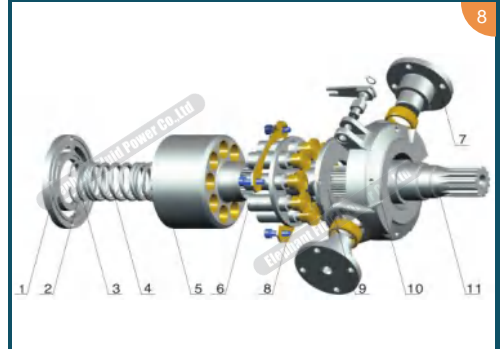

KVC925/KVC930/KVC932

NO. 序号	Description 部件名称	Quantity/Set 数量/台
1	Valve Plate (配油盘)	1
2	Snap Ring (卡环)	1
3	Washer (垫圈)	2
4	Spring (弹簧)	1
5	Cylinder Block (缸体)	1
6	Piston Shoe (柱塞滑靴)	9
7	Axial Shaft (传动轴)	2
8	Retainer Plate (回程盘)	1
9	Thrust Plate (止推板)	1
10	Swash Plate (摇摆)	1
11	Drive Shaft (传动轴)	1

KAWASAKI SWING/川崎回转系列

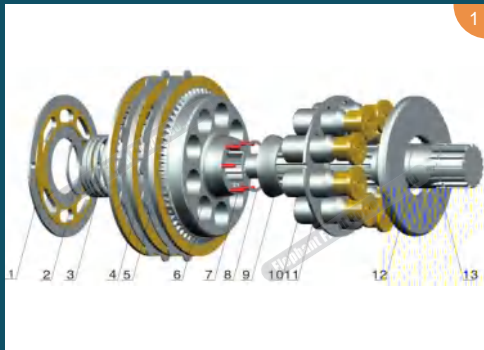

M2X63/96/120/146/150/170/210

NO. 序号	Description 部件名称	Quantity/Set 数量/台
1	Valve Plate (配油盘)	1
2	Washer (垫圈)	1
3	Coli Spring (大弹簧)	1
4	Friction Plate (摩擦片)	3
5	Seperation Plate (分隔片)	4
6	Cylinder Block (缸体)	1
7	Press Pin (顶针)	6
8	Washer (垫圈)	1
9	Ball Guide (球铰)	1
10	Piston Shoe (柱塞滑靴)	9
11	Retainer Plate (回程盘)	1
12	Thrust Plate (止推板)	1
13	Drive Shaft (传动轴)	1

KAWASAKI SWING/川崎回转系列

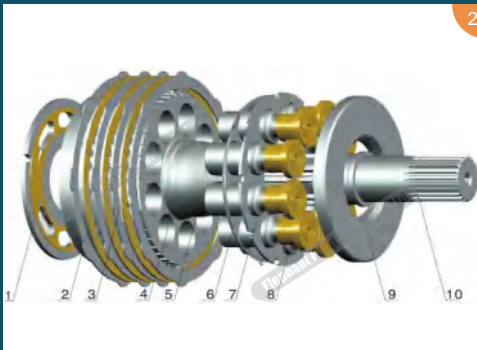

M5X130(CAT320C)/
M5X180(KOBELCO 350-8 SWING MOTOR)

NO. 序号	Description 部件名称	Quantity/Set 数量/台
1	Valve Plate M (配油盘)	1
2	Friction Plate (摩擦片)	3
3	Seperation Plate (分隔片)	4
4	Cylinder Block (缸体)	1
5	Ball Guide (球铰)	1
6	Retainer Plate (回程盘)	1
7	Retainer (压板)	1
8	Piston Shoe (柱塞滑靴)	9
9	Thrust Plate (止推板)	1
10	Drive Shaft (传动轴)	1

KAWASAKI SWING/川崎回转系列

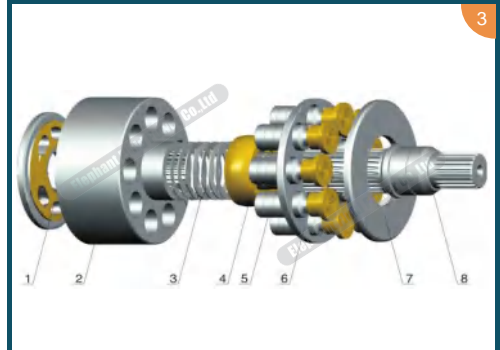

MX150/MX173/MX500

NO. 序号	Description 部件名称	Quantity/Set 数量/台
1	Valve Plate (配油盘)	1
2	Cylinder Block (缸体)	1
3	Disc Spring (碟簧)	1
4	Ball Guide (球铰)	1
5	Piston Shoe (柱塞滑靴)	9
6	Retainer Plate (回程盘)	1
7	Thrust Plate (止推板)	1
8	Drive Shaft (传动轴)	1

KAWASAKI SWING/川崎回转系列

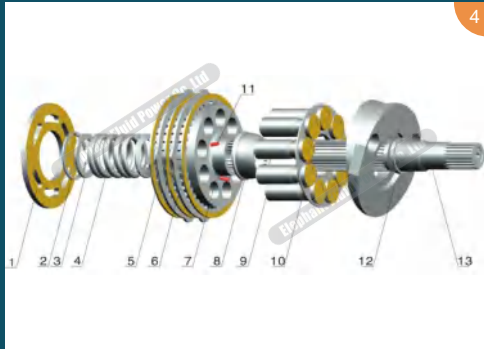

MAG150/170

NO. 序号	Description 部件名称	Quantity/Set 数量/台
1	Valve Plate (配油盘)	1
2	Snap Ring (卡环)	1
3	Washer (垫圈)	1
4	Coli Spring (大弹簧)	1
5	Friction Plate (摩擦片)	3
6	Seperation Plate (分隔片)	4
7	Cylinder Block (缸体)	1
8	Ball Guide (球铰)	1
9	Piston Shoe (柱塞滑靴)	9
10	Retainer Plate (回程盘)	1
11	Press Pin (顶针)	6
12	Swash Plate (摇摆)	1
13	Drive Shaft (传动轴)	1

KAWASAKI SWING/川崎回转系列

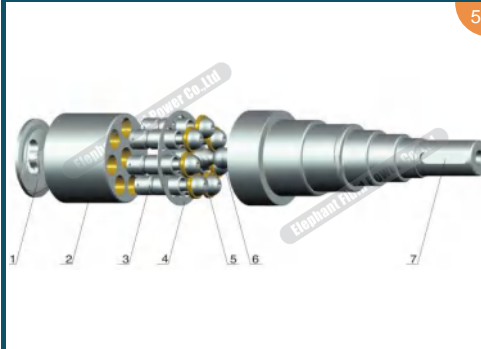

LZV30/120/LVWO60

NO. 序号	Description 部件名称	Quantity/Set 数量/台
1	Valve Plate (配油盘)	1
2	Cylinder Block (缸体)	1
3	Piston Shoe (柱塞滑靴)	7
4	Retainer Plate (回程盘)	1
5	Spherical Washer (球形垫圈)	7
6	Center Pin (中心柱塞)	1
7	Main Shaft (主轴)	1

KAWASAKI SWING/川崎回转系列

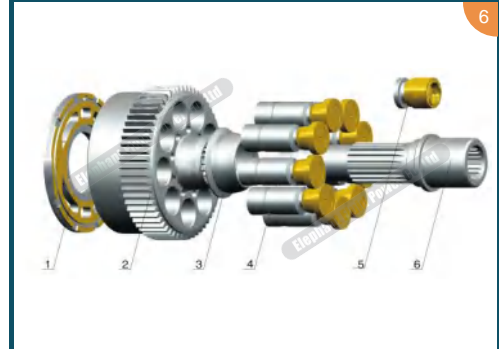

TM40VD TRAVEL MOTOR

NO. 序号	Description 部件名称	Quantity/Set 数量/台
1	Valve Plate M (配油盘)	1
2	Cylinder Block (缸体)	1
3	Ball Guide (球铰)	1
4	Piston Shoe (柱塞滑靴)	9
5	Yoke Piston (支撑柱塞)	1
6	Drive Shaft (传动轴)	1

LINDE/林德系列

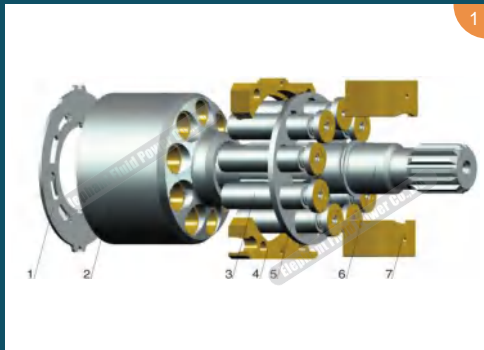

HPV55T(LINDE)/HPR75/100/105/130/LINDE
HMR135/HPR160

NO. 序号	Description 部件名称	Quantity/Set 数量/台
1	Valve Plate (配油盘)	1
2	Cylinder Block (缸体)	1
3	Piston Shoe (柱塞滑靴)	9
4	Retainer (压板)	2
5	Retainer Plate (回程盘)	1
6	Drive Shaft (传动轴)	1
7	Saddle Bearing (月牙轴承)	2
8	Swash Plate (摇摆)	1
9	Support (摇摆座)	1

LINDE/林德系列

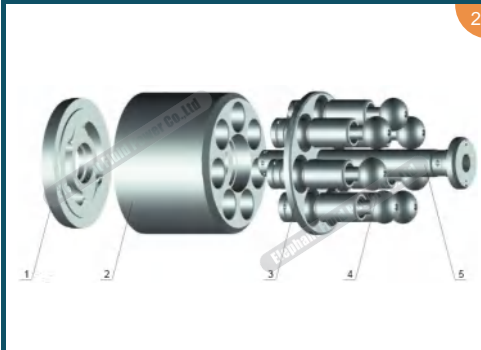

B2PV35~140

NO. 序号	Description 部件名称	Quantity/Set 数量/台
1	Valve Plate (配油盘)	1
2	Cylinder Block (缸体)	1
3	Retainer Plate (回程盘)	1
4	Piston Shoe (柱塞滑靴)	7
5	Center Pin (中心柱塞)	1
6	Ball Guide (球铰)	1

LINDE/林德系列

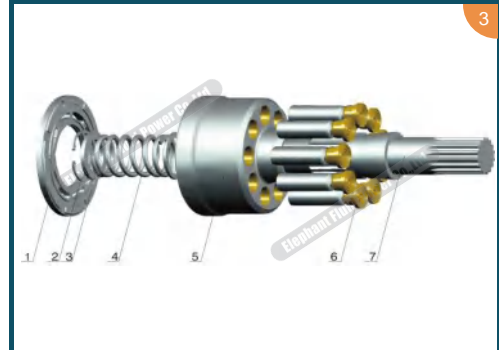

BPV35/BPV50/BPV70/BPV100

NO. 序号	Description 部件名称	Quantity/Set 数量/台
1	Valve Plate (配油盘)	1
2	Snap Ring (卡环)	1
3	Washer (垫圈)	2
4	Spring (弹簧)	1
5	Cylinder Block (缸体)	1
6	Piston Shoe (柱塞滑靴)	9
7	Main Shaft (主轴)	1

大象流体动力

Elephant Fluid Power

LINDE/林德系列

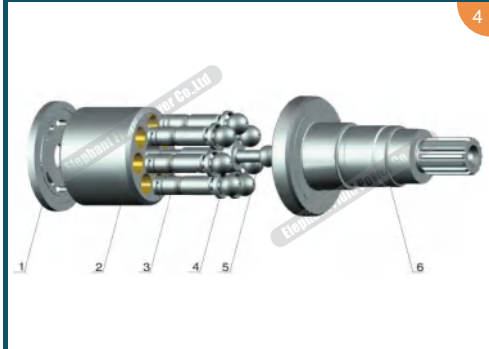

BMV75.27

NO. 序号	Description 部件名称	Quantity/Set 数量/台
1	Valve Plate (配油盘)	1
2	Cylinder Block (缸体)	1
3	Piston Shoe (柱塞滑靴)	7
4	Spherical Washer (球形垫圈)	7
5	Center Pin (中心柱塞)	1
6	Drive Shaft (传动轴)	1

LINDE/林德系列

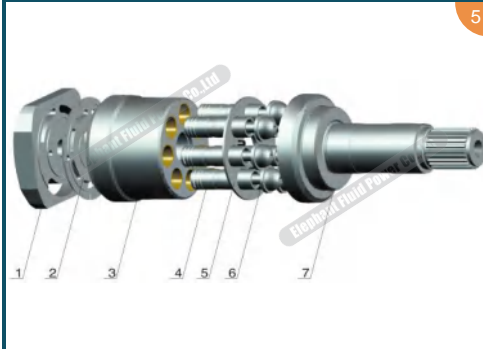

BPR140/186/260

NO. 序号	Description 部件名称	Quantity/Set 数量/台
1	Swash Plate (摇摆)	1
2	Valve Plate M (配油盘)	1
3	Cylinder Block (缸体)	1
4	Piston Shoe (柱塞滑靴)	7
5	Retainer Plate (回程盘)	1
6	Spherical Washer (球形垫圈)	7
7	Drive Shaft (传动轴)	1

LINDE/林德系列

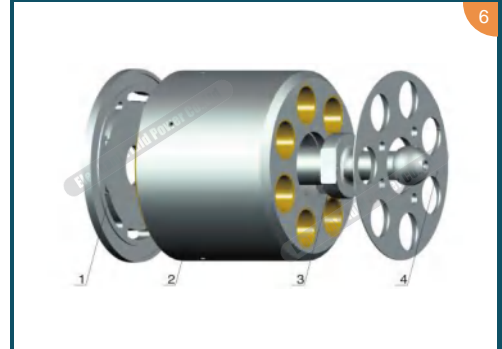

BMF50/75/105

NO. 序号	Description 部件名称	Quantity/Set 数量/台
1	Valve Plate (配油盘)	1
2	Cylinder Block (缸体)	1
3	Center Pin (中心柱塞)	1
4	Retainer Plate (回程盘)	1

EATON/伊顿系列

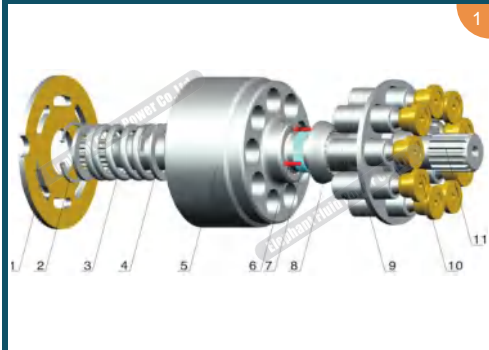

EATON 006/3322/3932-243/4621/4631-007/5421/5431/6423/7621/78462/CASE1460

NO. 序号	Description 部件名称	Quantity/Set 数量/台
1	Valve Plate L/R/M (配油盘)	1
2	Snap Ring (卡环)	1
3	Spring (弹簧)	2
4	Washer (垫圈)	1
5	Cylinder Block (缸体)	1
6	Press Pin (顶针)	3
7	Back-UP Ring (卡簧)	2
8	Ball Guide (球铰)	1
9	Retainer Plate (回程盘)	1
10	Piston Shoe (柱塞滑靴)	9
11	Drive Shaft (传动轴)	1
12	Shaft Seal Kits (轴封)	1
13	Shaft Seal Kits (轴封)	1

EATON-VICKERS/伊顿 威格士系列

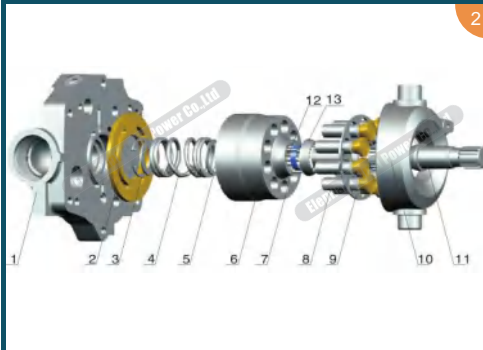

PVE19/PVE21/TA19

NO. 序号	Description 部件名称	Quantity/Set 数量/台
1	Rear Cover (后盖)	1
2	Valve Plate L/R (配油盘)	1
3	Snap Ring (卡环)	1
4	Spring (弹簧)	1
5	Washer (垫圈)	2
6	Cylinder Block (缸体)	1
7	Back-UP Ring (卡簧)	1
8	Piston Shoe (柱塞滑靴)	9
9	Retainer Plate (回程盘)	1
10	Swash Plate (摇摆)	1
11	Drive Shaft (传动轴)	1
12	Press Pin (顶针)	1
13	Ball Guide (球铰)	1

EATON-VICKERS/伊顿 威格士系列

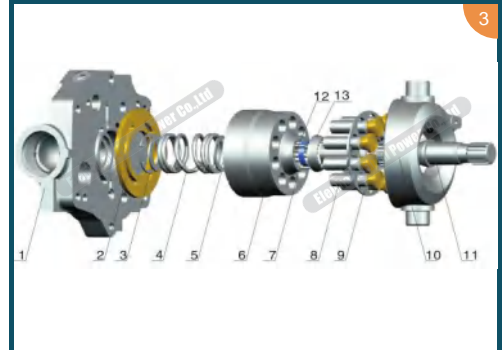

PVH45-141

NO. 序号	Description 部件名称	Quantity/Set 数量/台
1	Valve Plate M (配油盘)	1
2	Snap Ring (卡环)	1
3	Spring (弹簧)	1
4	Washer (垫圈)	2
5	Counter Piston Assy (垫片)	1
6	Cylinder Block (缸体)	1
7	Bolt (螺钉)	4
8	Retainer (压板)	2
9	Retainer Plate (回程盘)	2
10	Piston Shoe (柱塞滑靴)	18
11	Spacer (垫块)	2
12	Saddle Bearing (轴瓦)	2
13	Drive Shaft (传动轴)	1
14	Valve (控制阀)	1
15	Swash Plate (摇摆)	1

EATON-VICKERS/伊顿 威格士系列

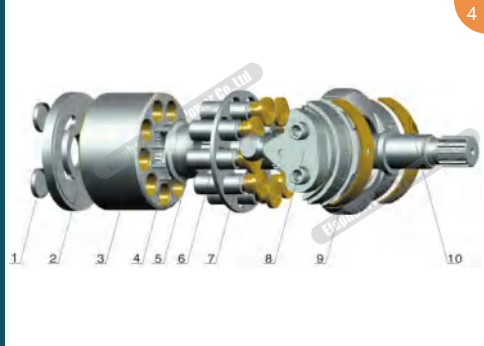

PVB5/PVB6/PVB10/PVB15/PVB20/
PVB29/PVBQA29-SR/PVB110

NO. 序号	Description 部件名称	Quantity/Set 数量/台
1	Rear Cover (后盖)	1
2	Valve Plate (配油盘)	1
3	Cylinder Block (缸体)	1
4	Spring (弹簧)	1
5	Ball Guide (球铰)	1
6	Piston Shoe (柱塞滑靴)	9
7	Retainer Plate (回程盘)	1
8	Swash Plate (摇摆)	1
9	Saddle Bearing (轴瓦)	2
10	Drive Shaft (传动轴)	1
11	Thrust Plate (止推板)	1
12	Valve (控制阀)	1

EATON-VICKERS/伊顿 威格士系列

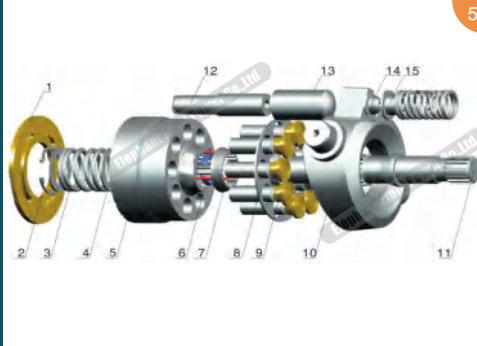

PVQ40/50

NO. 序号	Description 部件名称	Quantity/Set 数量/台
1	Valve Plate M (配油盘)	1
2	Snap Ring (卡环)	1
3	Spring (弹簧)	1
4	Washer (垫圈)	1
5	Cylinder Block (缸体)	1
6	Back-UP Ring (卡簧)	1
7	Ball Guide (球铰)	1
8	Retainer Plate (回程盘)	1
9	Piston Shoe (柱塞滑靴)	9
10	Swash Plate (摇摆)	1
11	Drive Shaft (传动轴)	1
12	Servo Piston Rod (伺服活塞杆)	1
13	Servo Piston Guide (伺服活塞套)	1
14	Yoke Ball (支撑球)	1
15	Ball Support (球面支座)	1

VICKERS/威格士系列

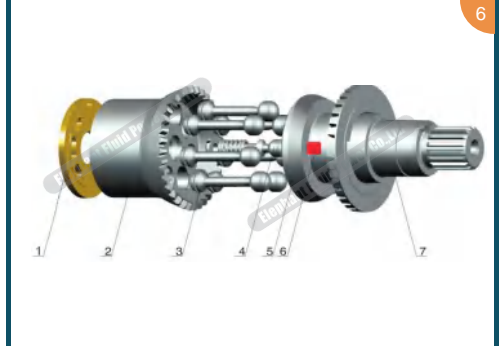

VOLVO/F11-005-250/F12-060/080/110-MF-1H

NO. 序号	Description 部件名称	Quantity/Set 数量/台
1	Valve Plate (配油盘)	1
2	Cylinder Block (缸体)	1
3	Piston Shoe (柱塞滑靴)	5
4	Center Pin (中心柱塞)	1
5	Drive Shaft (传动轴)	1
6	Drive Shaft Key (传动轴)	1
7	Driven Shaft (从动轴)	1

VICKERS/威格士系列

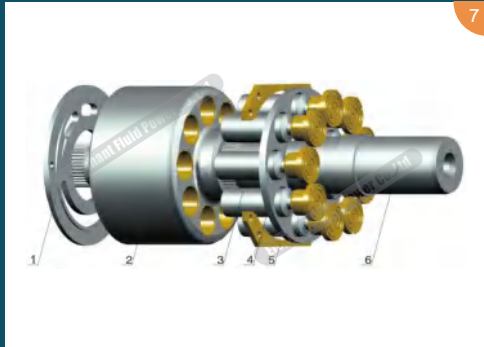

PVSO250

NO. 序号	Description 部件名称	Quantity/Set 数量/台
1	Valve Plate (配油盘)	1
2	Cylinder Block (缸体)	1
3	Piston Shoe (柱塞滑靴)	9
4	Retainer Plate (回程盘)	1
5	Retainer (压板)	2
6	Drive Shaft (传动轴)	1
7	Retainer (压板)	1
8	Saddle Bearing (轴瓦)	2

VICKERS/威格士系列

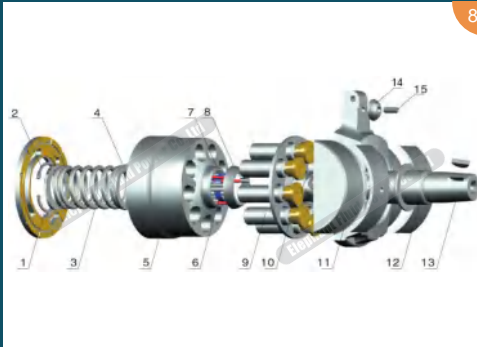

PVM-018/PVM-028

NO. 序号	Description 部件名称	Quantity/Set 数量/台
1	Valve Plate M (配油盘)	1
2	Snap Ring (卡环)	1
3	Spring (弹簧)	1
4	Washer (垫圈)	2
5	Cylinder Block (缸体)	1
6	Back-UP Ring (卡簧)	1
7	Press Pin (顶针)	3
8	Ball Guide (球铰)	1
9	Piston Shoe (柱塞滑靴)	9
10	Retainer Plate (回程盘)	1
11	Swash Plate (摇摆)	1
12	Saddle Bearing (轴瓦)	2
13	Center Pin (中心柱塞)	1
14	Yoke Ball (支撑球)	1
15	Ball Support (球面支座)	1

VICKERS/威格士系列

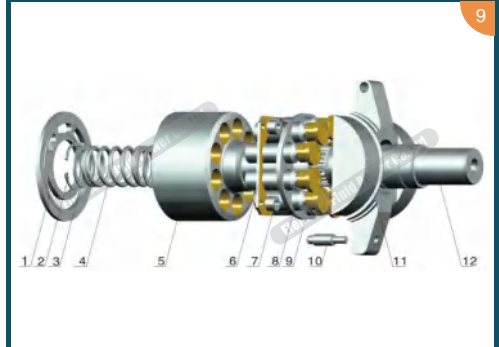

BMHQ30/PV180 PARKER

NO. 序号	Description 部件名称	Quantity/Set 数量/台
1	Valve Plate (配油盘)	1
2	Snap Ring (卡环)	1
3	Coil Spring (大弹簧)	1
4	Washer (垫圈)	2
5	Cylinder Block (缸体)	1
6	Retainer (压板)	1
7	Spacer (垫块)	1
8	Piston Shoe (柱塞滑靴)	9
9	Retainer Plate (回程盘)	1
10	Locating Pin (定位销)	1
11	Swash Plate (摇摆)	1
12	Drive Shaft (传动轴)	2

大象流体动力

Elephant Fluid Power

VICKERS/威格士系列

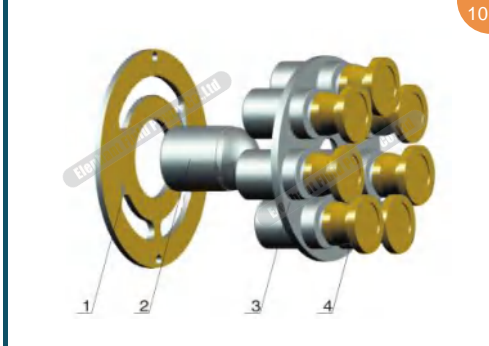

PAVC38/PAVC65/PAVC100 PARKER

NO. 序号	Description 部件名称	Quantity/Set 数量/台
1	Valve Plate (配油盘)	1
2	Cylinder Block (缸体)	1
3	Retainer Plate (回程盘)	1
4	Piston Shoe (柱塞滑靴)	7

VICKERS/威格士系列

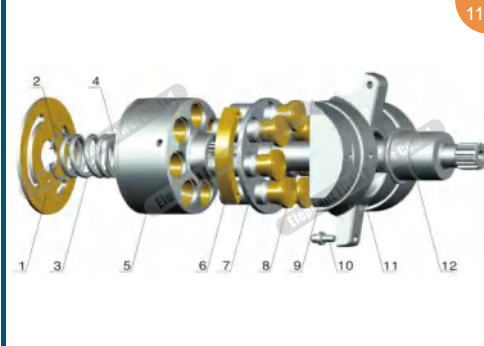

PARKER 2145/P2145 PARKER 23/P2075/PARKER 270/PV270/P2105/P2060

NO. 序号	Description 部件名称	Quantity/Set 数量/台
1	Valve Plate (配油盘)	1
2	Snap Ring (卡环)	1
3	Spring (大弹簧)	1
4	Washer (垫圈)	2
5	Cylinder Block (缸体)	1
6	Retainer (压板)	2
7	Retainer Plate (回程盘)	1
8	Piston Shoe (柱塞滑靴)	9
9	Swash Plate (摇摆)	1
10	Yoke Piston (支撑柱塞)	1
11	Saddle Bearing (轴瓦)	2
12	Drive Shaft (传动轴)	1

VICKERS/威格士系列

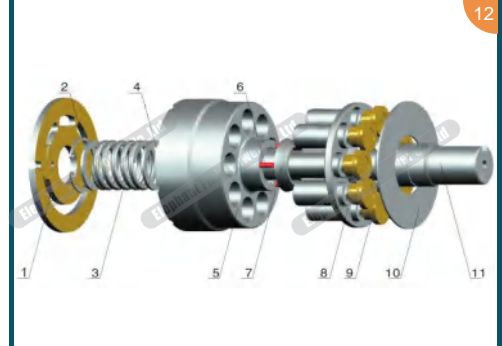

PV29/PV74

NO. 序号	Description 部件名称	Quantity/Set 数量/台
1	Valve Plate (配油盘)	1
2	Snap Ring (卡环)	1
3	Washer (垫圈)	1
4	Spring (弹簧)	2
5	Cylinder Block (缸体)	1
6	Press Pin (顶针)	3
7	Ball Guide (球铰)	1
8	Retainer Plate (回程盘)	1
9	Piston Shoe (柱塞滑靴)	9
10	Thrust Plate (止推板)	1
11	Drive Shaft (传动轴)	1

VICKERS/威格士系列

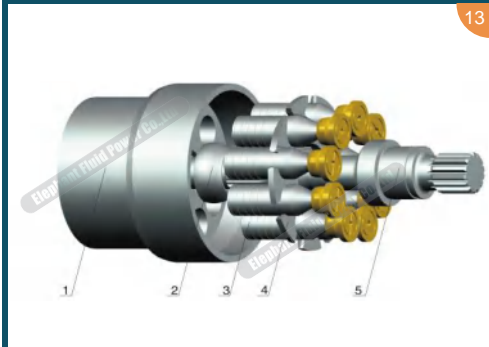

PVG130 B

NO. 序号	Description 部件名称	Quantity/Set 数量/台
1	Cylinder Block (缸体)	1
2	Ball Guide (球铰)	1
3	Piston Shoe (柱塞滑靴)	9
4	Retainer Plate (回程盘)	1
5	Drive Shaft (传动轴)	1

VICKERS/威格士系列

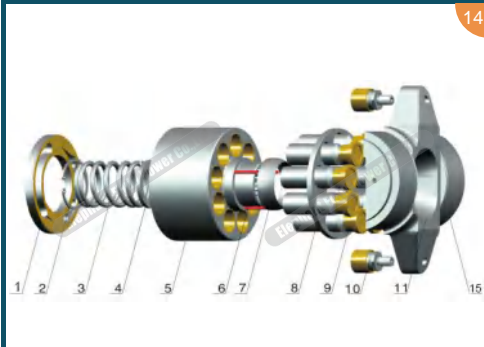

PVT38/PVT64

NO. 序号	Description 部件名称	Quantity/Set 数量/台
1	Valve Plate (配油盘)	1
2	Snap Ring (卡环)	1
3	Coil Spring (大弹簧)	1
4	Washer (垫圈)	2
5	Cylinder Block (缸体)	1
6	Press Pin (顶针)	1
7	Ball Guide (球铰)	1
8	Retainer Plate (回程盘)	9
9	Piston Shoe (柱塞滑靴)	1
10	Servo Piston (伺服活塞)	1
11	Swash Plate (摇摆)	1
12	Saddle Bearing (轴瓦)	2

VICKERS/威格士系列

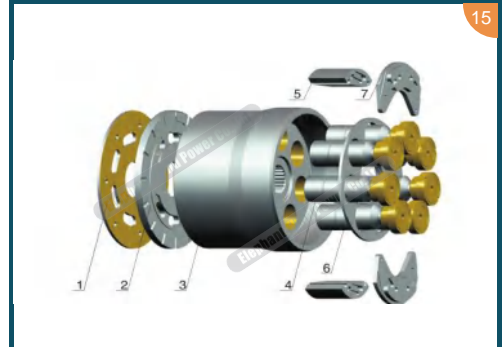

SH5V/131

NO. 序号	Description 部件名称	Quantity/Set 数量/台
1	Bearing Plate (衬板)	1
2	Valve Plate (配油盘)	1
3	Cylinder Block (缸体)	1
4	Piston Shoe (柱塞滑靴)	9
5	Retainer (压板)	1
6	Retainer Plate (回程盘)	1
7	Retainer 1 (压板)	2
8	Retainer 2 (压板)	2

NACHI/不二越系列

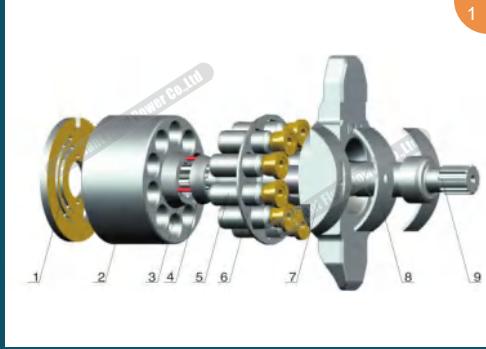

PVD-2B-32L/34L/36L/38/40/42/63

NO. 序号	Description 部件名称	Quantity/Set 数量/台
1	Valve Plate (配油盘)	1
2	Cylinder Block (缸体)	1
3	Press Pin (顶针)	3
4	Ball Guide (球铰)	1
5	Piston Shoe (柱塞滑靴)	2
6	Retainer Plate (回程盘)	1
7	Swash Plate (摇摆)	1
8	Saddle Bearing (轴瓦)	2
9	Drive Shaft (传动轴)	1

NACHI/不二越系列

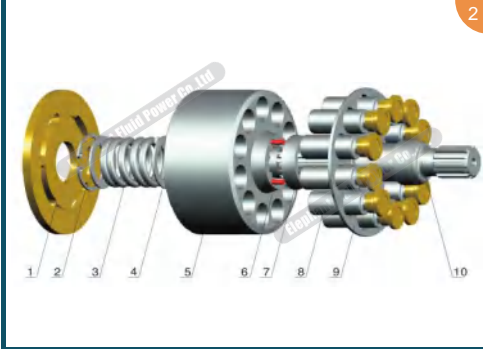

PVK-2B-505(ZAX55 MAIN PUMP)

NO. 序号	Description 部件名称	Quantity/Set 数量/台
1	Valve Plate (配油盘)	1
2	Snap Ring (卡环)	1
3	Spring (大弹簧)	1
4	Washer (垫圈)	2
5	Cylinder Block (缸体)	1
6	Press Pin (顶针)	3
7	Ball Guide (球铰)	1
8	Piston Shoe (柱塞滑靴)	11
9	Retainer Plate (回程盘)	1
10	Drive Shaft (传动轴)	1

NACHI/不二越系列

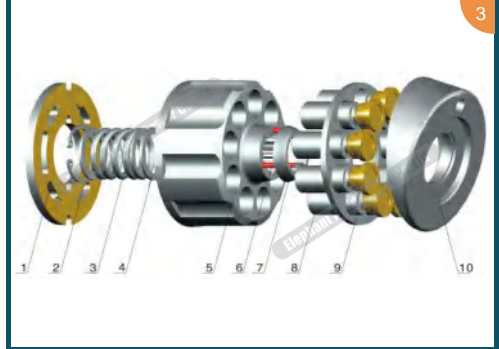

YC35-6/PCL-200-18B(YUCHA 55 SWING MOTORT)

NO. 序号	Description 部件名称	Quantity/Set 数量/台
1	Valve Plate (配油盘)	1
2	Snap Ring (卡环)	1
3	Spring (弹簧)	1
4	Washer (垫圈)	2
5	Cylinder Block (缸体)	1
6	Press Pin (顶针)	3
7	Ball Guide (球铰)	1
8	Piston Shoe (柱塞滑靴)	9
9	Retainer Plate (回程盘)	1
10	Swash Plate (摇摆)	1

TOSHIBA/东芝系列

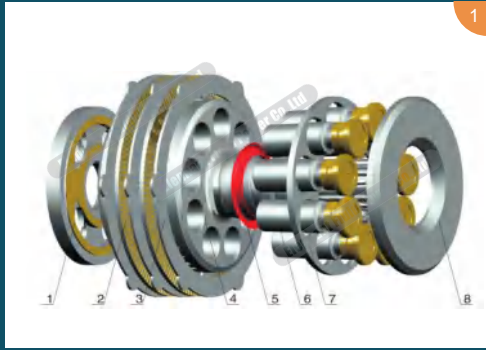

SG02/025/04/08/12/20

NO. 序号	Description 部件名称	Quantity/Set 数量/台
1	Valve Plate (配油盘)	1
2	Friction Plate (摩擦片)	2
3	Seperation Plate (分隔片)	3
4	Cylinder Block (缸体)	1
5	Washer (垫片)	1
6	Piston Shoe (柱塞滑靴)	9
7	Retainer Plate (回程盘)	1
8	Thrust Plate (止推板)	1

TOSHIBA/东芝系列

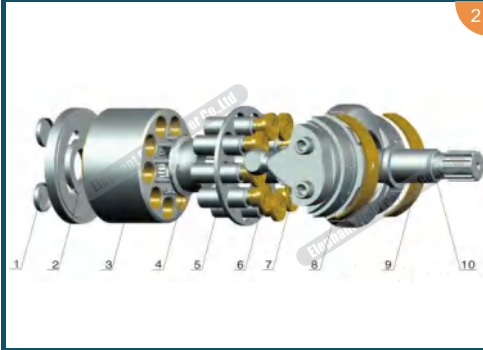

PVB92

NO. 序号	Description 部件名称	Quantity/Set 数量/台
1	Nut (垫块)	2
2	Valve Plate (配油盘)	1
3	Cylinder Block (缸体)	1
4	Ball Guide (球铰)	1
5	Retainer Plate (回程盘)	1
6	Piston Shoe (柱塞滑靴)	9
7	Servo Block (反向阀芯阀杆)	1
8	Swash Plate (摇摆)	1
9	Saddle Bearing (轴瓦)	2
10	Drive Shaft (传动轴)	1

TOSHIBA/东芝系列

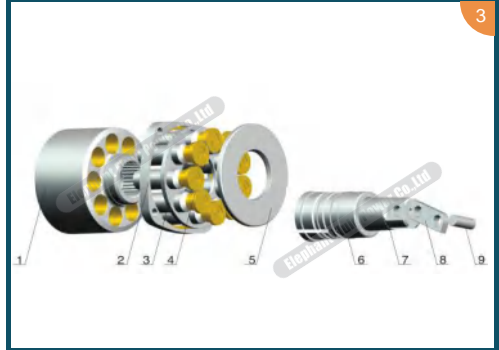

PV090/PV092

NO. 序号	Description 部件名称	Quantity/Set 数量/台
1	Cylinder Block (缸体)	1
2	Retainer (压板)	1
3	Retainer Plate (回程盘)	1
4	Piston Shoe (柱塞滑靴)	9
5	Thrust Plate (止推板)	1
6	Servo Piston Guide (伺服柱塞套)	1
7	Servo Piston (伺服柱塞)	1
8	Block (锁块)	1
9	Pin (顶针)	1

大象流体动力

Elephant Fluid Power

TOSHIBA/东芝系列

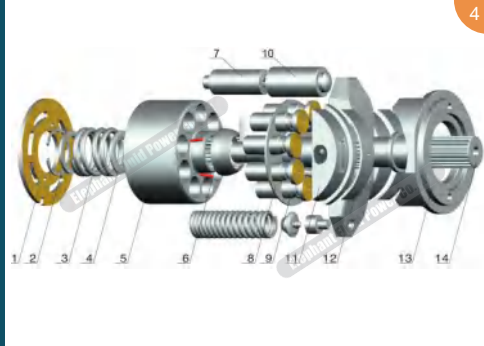

PSVD SERIES

NO. 序号	Description 部件名称	Quantity/Set 数量/台
1	Valve Plate L/R (配油盘)	1
2	Snap Ring (卡环)	1
3	Coli Spring (大弹簧)	1
4	Washer (垫圈)	2
5	Cylinder Block (缸体)	1
6	Ball Guide (球铰)	1
7	Control Piston (控制活塞)	1
8	Retainer Plate (回程盘)	1
9	Piston Shoe (柱塞滑靴)	9
10	Control Piston Guide (控制活塞杆)	1
11	Swash Plate (摇摆)	1
12	Saddle Bearing (轴瓦)	2
13	Support (摇摆座)	1
14	Drive Shaft (传动轴)	1

YUKEN/油研系列

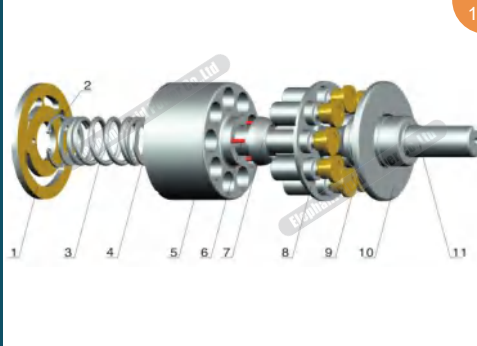

A16/A22/A37/A45/A56/A70/A90/A145

NO. 序号	Description 部件名称	Quantity/Set 数量/台
1	Valve Plate (配油盘)	1
2	Snap Ring (卡环)	1
3	Washer (垫圈)	2
4	Spring (弹簧)	1
5	Cylinder Block (缸体)	1
6	Press Pin (顶针)	3
7	Ball Guide (球铰)	1
8	Piston Shoe (柱塞滑靴)	9
9	Retainer Plate (回程盘)	1
10	Thrust Plate (止推板)	1
11	Drive Shaft (传动轴)	1

LIEBHERR/利勃海尔系列

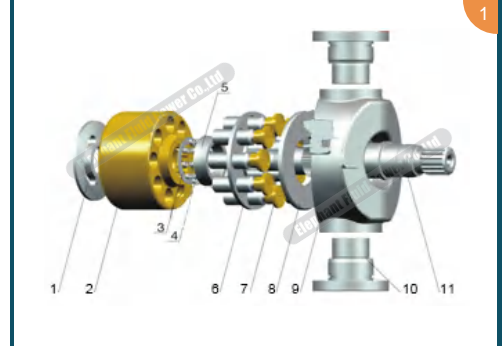

LPVD45~260

NO. 序号	Description 部件名称	Quantity/Set 数量/台
1	Valve Plate (配油盘)	1
2	Cylinder Block (缸体)	1
3	Snap Ring (卡环)	1
4	Coli Spring (大弹簧)	9
5	Ball Guide (球铰)	1
6	Retainer Plate (回程盘)	1
7	Piston Shoe (柱塞滑靴)	9
8	Thrust Plate (止推板)	1
9	Swash Plate (摇摆)	1
10	Bearing Seat (轴承座)	4
11	Drive Shaft (传动轴)	1

KAYABA/卡亚巴系列

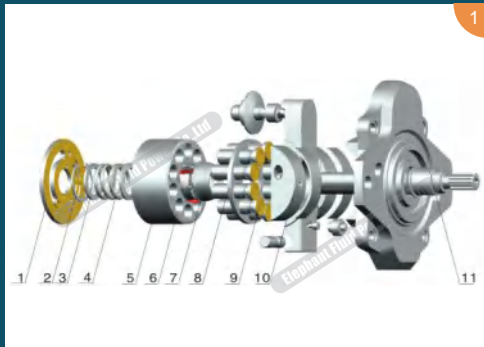

PSVD2-16E/21E/26E/27E/PSVD2-21/SVD22/PSVL-54

NO. 序号	Description 部件名称	Quantity/Set 数量/台
1	Valve Plate (配油盘)	1
2	Snap Ring (卡环)	1
3	Washer (垫圈)	2
4	Spring (弹簧)	1
5	Cylinder Block (缸体)	1
6	Press Pin (顶针)	3
7	Ball Guide (球铰)	1
8	Retainer Plate (回程盘)	1
9	Piston Shoe (柱塞滑靴)	10
10	Swash Plate (摇摆)	1
11	Drive Shaft (传动轴)	1
12	Charge Pump (补油泵)	1

KAYABA/卡亚巴系列

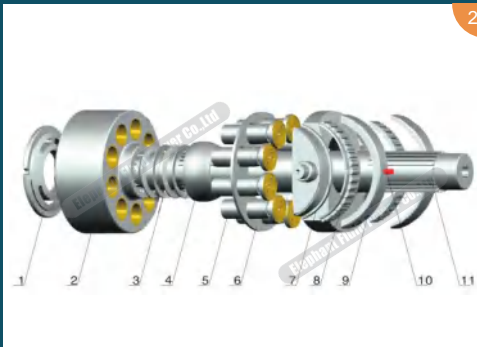

PSV2-55T(KYB)SUMITOMO 120

NO. 序号	Description 部件名称	Quantity/Set 数量/台
1	Valve Plate (配油盘)	1
2	Cylinder Block (缸体)	1
3	Disc Spring (碟簧)	1
4	Ball Guide (球铰)	1
5	Piston Shoe (柱塞滑靴)	9
6	Retainer Plate (回程盘)	1
7	Swash Plate (摇摆)	1
8	Saddle Bearing (轴承)	2
9	Saddle Bearing (轴承)	2
10	Locating Pin (定位销)	2
11	Drive Shaft (传动轴)	1
12	Charge Pump (补油泵)	1

KAYABA/卡亚巴系列

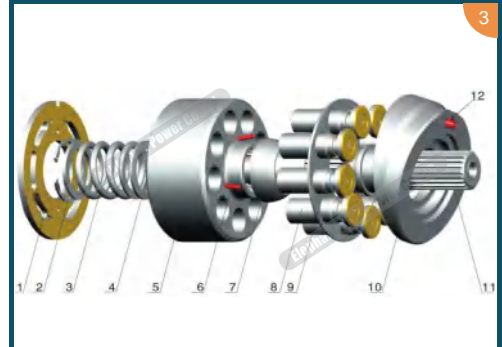

MSF-85/GMY18

NO. 序号	Description 部件名称	Quantity/Set 数量/台
1	Valve Plate M (配油盘)	1
2	Snap Ring (卡环)	1
3	Coli Spring (弹簧)	1
4	Washer (垫圈)	2
5	Cylinder Block (缸体)	1
6	Press Pin (顶针)	3
7	Ball Guide (球铰)	1
8	Piston Shoe (柱塞滑靴)	9
9	Retainer Plate (回程盘)	1
10	Swash Plate (摇摆)	1
11	Drive Shaft (传动轴)	1
12	Pin (顶针)	1

KAYABA/卡亚巴系列

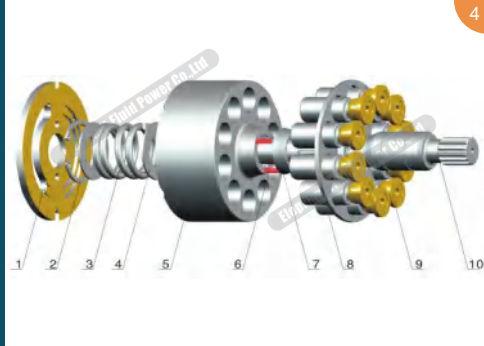

KYB-25CC/HISCE 60/PSVK2-25

NO. 序号	Description 部件名称	Quantity/Set 数量/台
1	Valve Plate (配油盘)	1
2	Snap Ring (卡环)	1
3	Coli Spring (大弹簧)	1
4	Washer (垫圈)	2
5	Cylinder Block (缸体)	1
6	Press Pin (顶针)	3
7	Ball Guide (球铰)	1
8	Retainer Plate (回程盘)	1
9	Piston Shoe (柱塞滑靴)	9
10	Drive Shaft (传动轴)	1

KAYABA/卡亚巴系列

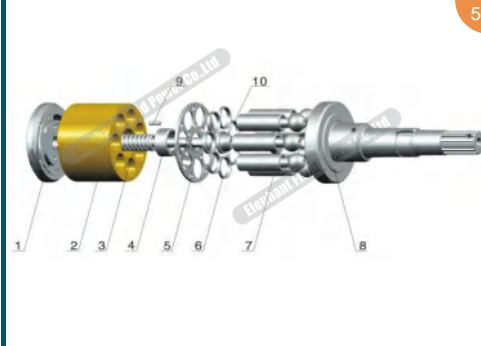

KMF40/40-2/90/KMF105

NO. 序号	Description 部件名称	Quantity/Set 数量/台
1	Valve Plate (配油盘)	1
2	Cylinder Block (缸体)	1
3	Coli Spring (大弹簧)	1
4	Sleeve (套筒)	1
5	Retainer Plate (回程盘)	1
6	Spherical Washer (球形垫圈)	7
7	Piston Shoe (柱塞滑靴)	7
8	Drive Shaft (传动轴)	1

KAYABA/卡亚巴系列

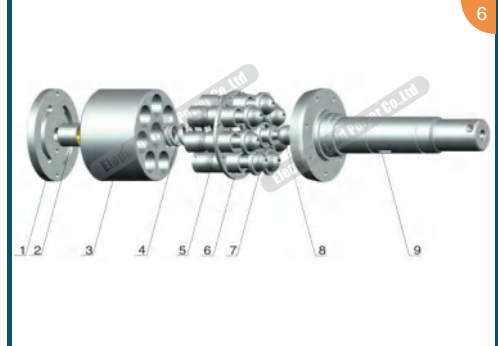

KYB33/KYB36/KYB87/KYB90(MSG-60P)

NO. 序号	Description 部件名称	Quantity/Set 数量/台
1	Valve Plate (配油盘)	1
2	Sleeve (套筒)	1
3	Cylinder Block (缸体)	1
4	Coli Spring (大弹簧)	1
5	Piston Shoe (柱塞滑靴)	7
6	Retainer Plate (回程盘)	1
7	Spherical Washer (球形垫圈)	7
8	Center Pin (中心柱塞)	1
9	Drive Shaft (传动轴)	1

KAYABA/卡亚巴系列

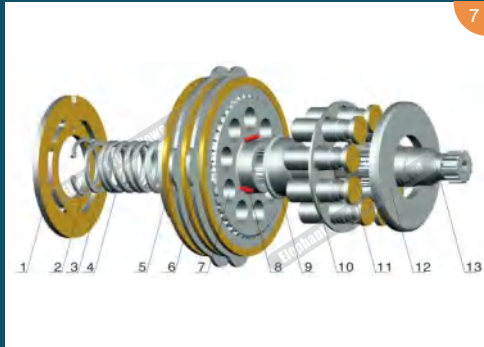

MSG-27P(KYB)/(LSGMF27/10W)/MSG-44P(KYB)/LSGMF44/10W-R21

NO. 序号	Description 部件名称	Quantity/Set 数量/台
1	Valve Plate (配油盘)	1
2	Snap Ring (卡环)	1
3	Washer (垫圈)	2
4	Spring (弹簧)	1
5	Friction Plate (摩擦片)	3
6	Seperation Plate (分隔片)	2
7	Cylinder Block (缸体)	1
8	Press Pin (顶针)	3
9	Ball Guide (球铰)	1
10	Retainer Plate (回程盘)	1
11	Piston Shoe (柱塞滑靴)	9
12	Thrust Plate (止推板)	1
13	Drive Shaft (传动轴)	1

KAYABA/卡亚巴系列

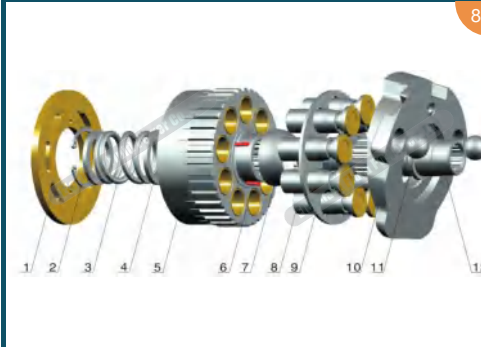

MAG-33VP-480E-2(4-5.5T TRAVEL MOTORT)

NO. 序号	Description 部件名称	Quantity/Set 数量/台
1	Valve Plate (配油盘)	1
2	Snap Ring (卡环)	1
3	Spring (弹簧)	1
4	Washer (垫圈)	2
5	Cylinder Block (缸体)	1
6	Press Pin (顶针)	3
7	Ball Guide (球铰)	1
8	Piston Shoe (柱塞滑靴)	9
9	Retainer Plate (回程盘)	1
10	Swash Plate (摇摆)	1
11	Press Ball (阀芯阀杆)	2
12	Drive Shaft (传动轴)	1

KAYABA/卡亚巴系列

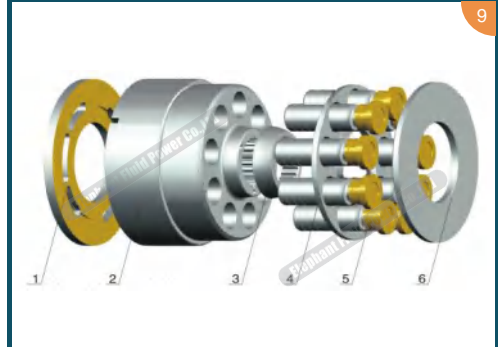

V25

NO. 序号	Description 部件名称	Quantity/Set 数量/台
1	Valve Plate (配油盘)	1
2	Cylinder Block (缸体)	1
3	Ball Guide (球铰)	1
4	Retainer Plate (回程盘)	1
5	Piston Shoe (柱塞滑靴)	7
6	Thrust Plate (止推板)	1

大象流体动力

Elephant Fluid Power

HAWE/哈威系列

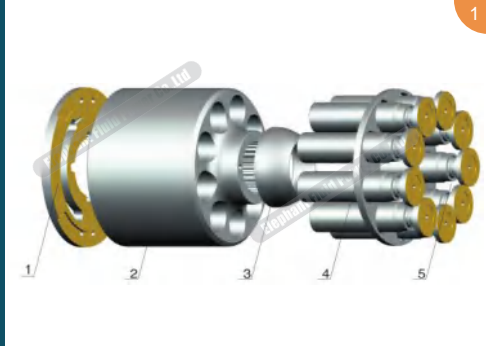

HAWA V60A

NO. 序号	Description 部件名称	Quantity/Set 数量/台
1	Valve Plate (配油盘)	1
2	Cylinder Block (缸体)	1
3	Ball Guide (球铰)	1
4	Retainer Plate (回程盘)	1
5	Piston Shoe (柱塞滑靴)	9

HAWE/哈威系列

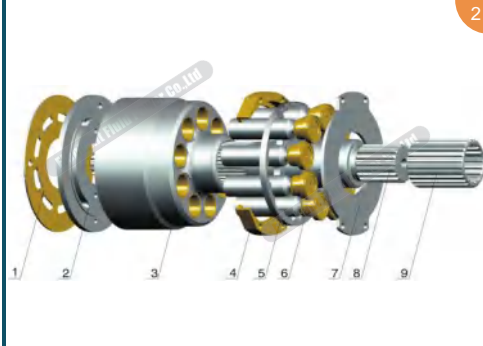

V30D45/V30D95/V30Z95/V30D140/V30D250

NO. 序号	Description 部件名称	Quantity/Set 数量/台
1	Bearing Plate (衬板)	1
2	Valve Plate (配油盘)	1
3	Cylinder Block (缸体)	1
4	Retainer (压板)	1
5	Retainer Plate (回程盘)	1
6	Piston Shoe (柱塞滑靴)	9
7	Thrust Plate (止推板)	1
8	Drive Shaft (传动轴)	1

TOKIWA/极东泵

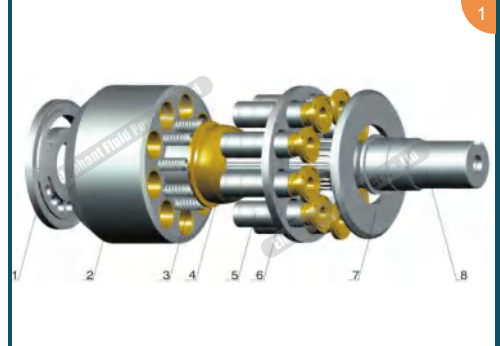

MKV23/MKV33

NO. 序号	Description 部件名称	Quantity/Set 数量/台
1	Valve Plate L/R (配油盘)	1
2	Cylinder Block (缸体)	1
3	Coli Spring (弹簧)	9
4	Ball Guide (球铰)	1
5	Piston Shoe (柱塞滑靴)	9
6	Retainer Plate (回程盘)	1
7	Thrust Plate (止推板)	1
8	Drive Shaft (传动轴)	1

JIC SERIES

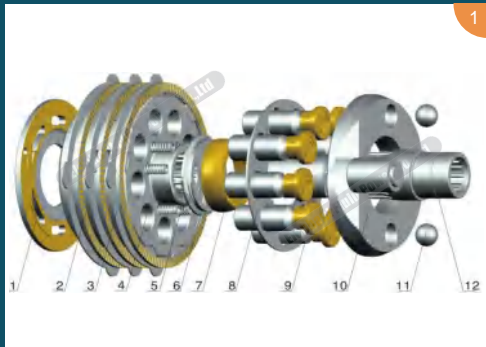

YC35-6/PCL-200-18B(YUCHAI 55 SWING MOTOR)

NO. 序号	Description 部件名称	Quantity/Set 数量/台
1	Valve Plate L/R/M (配油盘)	1
2	Friction Plate (摩擦片)	3
3	Seperation Plate (分隔片)	3
4	Cylinder Block (缸体)	1
5	Ball Guide Spring (球铰弹簧)	6
6	Ball Guide Washer (球铰垫块)	1
7	Ball Guide (球铰)	1
8	Retainer Plate (回程盘)	1
9	Piston Shoe (柱塞滑靴)	9
10	Swash Plate (摇摆)	1
11	Servo Ball (伺服球体)	2
12	Drive Shaft (传动轴)	1

JIC SERIES

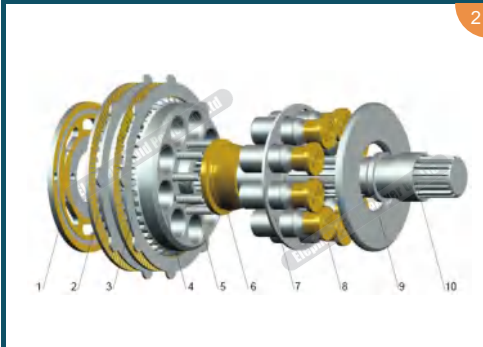

JMF-64/151-VBR/155

NO. 序号	Description 部件名称	Quantity/Set 数量/台
1	Valve Plate M (配油盘)	1
2	Friction Plate (摩擦片)	3
3	Seperation Plate (分隔片)	3
4	Cylinder Block (缸体)	1
5	Spring (弹簧)	9
6	Ball Guide (球铰)	1
7	Retainer Plate (回程盘)	1
8	Piston Shoe (柱塞滑靴)	9
9	Thrust Plate (止推板)	1
10	Drive Shaft (传动轴)	1

KOBELCO/KATO/神钢 加藤系列

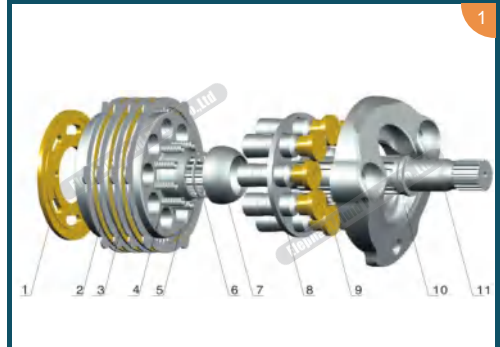

SK250-8/SK200-1/3/6/SK220-2/3/SK320/SK430/HYUNDAI 300-5 SWING MOTOR

NO. 序号	Description 部件名称	Quantity/Set 数量/台
1	Valve Plate (配油盘)	1
2	Friction Plate (摩擦片)	3
3	Seperation Plate (分隔片)	4
4	Cylinder Block (缸体)	1
5	Coli Spring (大弹簧)	9
6	Washer (垫块)	1
7	Ball Guide (球铰)	1
8	Retainer Plate (回程盘)	1
9	Piston Shoe (柱塞滑靴)	9
10	Swash Plate (摇摆)	1
11	Drive Shaft (传动轴)	1

KOBELCO/KATO/神钢 加藤系列

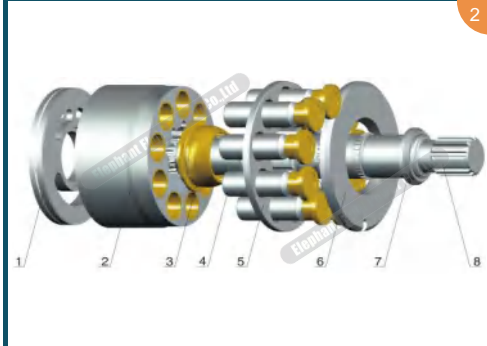

HD450V-2 KATO

NO. 序号	Description 部件名称	Quantity/Set 数量/台
1	Valve Plate (配油盘)	1
2	Cylinder Block (缸体)	1
3	Ball Guide (球铰)	1
4	Piston Shoe (柱塞滑靴)	9
5	Retainer Plate (回程盘)	1
6	Thrust Plate (止推板)	1
7	Back-UP Ring (卡簧)	1
8	Drive Shaft (传动轴)	1

KOBELCO/KATO/神钢 加藤系列

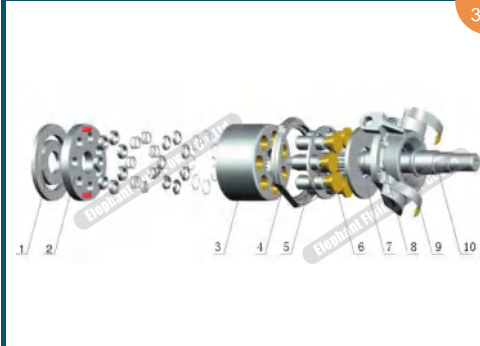

HD3000

NO. 序号	Description 部件名称	Quantity/Set 数量/台
1	Valve Plate M (配油盘)	1
2	Bearing Plate (衬板)	1
3	Cylinder Block (缸体)	1
4	Retainer (压板)	2
5	Retainer Plate (回程盘)	1
6	Piston Shoe (柱塞滑靴)	3
7	Ball Guide (球铰)	1
8	Thrust Plate (止推板)	11
9	Saddle Bearing (轴瓦)	1
10	Drive Shaft (传动轴)	1

KOBELCO/KATO/神钢 加藤系列

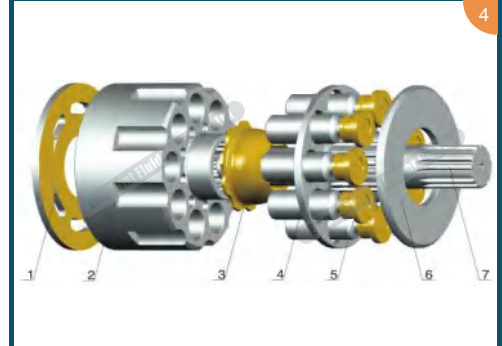

DH55/T3X128/DAEWOO 300-7/DH370 SWING MOTOR

NO. 序号	Description 部件名称	Quantity/Set 数量/台
1	Valve Plate (配油盘)	1
2	Cylinder Block (缸体)	1
3	Ball Guide (球铰)	1
4	Retainer Plate (回程盘)	1
5	Piston Shoe (柱塞滑靴)	9
6	Thrust Plate (止推板)	1
7	Drive Shaft (传动轴)	1

KOBELCO/KATO/神钢 加藤系列

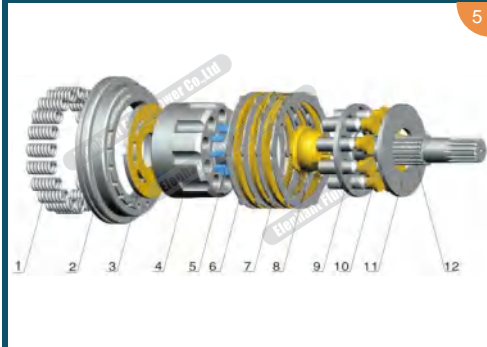

HYUNDAI 60-7/480 SWING MOTOR

NO. 序号	Description 部件名称	Quantity/Set 数量/台
1	Spring Seat Spring (小弹簧)	20
2	Spring Seat (弹簧座)	1
3	Valve Plate (配油盘)	1
4	Cylinder Block (缸体)	1
5	Ball Guide Spring (球铰弹簧)	9
6	Seperation Plate (分隔片)	4
7	Friction Plate (摩擦片)	3
8	Ball Guide (球铰)	1
9	Retainer Plate (回程盘)	1
10	Piston Shoe (柱塞滑靴)	9
11	Thrust Plate (止推板)	1
12	Drive Shaft (传动轴)	1

NABTESCO TRAVEL/纳博特斯克系列

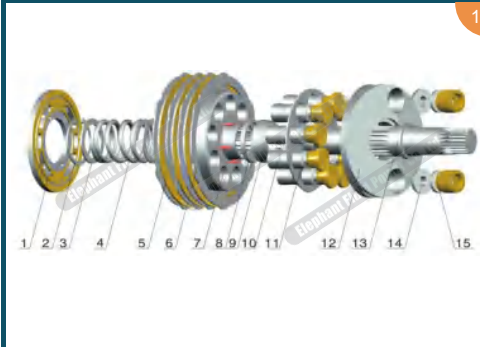

GM05VL/GM06VL/GM35VLPVD-2B-34/YC35-6/BOBCAT 337/CASE CS05A

NO. 序号	Description 部件名称	Quantity/Set 数量/台
1	Valve Plate M (配油盘)	1
2	Snap Ring (卡环)	1
3	Spacer (垫块)	2
4	Spring (弹簧)	1
5	Friction Plate (摩擦片)	3
6	Seperation Plate (分隔片)	4
7	Cylinder Block (缸体)	1
8	Spacer (垫块)	1
9	Ball Guide (球铰)	1
10	Piston Shoe (柱塞滑靴)	9
11	Retainer Plate (回程盘)	1
12	Swash Plate (摇摆)	1
13	Drive Shaft (传动轴)	1
14	Yoke Ball (支撑球)	2
15	Yoke Shoe (支撑柱塞)	2

NABTESCO TRAVEL/纳博特斯克系列

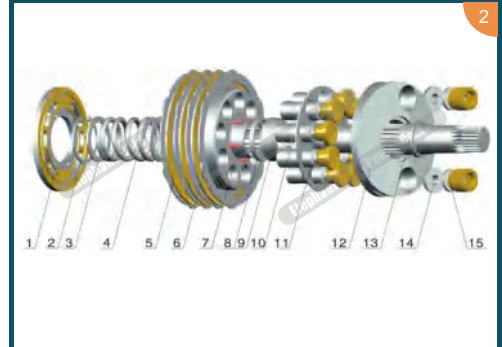

GM05-07VA/GM08-23/GM30H/GM35VA/GM38VB

NO. 序号	Description 部件名称	Quantity/Set 数量/台
1	Valve Plate M (配油盘)	1
2	Snap Ring (卡环)	1
3	Spacer (垫块)	2
4	Spring (弹簧)	1
5	Friction Plate (摩擦片)	3
6	Seperation Plate (分隔片)	4
7	Cylinder Block (缸体)	1
8	Spacer (垫块)	1
9	Ball Guide (球铰)	1
10	Piston Shoe (柱塞滑靴)	9
11	Retainer Plate (回程盘)	1
12	Swash Plate (摇摆)	1
13	Drive Shaft (传动轴)	1
14	Yoke Ball (支撑球)	2
15	Yoke Shoe (支撑柱塞)	2

大象流体动力

Elephant Fluid Power

NABTESCO TRAVEL/纳博特斯克系列

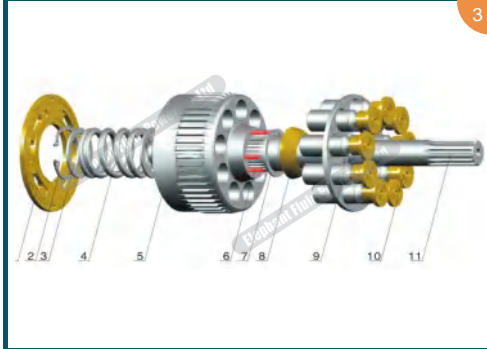

DNB08

NO. 序号	Description 部件名称	Quantity/Set 数量/台
1	Valve Plate (配油盘)	1
2	Snap Ring (卡环)	1
3	Spacer (垫块)	2
4	Spring (弹簧)	1
5	Cylinder Block (缸体)	1
6	Press Pin (顶针)	1
7	Spacer (垫块)	1
8	Ball Guide (球铰)	1
9	Retainer Plate (回程盘)	1
10	Piston Shoe (柱塞滑靴)	9
11	Drive Shaft (传动轴)	1

TADANO/多田野系列

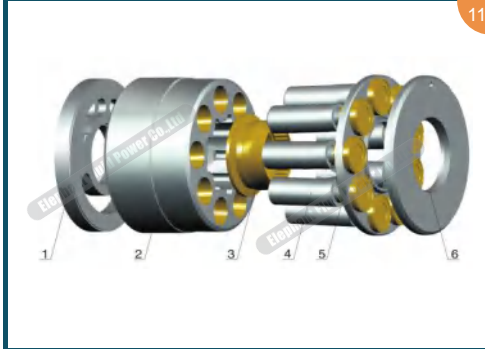

TADANO 100/150

NO. 序号	Description 部件名称	Quantity/Set 数量/台
1	Valve Plate (配油盘)	1
2	Cylinder Block (缸体)	1
3	Ball Guide (球铰)	1
4	Piston Shoe (柱塞滑靴)	9
5	Retainer Plate (回程盘)	1
6	Thrust Plate (止推板)	1

HARVESTER/收割机系列

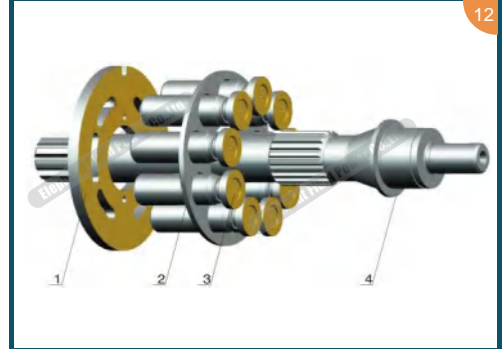

HPVMF23(T23C)/HPVMF23.7/T28C/T30C/T37C

NO. 序号	Description 部件名称	Quantity/Set 数量/台
1	Valve Plate R/M (配油盘)	1
2	Retainer Plate (回程盘)	1
3	Piston Shoe (柱塞滑靴)	9
4	Drive Shaft (传动轴)	1

REXROTH SERIES CONTROL VALVE



A6VM-EP2

REXROTH SERIES CONTROL VALVE



A6VM-HA

REXROTH SERIES CONTROL VALVE

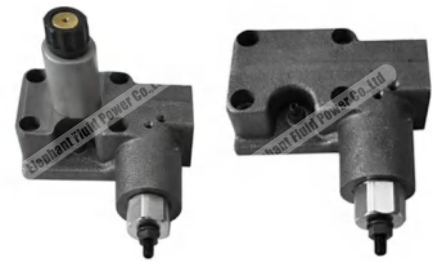

A6VM-HD1D

REXROTH SERIES CONTROL VALVE

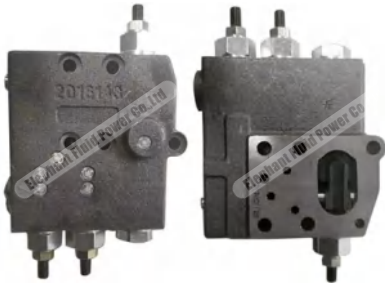

A11VO45/60/75-LRDS

REXROTH SERIES CONTROL VALVE



A11VO95/130/145-LE2S

REXROTH SERIES CONTROL VALVE



A11VO95/130/145-LRDS

REXROTH SERIES CONTROL VALVE

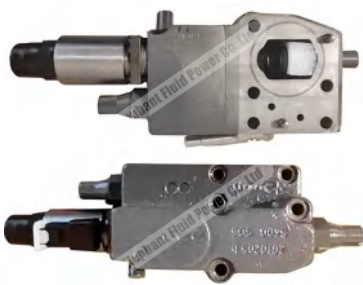

A11VO95/130/145-LRDU2

REXROTH SERIES CONTROL VALVE



A11VO190/260-LE2S

REXROTH SERIES CONTROL VALVE



A11VO190/260-LRDS

REXROTH SERIES CONTROL VALVE

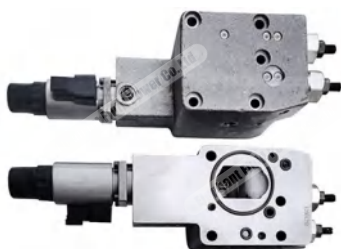

A11VO190/260-LRDU2

HAWE SERIES CONTROL VALVE

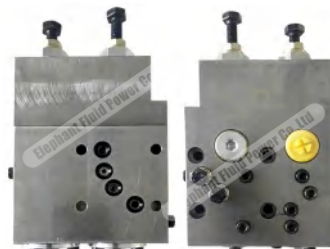

V30D

SAUER SERIES CONTROL VALVE



90R75/100

大象流体动力
Elephant Fluid Power

SAUER SERIES CONTROL VALVE

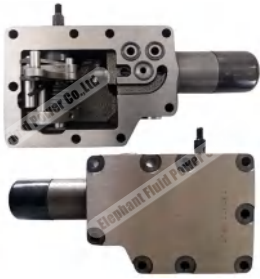

PV22/23

SAUER SERIES CONTROL VALVE

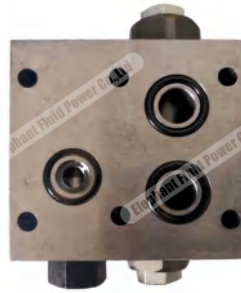

PV22/23

KAWASAKI SERIES CONTROL VALVE



K3V112

CHARGE PUMP



A4VG28-1

CHARGE PUMP

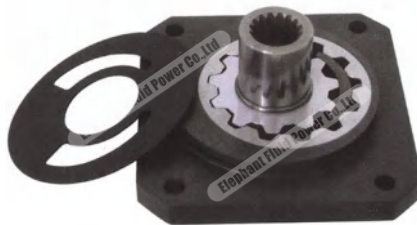

A4VG28-2

CHARGE PUMP



A4VG40-1

CHARGE PUMP



A4VG40-2

CHARGE PUMP



A4VG40-3

CHARGE PUMP



A4VG56-1



A4VG56-2



A4VG71-1



A4VG71-2

CHARGE PUMP



A4VG90-1

CHARGE PUMP



A4VG90-2

CHARGE PUMP



A4VG90-3

CHARGE PUMP



A4VG125-1

CHARGE PUMP



A4VG125-2

CHARGE PUMP



A4VG125-3

CHARGE PUMP



A4VG180-1

CHARGE PUMP



A4VG250-1

CHARGE PUMP



A4VG250-2

CHARGE PUMP



A4VTG71-1

CHARGE PUMP



A4VTG90-1

CHARGE PUMP



A4VTG90-2

CHARGE PUMP



A10VG28

CHARGE PUMP



A10VG45

CHARGE PUMP



A10VG63-1

CHARGE PUMP



A10VG63

CHARGE PUMP



SPV6/119

CHARGE PUMP



PV90R42

CHARGE PUMP



PV90R55

CHARGE PUMP



PV90R75/100

CHARGE PUMP



PV90R130



BMM SERIES HYDRAULIC MOTOR

BMM series motor are small volume, economical type, which is designed with shaft distribution flow, which adapt the Gerotor gear set design and provide compact volume, high power and low weight.

Characteristic features:

- * Advanced manufacturing devices for the Gerotor gear set, which provide small volume, high efficiency and long life.
- * Shaft seal can bear high pressure of motor of which can be used in parallel or in series.
- * Advanced construction design, high power and low weight.

Main Specification

Type		BMM 8	BMM 12.5	BMM 20	BMM 32	BMM 40	BMM 50
Geometric displacement (cm ³ /rev.)		8.2	12.9	19.9	31.6	39.8	50.3
Max. speed (rpm)	cont.	1950	1550	1000	630	500	400
	int.	2450	1940	1250	800	630	500
Max. torque (N•m)	cont.	11	16	25	40	45	46
	int.	15	23	35	57	70	88
	peak	21	33	51	64	82	100
Max. output (kW)	cont.	1.8	2.4	2.4	2.4	2.2	1.8
	int.	2.6	3.2	3.2	3.2	3.2	3.2
Max. pressure drop (MPa)	cont.	10	10	10	10	9	7
	int.	14	14	14	14	14	14
	peak	20	20	20	16	16	16
Max. flow (L/min)	cont.	16	20	20	20	20	20
	int.	20	25	25	25	25	25
Weight (kg)		1.9	2	2.1	2.2	2.3	2.4

Type		Max.inlet pressure
BMM8-50 (MPa)	cont.	17.5
	int.	22.5

- * Continuous pressure:Max. value of operating motor continuously.
- * Intermittent pressure :Max. value of operating motor in 6 seconds per minute.
- * Peak pressure:Max. value of operating motor in 0.6 second per minute.

BMP SERIES HYDRAULIC MOTOR

BMP series motor are small volume, economical type, which is designed with shaft distribution flow, which adapt the Gerotor gear set design and provide compact volume, high power and low weight.

Characteristic features:

- * Advanced manufacturing devices for the Gerotor gear set, which provide small volume, high efficiency and long life.
- * Shaft seal can bear high pressure of motor of which can be used in parallel or in series.
- * Advanced construction design, high power and low weight.



Main Specification

Type		BMP	BMP	BMP	BMP	BMP	BMP	BMP	BMP	BMP	BMP	BMP
		BMPH BMPW 36	BMPH BMPW 50	BMPH BMPW 80	BMPH BMPW 100	BMPH BMPW 125	BMPH BMPW 160	BMPH BMPW 200	BMPH BMPW 250	BMPH BMPW 315	BMPH BMPW 400	BMPH BMPW 400
Geometric displacement (cm ³ /rev.)		36	51.7	77.7	96.2	120.2	157.2	194.5	240.3	51.7	389.5	486.5
Max. speed (rpm)	cont.	1500	1150	770	615	490	383	310	250	192	155	120
	int.	1650	1450	960	770	615	475	385	310	240	190	150
Max. torque (N•m)	cont.	55	100	146	182	236	302	360	380	375	360	385
	int.	76	128	186	227	290	370	440	460	555	525	560
	peak	96	148	218	264	360	434	540	550	650	680	680
Max. output (kW)	cont.	8.0	10.0	10.0	11.0	10.0	10.0	10.0	8.5	7.0	6.0	5.0
	int.	11.5	12.0	12.0	13.0	12.0	12.0	12.0	10.5	8.5	7.0	6.0
Max. pressure drop (MPa)	cont.	12.5	14	14	14	14	14	14	11	9	7	6
	int.	16.5	17.5	17.5	17.5	17.5	17.5	17.5	14	14	10.5	9
	peak	22.5	22.5	22.5	22.5	22.5	22.5	22.5	18	16	14	12
Max. flow (L/min)	cont.	55	60	60	60	60	60	60	60	60	60	60
	int.	60	75	75	75	75	75	75	75	75	75	75
Weight (kg)		5.6	5.6	5.7	5.9	6.0	6.2	6.4	6.7	6.9	7.4	8

* Continuous pressure:Max. value of operating motor continuously.

* Intermittent pressure :Max. value of operating motor in 6 seconds per minute.

* Peak pressure:Max. value of operating motor in 0.6 second per minute.

BMR SERIES HYDRAULIC MOTOR



BMR series motor adapt the advanced Geroler gear set design with shaft distribution flow, which can automatically compensate in operating with high pressure, provide reliable and smooth operation, high efficiency and long life.

Characteristic features:

- *Advanced manufacturing devices for the Gerolor gear set, which use low pressure of start-up, provide smooth, reliable operation and high efficiency.
- *Shaft seal can bear high pressure of back and the motor can be used in parallel or in series.
- *Special design in the driver-linker and prolong operating life
- *Special design for distribution system can meet the requirement of low noise of unit.
- *Compact volume and easy installation

Main Specification

Type		BMR	BMR	BMR	BMR	BMR	BMR	BMR	BMR	BMR	
		BMRS	BMRS	BMRS	BMRS	BMRS	BMRS	BMRS	BMRS	BMRS	BMRS
		36	50	80	100	125	160	200	250	315	375
Geometric displacement (cm ³ /rev.)		36	51.7	81.5	102	127.2	157.2	194.5	253.3	317.5	381.4
Max. speed (rpm)	cont.	1085	960	750	600	475	378	310	240	190	155
	int.	1220	1150	940	750	600	475	385	300	240	190
Max. torque (N•m)	cont.	72	100	195	240	300	360	360	390	390	365
	int.	83	126	220	280	340	430	440	490	535	495
	peak	105	165	270	320	370	460	560	640	650	680
Max. output (kW)	cont.	8.5	9.5	12.5	13.0	12.5	12.5	10.0	7.0	6.0	5.0
	int.	9.8	11.2	15.0	15.0	14.5	14.0	13.0	9.5	9.0	8.0
Max. pressure drop (MPa)	cont.	14.0	14	17.5	17.5	17.5	16.5	13	11	9	7
	int.	16.5	17.5	20	20	20	20	17.5	15	13	10
	peak	22.5	22.5	22.5	22.5	22.5	22.5	22.5	20	17.5	15
Max. flow (L/min)	cont.	40	50	60	60	60	60	60	60	60	60
	int.	45	60	75	75	75	75	75	75	75	75
Weight (kg)		6.5	6.7	6.9	7	7.3	7.6	8.0	8.5	9.0	9.5

- * Continuous pressure:Max.value of operating motor continuously.
- * Intermittent pressure:Max.value of operating motor in 6 seconds per minute .
- * Peak pressure:Max.value of operating motor in 0.6 second per minute.

BMH SERIES HYDRAULIC MOTOR

BMH series motor adapt the advanced Geroler gear set design with shaft distribution flow, which can automatically compensate in operating with high pressure, provide reliable and smooth operation, high efficiency and long life.

Characteristic features:

- *Advanced manufacturing devices for the Gerolor gear set, which use low pressure of start-up, provide smooth, reliable operation and high efficiency.
- *Shaft seal can bear high pressure of back and the motor can be used in parallel or series.
- *Special design in the driver-linker and prolong operating life.
- *Special design for distribution system can meet the requirement of low noise of unit.
- *Compact volume and easy installation.



Main Specification

Type		BMH 200	BMH 250	BMH 315	BMH 400	BMH 500
Geometric displacement (cm ³ /rev.)		203.2	255.9	316.1	406.4	489.2
Max. speed (rpm)	cont.	366	290	236	183	155
	int.	439	348	282	220	166
Max. torque (N•m)	cont.	510	621	740	850	830
	int.	579	702	827	990	1040
	peak	651	790	980	1092	1170
Max. output (kW)	cont.	16	16	14	12.5	11
	int.	18.5	18.5	15.5	15	14
Max. pressure drop (MPa)	cont.	17.5	17.5	17.5	15.5	12.5
	int.	20	20	20	19	16
	peak	22.5	22.5	22.5	21	18
Max. flow (L/min)	cont.	75	75	75	75	75
	int.	90	90	90	90	90
Weight (kg)		10.5	11	11.5	10.5	10.5

Type		Max.inlet pressure	Max.return pressure with drain line
BMH200-500 (MPa)	cont.	200	175
	int.	225	200
	peak	250	225

- * Continuous pressure :Max. value of operating motor continuously.
- * Intermittent pressure :Max. value of operating motor in 6 seconds per minute.
- * Peak pressure:Max. value of operating motor in 0.6 second per minute.
- * Technical data BMH with 35mm cylindrical, 11/4 in splined and 35mm tapered shaft.

BMSY SERIES HYDRAULIC MOTOR

BMSY new series motor adapt the advanced Geroler gear set designed with disc distribution flow and high pressure. The unit can be supplied the individual variant in operating multifunction in accordance with requirement of applications.

Characteristic features:

- * Advanced manufacturing devices for the Geroler gear set, which use low pressure of start-up, provide smooth and reliable operation and high efficiency.
- * The output shaft adapts in tapered roller bearings that permit high axial and radial forces. The case can offers capacities of high pressure and high torque in the wide of applications.
- * Advanced design in disc distribution flow, which can automatically compensate in operating with high volume efficiency and long life , provide smooth and reliable operation.
- * The new series motor is suitable for vehicles with greater loads and pressure drop.



Main Specification

Type		BMSY	BMSY	BMSY	BMSY	BMSY	BMSY	BMSY	BMSY	
		BMSYS	BMSYS	BMSYS	BMSYS	BMSYS	BMSYS	BMSYS	BMSYS	
		80	100	125	160	200	250	315	400	475
Geometric displacement (cm ³ /rev.)		80.6	100.8	125	154	194	243	311	394	475
Max. speed (rpm)	cont.	800	748	600	470	375	300	240	185	155
	int.	988	900	720	560	450	360	280	225	185
Max. torque (N•m)	cont.	225	290	365	485	586	708	880	880	910
	int.	305	390	480	590	705	860	1000	980	990
Max. output (kW)	cont.	16	18	18	18.1	18.1	18	17	11	9
	int.	20	22	23	25	24	23.8	20.2	12	11
Max. pressure drop (MPa)	cont.	20.5	20.5	20.5	21	21	20	20	16	14
	int.	27.5	27.5	27.5	26	25	25	24	19	15
	peak	29.5	29.5	29.5	28	27	27	26	21	17.5
Max. flow (L/min)	cont.	65	75	75	75	75	75	75	75	75
	int.	80	90	90	90	90	90	90	90	90
Max. inlet pressure (MPa)	cont.	25	25	25	25	25	25	25	25	25
	int.	30	30	30	30	30	30	30	30	30
Weight (kg)		9.8	10	10.3	10.7	11.1	11.6	12.3	13.2	14.3

- * Continuous pressure :Max. value of operating motor continuously.
- * Intermittent pressure :Max. value of operating motor in 6 seconds per minute.
- * Peak pressure:Max. value of operating motor in 0.6 second per minute.

BMT SERIES HYDRAULIC MOTOR

BMT series motor adapt the advanced Geroler gear set design with disc distribution flow and high pressure. The unit can be supplied the individual variant in operating multifunction in accordance with requirement of applications.

Characteristic features:

- * Advanced manufacturing devices for the Geroler gear set, which use low pressure of start-up, provide smooth and reliable operation and high efficiency.
- * The output shaft adapts in tapered roller bearings that permit high axial and radial forces. Can offer capacities of high pressure and high torque in the wide of applications.
- * Advanced design in disc distribution flow, which can automatically compensate in operating with high volume efficiency and long life, provide smooth and reliable operation.



Main Specification

Type		BMT 160	BMT 200	BMT 230	BMT 250	BMT 315	BMT 400	BMT 500	BMT 630	BMT 800
Geometric displacement (cm ³ /rev.)		161.1	201.4	232.5	251.8	326.3	410.9	523.6	629.1	801.8
Max. speed (rpm)	cont.	625	625	536	500	380	305	240	196	154
	int.	780	750	643	600	460	365	285	233	185
Max. torque (N•m)	cont.	470	590	670	730	950	1080	1220	1318	1464
	int.	560	710	821	880	1140	1260	1370	1498	1520
	peak	669	838	958	1036	1346.3	1450.3	1643.8	1618.8	1665
Max. output (kW)	cont.	27.7	34.9	34.7	34.5	34.9	31.2	28.8	25.3	22.2
	int.	32	40	40	40	40	35	35	27.5	26.8
Max. pressure drop (MPa)	cont.	20	20	20	20	20	18	16	14	12.5
	int.	24	24	24	24	24	21	18	16	13
	peak	28	28	28	28	28	24	21	19	16
Max. flow (L/min)	cont.	100	125	125	125	125	125	125	125	125
	int.	125	150	150	150	150	150	150	150	150
Max. inlet pressure (MPa)	cont.	21	21	21	21	21	21	21	21	21
	int.	25	25	25	25	25	25	25	25	25
	peak	30	30	30	30	30	30	30	30	30
Weight (kg)		19.5	20	20.4	20.5	21	22	23	24	25

- * Continuous pressure :Max. value of operating motor continuously.
- * Intermittent pressure :Max. value of operating motor in 6 seconds per minute.
- * Peak pressure:Max. value of operating motor in 0.6 second per minute.



BMV SERIES HYDRAULIC MOTOR

BMV series motor adapt the advanced Geroler gear set designed with disc distribution flow and high pressure. The unit can be supplied the individual variant in operating multifunction in accordance with requirement of applications.

Characteristic features:

- * Advanced manufacturing devices for the Geroler gear set, which use low pressure of start up, provide smooth and reliable operation and high efficiency.
- * The output shaft adapts in tapered roller bearings that permit high axial and radial forces. The case can offer capacities of high pressure and high torque in the wide of applications.

* Advanced design in disc distribution flow, which can automatically compensate in operating with high volume efficiency and long life, provide smooth and reliable operation.

Main Specification

Type		BMV 315	BMV 400	BMV 500	BMV 630	BMV 800	BMV 1000
Geometric displacement (cm ³ /rev.)		333	419	518	666	801	990
Max. speed (rpm)	cont.	510	500	400	320	230	200
	int.	630	600	480	380	300	240
Max. torque (N•m)	cont.	920	1180	1460	1660	1880	2015
	int.	1110	1410	1760	1940	2110	2280
	peak	1290	1640	2050	2210	2470	2400
Max. output (kW)	cont.	38.0	47.0	47.0	40.0	33.0	28.6
	int.	46.0	56.0	56.0	56.0	44.0	40.0
Max. pressure drop (MPa)	cont.	20	20	20	18	16	14
	int.	24	24	24	21	18	16
	peak	28	28	28	24	21	18
Max. flow (L/min)	cont.	160	200	20	20	20	20
	int.	200	240	25	25	25	25
Weight (kg)		1.9	2	2.1	2.2	2.3	2.4

* Continuous pressure :Max. value of operating motor continuously.

* Intermittent pressure :Max. value of operating motor in 6 seconds per minute.

* Peak pressure:Max. value of operating motor in 0.6 second per minute.

BMK2 SERIES HYDRAULIC MOTOR

BMK2 new series motor adapt the advanced Geroler gear set designed with disc distribution flow and high pressure. The unit can be supplied the individual variant in operating multifunction in accordance with requirement of applications.

Characteristic features:

- * Advanced manufacturing devices for the Geroler gear set, which use low pressure of start-up, provide smooth and reliable operation and high efficiency.
- * The output shaft adapts in tapered roller bearings that permit high axial and radial forces. The case can offers capacities of high pressure and high torque in the wide of applications.
- * Advanced design in disc distribution flow, which can automatically compensate in operating with high volume efficiency and long life , provide smooth and reliable operation.
- * The new series motor is suitable for vehicles with greater loads and pressure drop.



Main Specification

Type		BMK2 65	BMK2 80	BMK2 100	BMK2 125	BMK2 160	BMK2 200	BMK2 250	BMK2 315	BMK2 400	BMK2 475
Geometric displacement (cm ³ /rev.)		65	80	100.9	129.8	156.8	193.4	242.5	304.3	390.8	485
Max. speed (rpm)	cont.	835	800	742	576	477	308	310	246	191	153
	int.	990	980	924	720	713	462	385	365	287	230
Max. torque (N•m)	cont.	185	235	295	385	455	660	360	765	775	845
	int.	245	345	445	560	570	820	440	885	925	930
Max. pressure drop (MPa)	cont.	20.5	21	21	21	20.5	20.5	14	21	15.5	12
	int.	27.5	31	31	31	26	26	17.5	24	17	14
	peak	31	31	31	31	31	31	22.5	31	20.5	17
Max. flow (L/min)	cont.	55	65	75	75	75	75	75	75	75	75
	int.	65	80	95	95	115	115	115	115	115	115
Weight (kg)		5.6	5.6	5.7	5.9	6.0	6.2	6.4	6.7	6.9	7.4

- * Continuous pressure:Max. value of operating motor continuously.
- * Intermittent pressure :Max. value of operating motor in 6 seconds per minute.
- * Peak pressure:Max. value of operating motor in 0.6 second per minute.

BMK6 SERIES HYDRAULIC MOTOR

BMK6 series motor adapt the advanced Geroler gear set designed with disc distribution flow and high pressure. The unit can be supplied the individual variant in operating multifunction in accordance with requirement of applications.

Characteristic features:

- * Advanced manufacturing devices for the Geroler gear set, which use low pressure of start-up, provide smooth and reliable operation and high efficiency.
- * Advanced design in disc distribution flow, which can automatically compensate in operating with high volume efficiency and long life, provide smooth and reliable operation.
- * Shaft seal can bear high pressure of back.

* The output shaft adapts in tapered roller bearings that permit high axial and radial forces. The case can offers capacities of high pressure and high torque in the wide of applications.



Main Specification

Type		BMK6 200	BMK6 250	BMK6 315	BMK6 400	BMK6 500	BMK6 630	BMK6 800	BMK6 1000
Geometric displacement (cm ³ /rev.)		195.6	246.1	311.6	391.3	490.8	623	802.4	981.6
Max. speed (rpm)	cont.	765	610	480	382	304	240	186	152
	int.	865	830	690	570	455	380	280	230
Max. torque (N•m)	cont.	565	710	920	1160	1445	1480	1580	1675
	int.	840	1080	1325	1625	1880	1890	1880	1860
Max. pressure drop (MPa)	cont.	20	20	20	20	20	17.5	14	14
	int.	30	30	30	30	27.5	22.5	15.5	14
	peak	30	30	30	30	30	24	17.5	17
Max. flow (L/min)	cont.	150	50	60	60	150	150	150	150
	int.	170	60	75	75	225	225	225	225
Weight (kg)		26.3	26.8	27.3	28	28.8	29.6	30.5	32

*Continuous pressure:Max.value of operating motor continuously.

*Intermittent pressure:Max.value of operating motor in 6 seconds per minute .

*Peak pressure:Max.value of operating motor in 0.6 second per minute.

BMER SERIES HYDRAULIC MOTOR

BMER series motor adapt the advanced Geroler gear set designed with high speed distribution flow and high pressure, and have good stability in low speed , and can keep high volume efficiency. The unit can be supplied the individual variant in operating multifunction in accordance with requirement of applications.

Characteristic features:

- * Advanced manufacturing devices for the Geroler gear set, which use low pressure of start up, provide smooth and reliable operation and high efficiency.
- * The output shaft adapts in needle roller bearings that permit high axial and radial forces. The case can offers capacities of high pressure and high torque in the wide of applications.
- * Advanced design in high speed distribution flow, which can automatically compensate in operating with high volume efficiency and long life , provide smooth and reliable operation.
- * Lowest leakage rate, most accurate timing methods. Commutator rotates 6x faster than shaft speed. It make the distribution in a high precision reduces life-cycle cost, maintain high volume efficiencies and can run very smoothly at low speed, gear box not required.



Main Specification

Main Specification

Type		BMER 125	BMER 160	BMER 200	BMER 230	BMER 250	BMER 300	BMER 350	BMER 375	BMER 400	BMER 475	BMER 540	BMER 650	BMER 750
Geometric displacement (cm ³ /rev.)		118	156	196	228	257	296	345	371	405	462	540	647	745
Max. speed (rpm)	cont.	360	375	330	290	290	250	220	200	185	160	140	115	100
	int.	490	470	425	365	350	315	270	240	220	195	170	138	120
Max. torque (N•m)	cont.	325	450	530	625	700	810	905	990	1010	1085	980	1015	1050
	int.	380	525	600	710	790	930	1035	1140	1180	1180	1240	1250	1180
	peak	450	590	750	870	980	1120	1285	1360	1360	1260	1380	1380	1370
Max. output (kW)	cont.	12.0	15.0	15.5	15.0	15.0	18.0	17.5	16.5	15.5	14.5	11.5	10.0	8.0
	int.	14.0	17.5	18.0	17.5	17.5	21.0	20.0	19.0	18.0	16.5	15.0	12.0	10.0
Max. pressure drop (MPa)	cont.	20.5	20.5	20.5	20.5	20.5	20.5	20.5	20.5	19	17.5	14	12	10.5
	int.	24	24	24	24	24	24	24	24	22.5	19	17.5	15.5	12
	peak	27.6	27.6	27.6	27.6	27.6	27.6	27.6	27.6	25	20.5	20.5	17.5	14
Max. flow (L/min)	cont.	45	60	70	70	75	80	80	75	75	75	75	75	75
	int.	60	75	85	85	90	95	95	90	90	90	90	90	90

*Continuous pressure:Max.value of operating motor continuously.

*Intermittent pressure:Max.value of operating motor in 6 seconds per minute .

*Peak pressure:Max.value of operating motor in 0.6 second per minute.

Hydraulic Steering Control Units (SCU)

BZZ1, BZZ2, BZZ3 series



Displacement (mL/r)
50,63,80,100,125,160,200,250,
280,315,400,500,630,800,1000

BZZ5 series



Displacement (mL/r)
50,63,80,100,125,160,200,250,
280,315,400,500,630,800,1000

060-1, 2, 4 series



Displacement (mL/r)
50,63,80,100,125,160,200,
250,280,315,400

101-1, 2, 3 series



Displacement (mL/r)
50,63,80,100,125,160,200,
250,280,315,400

101S-1, 2, 3 series



Displacement (mL/r)
50,63,80,100,125,160,200,
250,280,315,400

105 series



Displacement (mL/r)
73.8

112AS series



Displacement (mL/r)
125,160

109 series



Displacement (mL/r)
20,32,40,50,63,80

PV Type Priority Valves



Max. Input Flow (L/min)
40,60,80

Hydraulic Control Valve

DCV series



Nominal flow rate (L/min)

20, 40, 45, 60, 100, 140, 200

Main Specification

Type	Nominal Flow Rate	Max Pressure	Operating Range	Viscosity		Structure
				min	max	
DCV20	20 L/min	350 bar	15~75mm ² /S	12 mm ² /S	400 mm ² /S	Monoblock: 6 sections
DCV40	40 L/min					Monoblock: 1~8 sections
DCV45	45 L/min					Monoblock: 1~8 sections
DCV60	60 L/min					Sectional: 1~12 sections
DCV100	100 L/min					Sectional: 1~12 sections
DCV140	140 L/min					Sectional: 1~12 sections
DCV200	200 L/min					Sectional: 1~12 sections

P40/80 series



Nominal flow rate (L/min)

40, 80

Main Specification

Type	Nominal Flow Rate	Max Pressure	Operating Range	Viscosity		Structure
				min	max	
P40	40 L/min	250 bar	15~75mm ² /S	12 mm ² /S	400 mm ² /S	Monoblock: 1~7 sections
P80	80 L/min					

HSV6 series



Max flow (L/min)

50, 80

Main Specification

Type	Max flow	Rated pressure	Oli temp range
HSV6	50L/min	25 Mpa	- 20° ~80° C

Hydraulic Vane Pump And Spare Parts

T6, T7 series



V10, V20 series



VQ series



SQP series



PFE, PFED series



PV2R series



T6DR, T6ER series



Low pressure variable vane pumps



Hydraulic Vane Pump Cartridge kit



专业做液压-专注做精品

PROFESSIONAL ON HYDRAULIC- FOCUS ON HIGH QUALITY

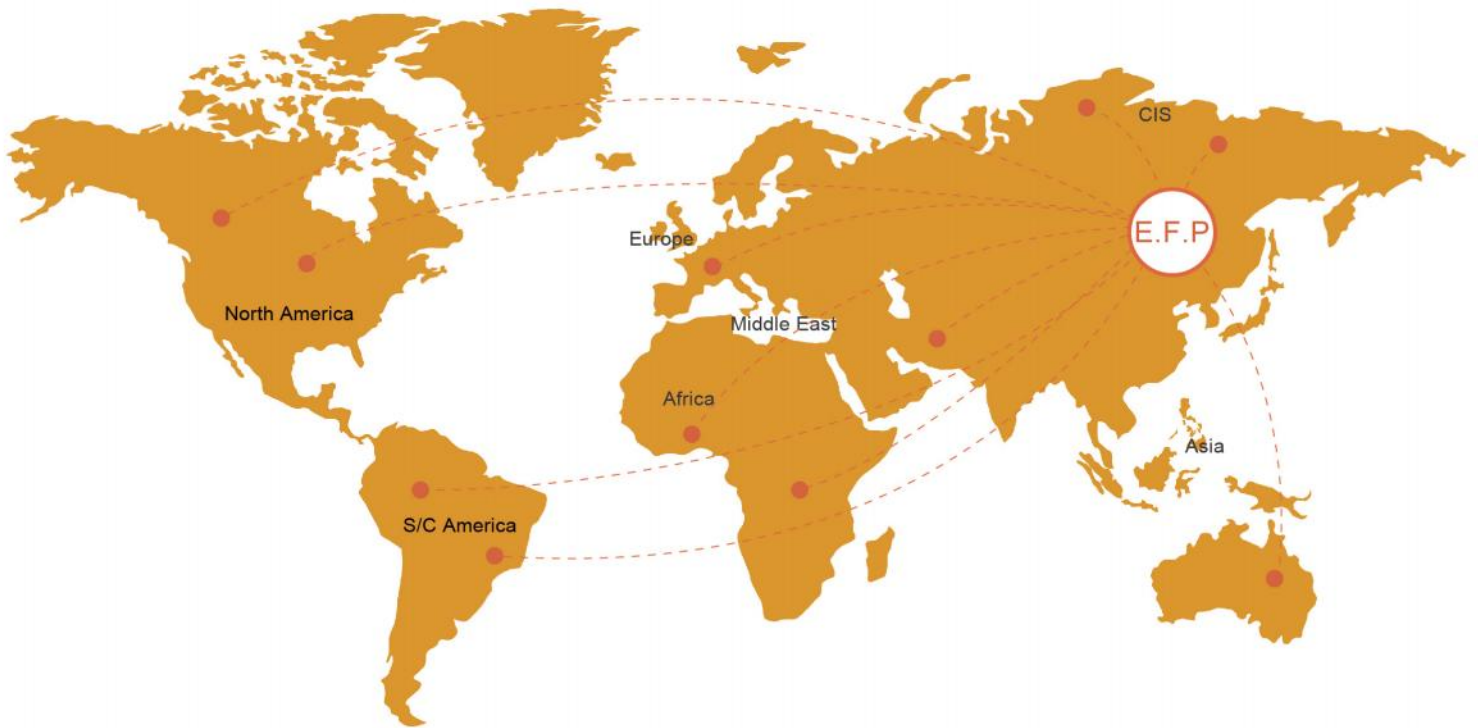

大象流体动力有限公司

地址:中国河北石家庄友谊北大街398号

电话: +86 (311) 68123061

传真: +86 (10) - 80115555- 568844

邮编: 050000

网址: www.heavyequipmentmaintain.com/

邮箱: manager@sjzhjms.com

Elephant Fluid Power Co.,Ltd

Add: No. 398 Youyi Street, Shijiazhuang, Hebei, China

Tel: +86 (311) 68123061

Fax: +86 (10) - 80115555-568844

Post code: 050000

Web: www.heavyequipmentmaintain.com/

Email: manager@sjzhjms.com