



三联机械
S.L. MACHINERY

HZS Series Concrete Batching Plant

One stop solution for batching plant

Jerry Zhuang

Sales Manager

Cell:+86-13515040568

About us 30+ years, 80+ countries and regions...



office building



workshop1



workshop 2

S.L Machinery has 140,000m² of modern industrial park and 50,000m² of standard workshop, we fully implement **ISO 9001** Quality Management System, **ISO14001** Environment Management System, **OHSAS 18001** System, and our products have been granted **CE** Certificate

S.L Machinery focus on manufacturing kinds of batching plants, to make it simple, more functional ,less energy consumption, easy control, easy to move, less emission.....

Let me know what you need, welcome to join us!!

From Design & Manufacturing to On-site service...

Negotiation



Design



Processing



Welding

Assembling



Function test

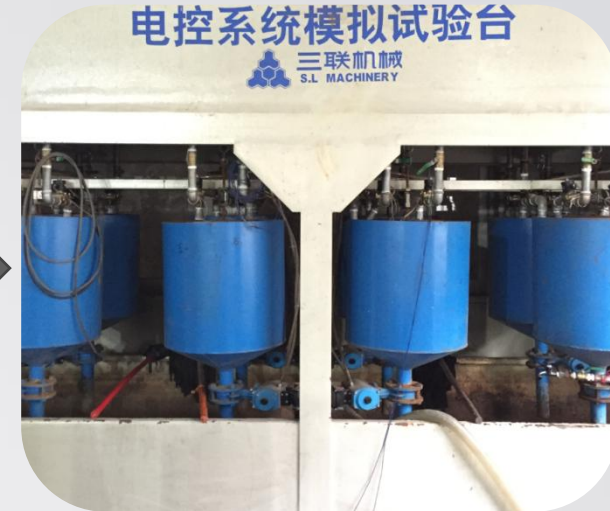

Painting



Customer inspection



Cargo packing



Container loading



Installation on site



Job site revisiting



Main parts of Concrete Batching Plant

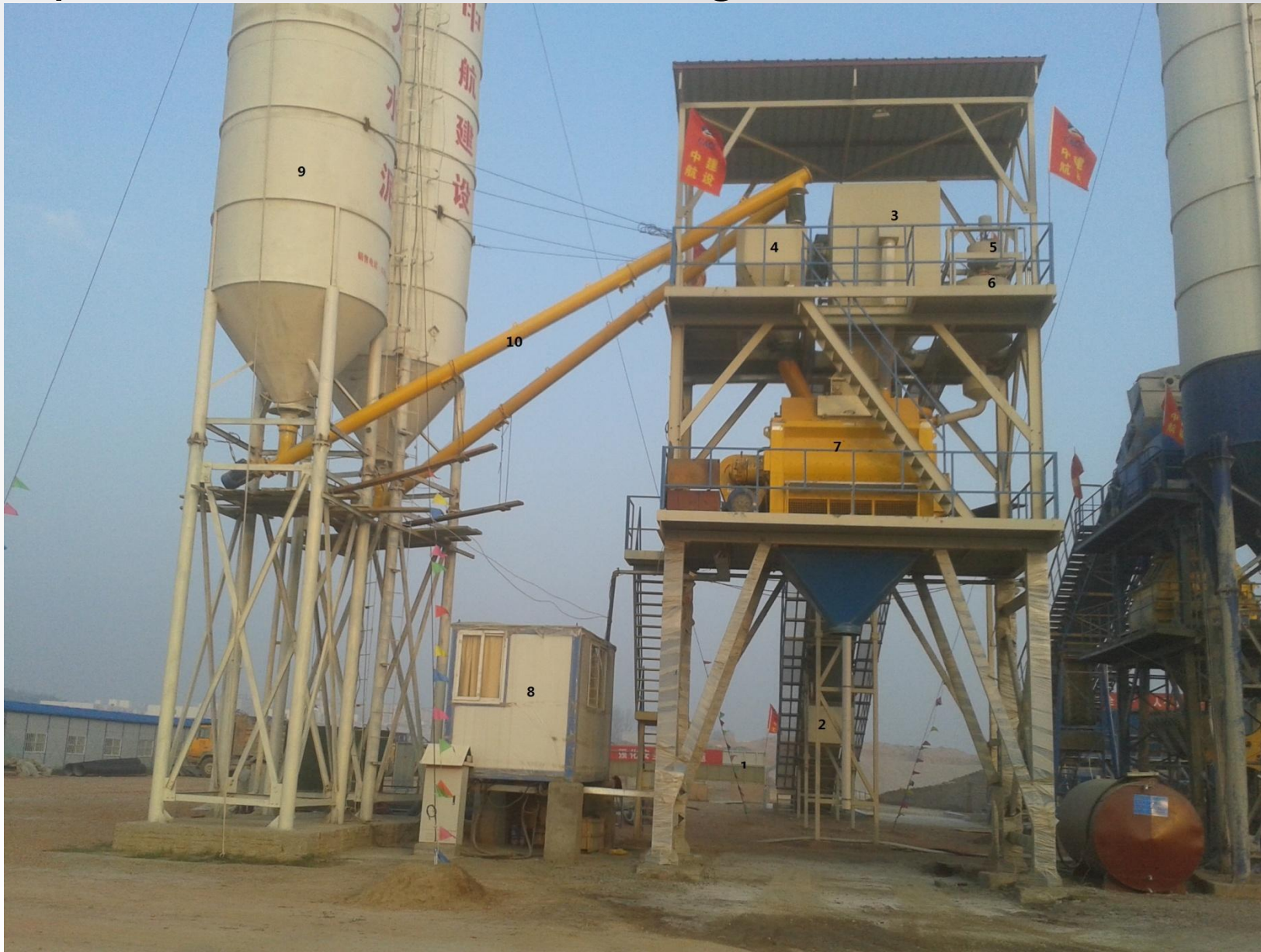

1. Aggregate batcher
2. Inclined belt conveyor
3. Transit hopper
4. Cement weighing system
5. Additive weighing system
6. Water weighing system
7. Twin-shaft mixer
8. Control system
9. Cement silo
10. Screw conveyor

1. Aggregate Batcher

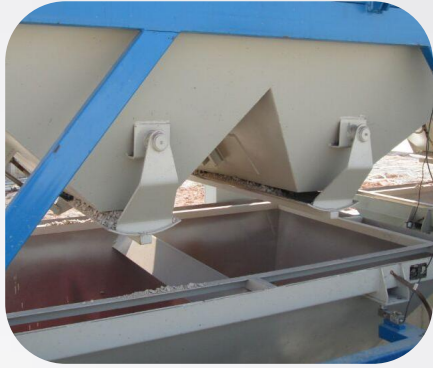

- 4+4mm thickness pressed sheet steel
- heavy pressed steel frame
- double outlet door



WAM-OLI VIBRATOR :
avoid stick and feeding smooth



USA TOLEDO LOADCELL:
stainless steel and durable use

high and stable weighing accuracy



GUOMAO MOTOR & GEAR BOX:
easy to do maintenance

running low temperature, extend work life

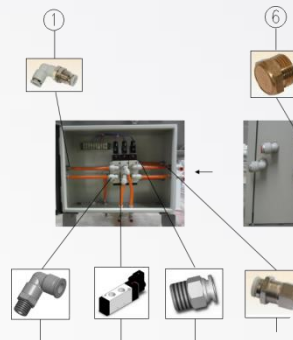

TAIWAN AIRTAC AIR CYLINDER/ SOLENOID VALVE:
control the gate open /close fast and sensitive

pre-pipe the air line and control cable in a terminal control box, easy to find the source, durable use and beautiful.

- ◆ Each weighing system works independently at the same time.
- ◆ 3 loadcells for each hopper
- ◆ **Fast and high accuracy !!!**

2. Belt conveyor



Support roller:

- polished surface, running fast and less wear out of belt
- imported bearing, stable and durable
- smart design, faster and easier for replacing



Rain cover & side aisle:

- color corrugation panel looks beauty and reduce the dust emission
- to avoid the damage direct from sunshine and rain
- double side aisle, easy to do maintenance and safety.



GUOMAO shaft mounted reducer:

- Changeable frictional encapsulate drum, the maintenance can be done in half an hour, with real time-saving
- equiped alloy cleaner make belt running smooth and expend life time

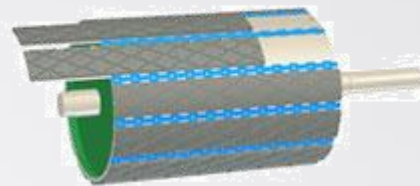

- ◆ 5 layers canvas endless belt, up to 12mm, strong and long life
- ◆ heavy duty steel frame
- ◆ option for trough belt, chevron belt and plane belt.

3. Aggregate transit hopper

- ◆ when the 1st batch mixing , the 2nd batch weighing at the same time, and the weighed aggregate storage here
- ◆ mounted on the top of the mixer, can feed the aggregate in 5 seconds
- ◆ short the time of aggregate dosing and conveying , more efficiency and guarantee the production.
- ◆ equipped **WAM-OLI vibrator** and **TAIWAN AIRTAC air cylinder**

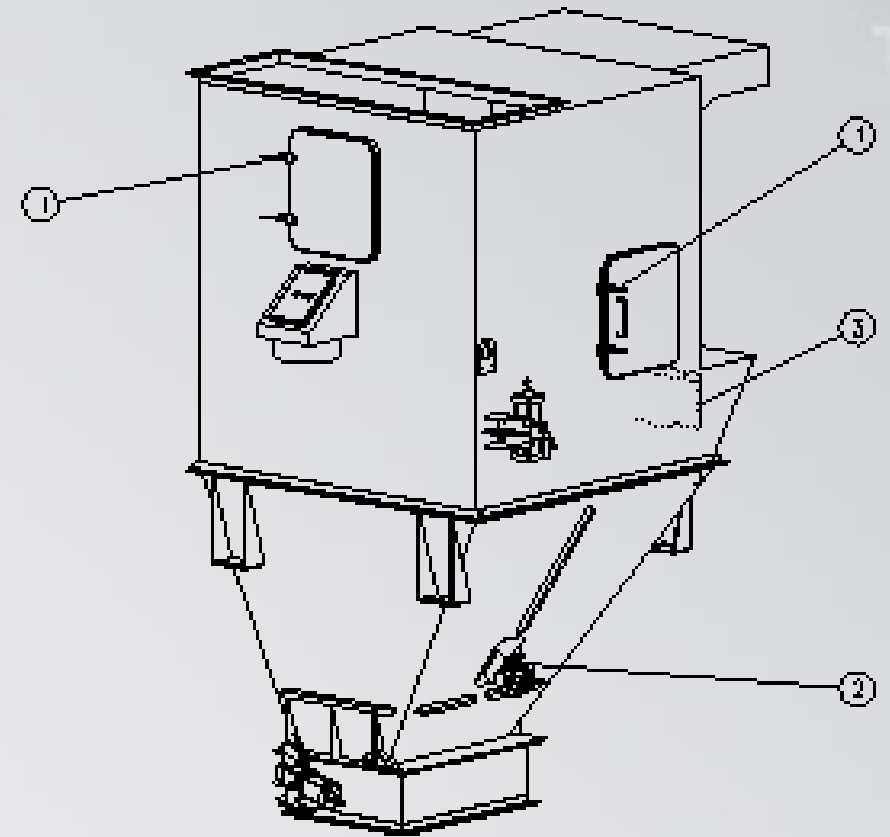

4. Cement & Fly ash weighing



USA TOLEDO loadcell:

- 3 nos load cell for each bin, high accuracy
- equiped shield copper tape protect the loadcell to avoid the damage from lightning



- Reasonable permeability design can balance filler pressure and effectively avoid impacts on the weighing bin

- Equiped **WAM-OLI vibrator**



ITALY SICOMA pneumatic butterfly valve:

- with identical top and bottom flange, easy to connect
- High-pressure, aluminium alloy die-cast semi-bodies, long lifetime.

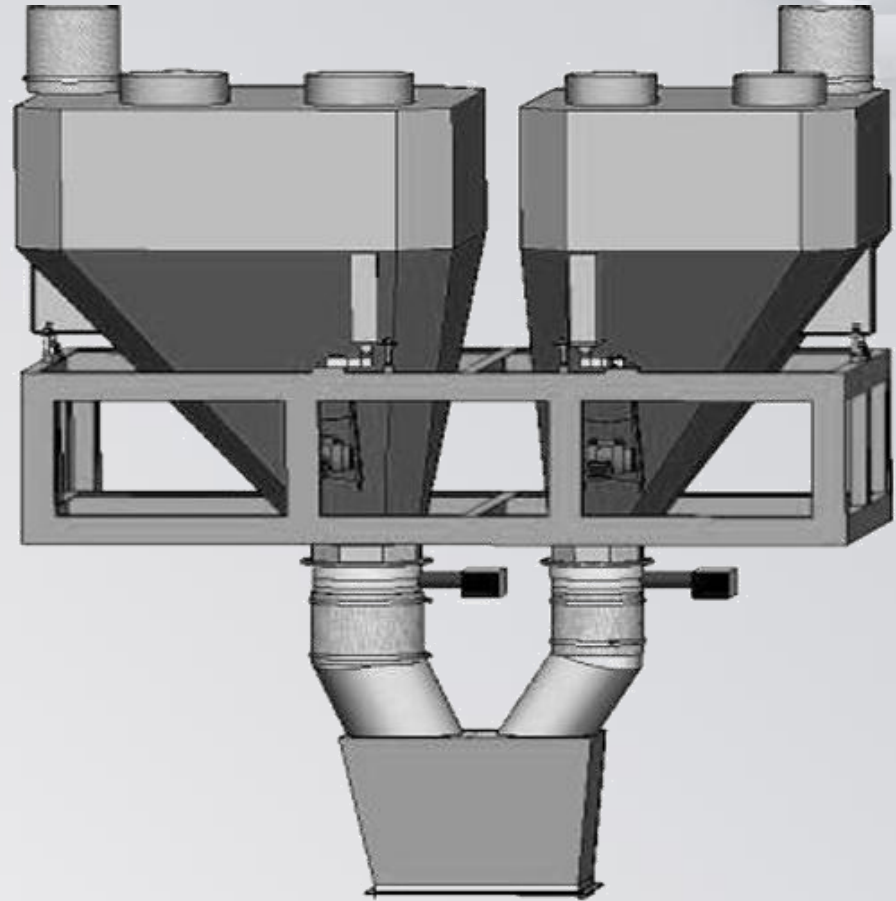

5. Water and Additive weighing



USA TOLEDO loadcell:

- Guarantee the weighing precision
- Tolerance : +/-1%



Rough and precise weighing:

- automatically add the lose and remove the extra, ensuring measurement accuracy



Admixture stainless steel weighing bin:

- against rust and corrosion, long lifetime use
- Independent admixture weigh, adding in advance and adding later are both feasible.



GUOTAI butterfly valve:

- top 1 valve brand in China, especially for liquid valve.
- both top and bottom sealing ,no leakage
- highly abrasion-resistant
- easy to fit



6. Twin-shaft compulsory mixer



SICOMA MIXER:

- ◆ Shaft ends multi seal protection and air purge seal protection to efficiently prevent leakage.
- ◆ Equipped with 24DC HDI grease pump special for concrete mixer; Self-programmed operation time, Waterproof, Dustproof, Superb performance
- ◆ Multi-pipe water sparying to ensure even water disribution.
- ◆ Heavy duty design, stable operation
- ◆ The blade can be easily adjusted in the stress and wear direction until it must be replaced.
- ◆ Equiped wear-resistant alloy blade and lining tile, the continuously mixing can up to 160,000 times
- ◆ Capacity ranged from 1cu.m to 6.0cu.m.

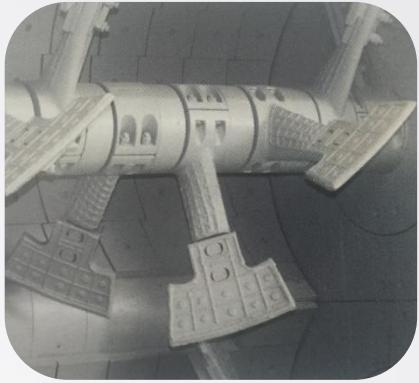

High wear-resistant alloyed mixing arm:

- high wear resistance
- strong against impact, do not break
- long operating life, low maintenance
- easy to replace



Reduction Gearbox:

- The gear reducer is made according to SICOMA's specification in Italy
- It runs at low noise and temperature.

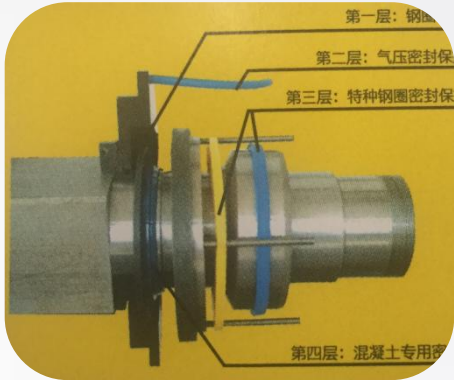

Quadruple shaft seal:

- 4 sealing blocks to avoid leakage, against the corrosion.
- shaft head bearing is made by Timken, USA, reliable and effectively extend shaft head work life



Auto Lubricating Oil pump:

- Special pumping unit design supplies grease to the four mixing shaft seal
- No more grease distributor maintenance troubles and improve working reliability

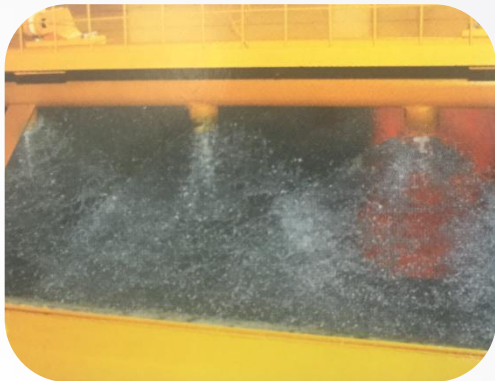

Spray water system:

- piped line inside the top cover, spray water to reduce dust out
- water and admixture can be sprayed evenly and fast, reduce the mixing time, and reduce concrete stick



Discharging valve:

- Advanced hydraulic door opening system to ensure smooth operation
- Multi adjustable stopping positions to regulate the discharge flow.
- Manual override in case of electric failure

7. Intelligent computer control system

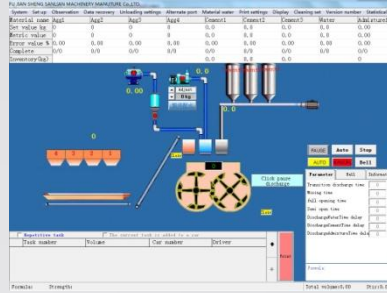

PHILIP LCD

ADVANTECH Programmable Card



ADVANTECH IPC



EPSON printer

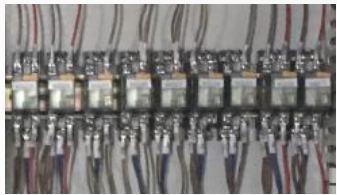

SIEMENS Relay



SIEMENS Contactor



CHIMEI weighing display controller

◆ Control room:

- ① Air conditioned, thermally insulated, lockable doors and with enough working space
- ② Equipped with complete control desk to operate the mixing plant
- ③ Three face large windows for an optimum view of site and truck tunnel.

◆ Electrical installation:

- ① All electric components, like air breaker, relay, press button and contactor are adopting SIEMENS
- ② All wires & cables are coded, easy to track and maintenance
- ③ All wiring of the individual unit are in cable tray and lead to the relative position

◆ Intelligent control system:

- ① Controled both by automatically and manually, in English.
- ② IPC +PC CARD, the control system can running fast, easy to change and upgrade function.
- ③ Color LCD screen to monitor process of the operation.
- ④ Easy to set and file the production formula list.
- ⑤ The system will find the error and show it on screen if there is a problem
- ⑥ Easy to check the records and details
- ⑦ Permission limited to change the parameter

◆ Reporting & Delivery note:

- ① DIY the delivery note and invoice
- ② Save and get report under the name of production, receipt, customer, project, etc with different time periods as daily, weekly, monthly, and annually
- ③ Easy to print the delivery note under project, trucks no. customers, and whenever.



8. Pneumatic system



TAIWAN FUSHENG
Air Compressor



0.6 m³ air
storage tank



TAIWAN EMC
F.R.L. unit



TAIWAN AIRTAC
Solenoid Valve and air
filter



0.1 m³ air storage tank special for mixing
tower use, guarantee the enough pressure



9. Environment protection system

24m² Impulse dust collector optional

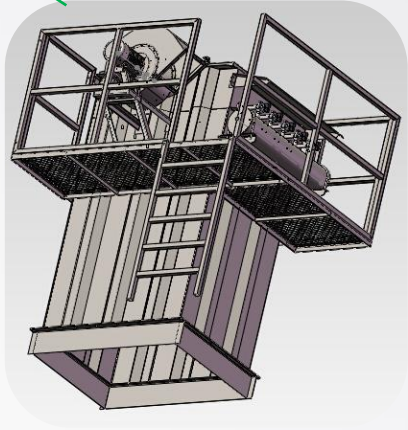

-T0.426 color steel plate External packing for mixing tower, reduce the dust and noise emission
-Sandwich board available as request



Canvas bag dust filter



Exhaust fan

10. Other parts



Galvanized bolts and nuts

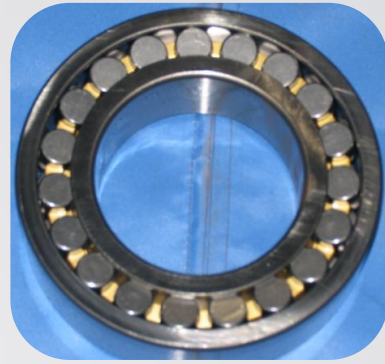

Imported bearing



Three-point monitor system



Galvanized footsteps

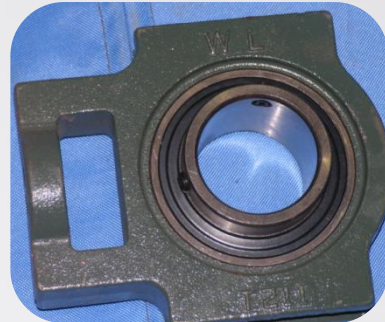

Cast-iron bearing base



Stainless steel additive pump

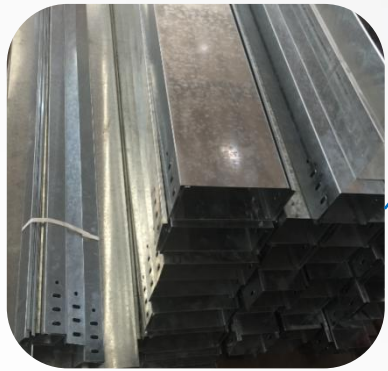

Galvanized cable tray



Heavy duty "H" beam legs



Optional for S.S additive tank with stirring system

11. Screw conveyor



**ITALY SICOMA
SCREW CONVEYOR**

- Tubular housing in standardised flanged sections with one section made to measure
- Helicoid screw flighting welded on centre pipe
- End bearing assemblies complete with self-adjusting shaft seal
- Splined shaft couplings
- Lifting eyelets on each tube section
- Standard flange-mounted electric motor
- Compact design and overall dimensions
- Quick installation due to universal inlet and outlet spouts
- Maintenance free, durable use
- Diameter available for D219,D273,D323...

10. Bolted type silo

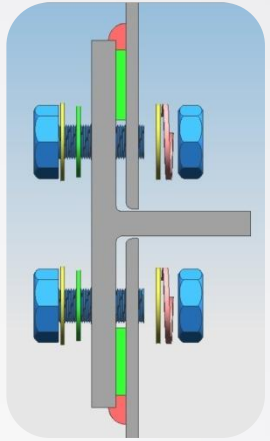

- Smart design
- self-sealing
- durable use
- Heavy duty steel sheet, optional for thickness
- Capacity ranged from 50T to 500T



- Easy to load container, low freight cost
- 3x100T silos can be loaded in 2x40HQ container
- 1x200T silo in 1x40HQ container



- Easy to erect on job site
- Coincide standard hole
- Bolts, nuts and seal strips connection
- No need skill workers

13. Silo kits



Silo top dust filter



Bottom & up level indicator



Safety valve



Aeration pad

14. overseas project



HZS60 in Bangladesh



HZS90 in Philippines



HZS120 in Mozambique

HZS180 in Mongolia



HZS100 in Zambia



HZS75 in SUBIC Bay

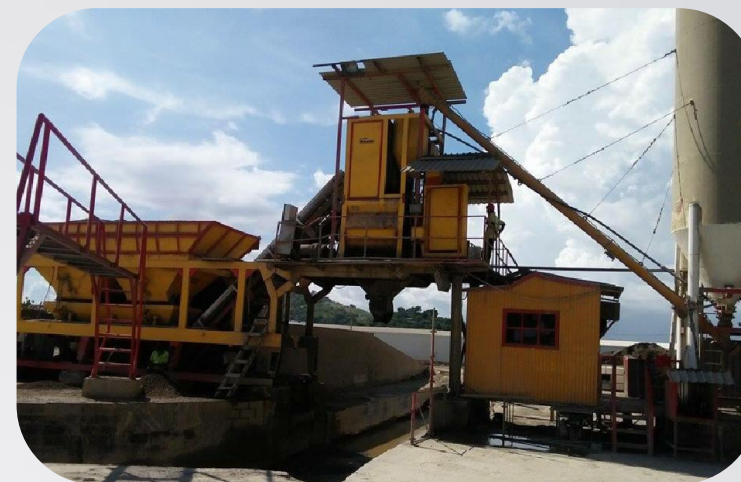

YHZS50 in Papua New Guinea

THANK YOU FOR WATCHING!!!

www.sl-machine.com

Jerry Zhuang
Sales Manager
Cell:+86-1351 5040 568
E-mail: jerry@sl-machine.com