



**blue
ascend
hydraulics**

blueascend.com

PRODUCT CATALOGUE





Blue Ascend Hydraulics is a part of ASC Industry Group and is one of the biggest players in the field with its production facility located in Germany and Turkey with a total of 91.000 m2 area and 40.000 m2 production area.

The production is focused on hydraulic gear pumps, motors and flow dividers. Both aluminium and cast iron body options are available with various shaft and flange combinations. Blue Ascend Hydraulics is serving and supplying its product to various sectors such as mobile, industry and agriculture.

Quality is a must when dealing with these sectors and the pump or motor has to complete its task flawlessly 24/7 even under extreme conditions. In order to serve the hydraulic sector properly, Blue Ascend Hydraulics R&D team has developed a product with a different production mentality that assures a longer lifetime above the standards, higher volumetric and mechanical efficiencies.

**GEAR
PUMPS**

**GEAR FLOW
DIVIDERS**

**GEAR
MOTORS**

**ORBITAL
MOTORS**

Blue Ascend Hydraulics does all the the production processes in-house such as gear production, body production, heat treatment and production of other parts used in the final product. By doing this they gain complete control over the quality and assures stability.

One of the advantages Blue Ascend Hydraulics has that puts their product in the front line is their short production and delivery times. This is assured by the modern machine parkour and advanced semi-finished product stock management.

A complete quality control management system is present at Blue Ascend Hydraulics that gives them complete traceability from the first stage such as used raw material, production process, and final test reports.

ISO 9001
BUREAU VERITAS
Certification
TR002366-1



ISO 14001
BUREAU VERITAS
Certification
TR002367-1



ISO 18001
BUREAU VERITAS
Certification
TR002368-1



blueascend.com

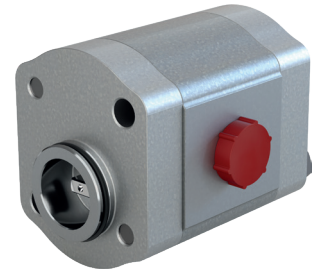
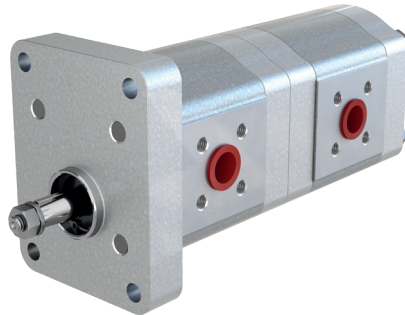
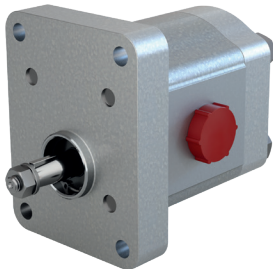

Pump Type	Displacement cm ³ /rev	Max. Pressure (bar)	Max. Speed rpm	A ±0,4	B	Inlet			Outlet		
						C	D	E	c	d	e
AP10.009.A/CAB01SN	0,9	220	4000	34,9	78,1	12	30	M6	12	30	M6
AP10.012.A/CAB01SN	1,2			35,5	79,3						
AP10.017.A/CAB01SN	1,7			36,5	81,3						
AP10.023.A/CAB01SN	2,3			37,5	83,3						
AP10.027.A/CAB01SN	2,7			38,5	85,3						
AP10.032.A/CAB01SN	3,2			39,3	86,8						
AP10.038.A/CAB01SN	3,8			40,5	89,3						
AP10.043.A/CAB01SN	4,3			41,5	91,3						
AP10.050.A/CAB01SN	5,0			43,0	94,3						
AP10.059.A/CAB01SN	5,9			44,8	97,8						
AP10.063.A/CAB01SN	6,3	210	3500	45,5	99,3						
AP10.078.A/CAB01SN	7,8			48,5	105,3						
AP10.095.A/CAB01SN	9,5			52,0	112,3						

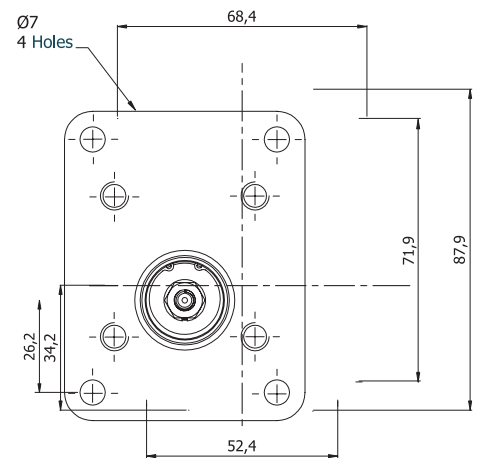
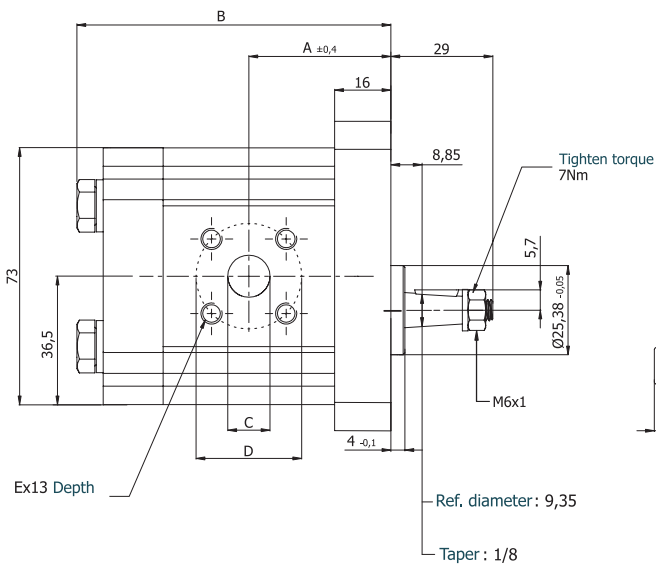

ORDERING CODE OF AP10 PUMPS

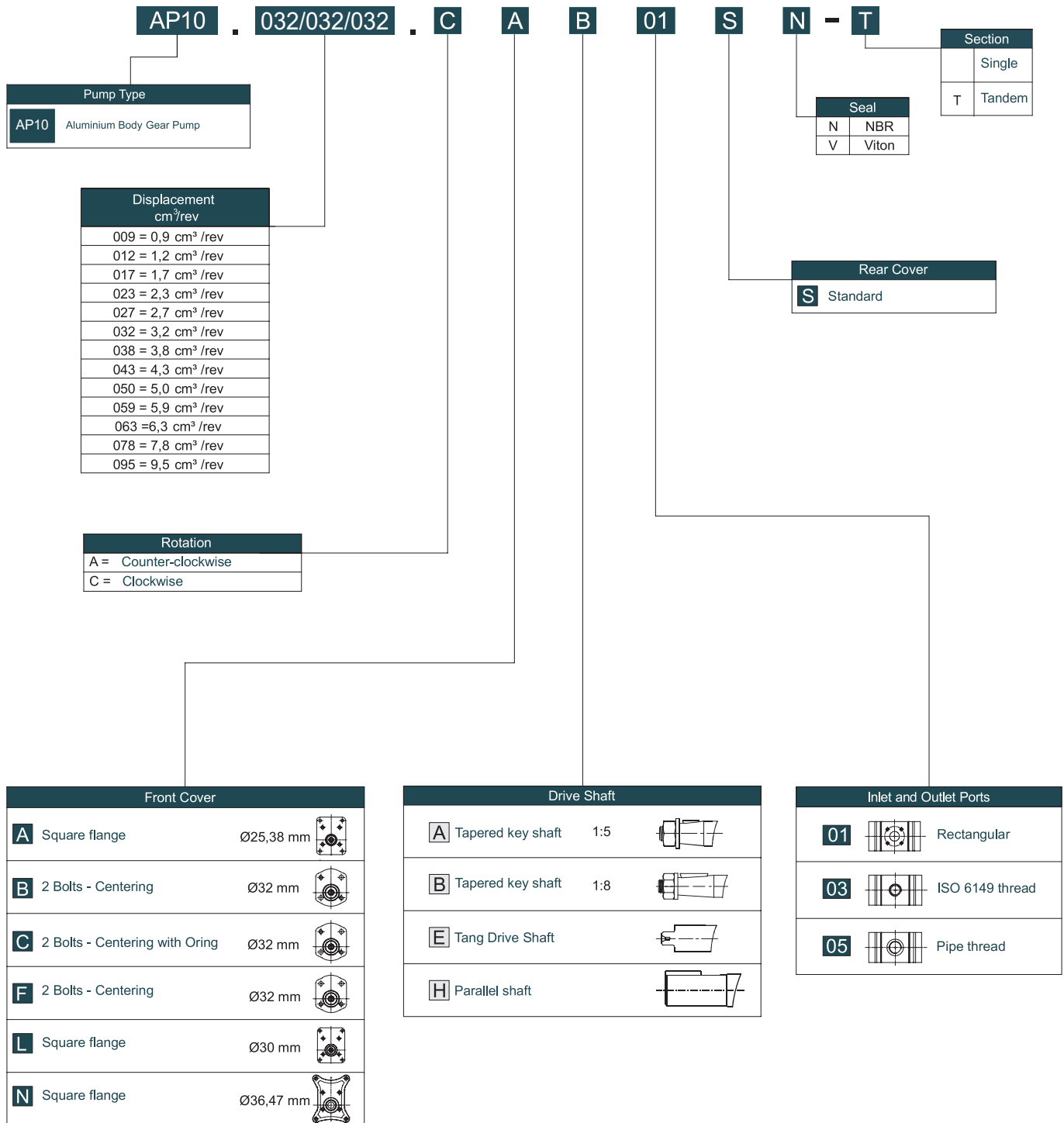

- Code Example (Single) ; AP10.032.CAB01SN

- Code Example (Tandem) ; AP10.032/032/032.CAB01SN-T

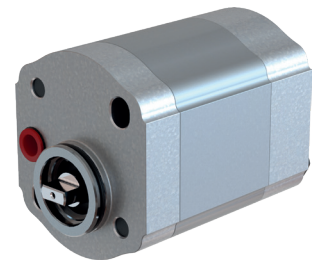
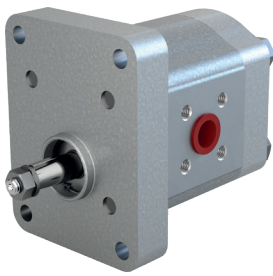

Pump Type	Displacement cm ³ /rev	Max. Pressure (bar)	Max. Speed (rpm)	Min. Speed (rpm)	A ±0,4	B	Inlet			Outlet		
							C	D	E	c	d	e
APH10.009.A/CCE01SN	0,9	220	4000	650	34,9	78,1	12	30	N6x1	12	30	N6x1
APH10.012.A/CCE01SN	1,2				35,5	79,3						
APH10.017.A/CCE01SN	1,7				36,5	81,3						
APH10.023.A/CCE01SN	2,3				37,5	83,3						
APH10.027.A/CCE01SN	2,7				38,5	85,3						
APH10.032.A/CCE01SN	3,2				39,3	86,8						
APH10.038.A/CCE01SN	3,8				40,5	89,3						
APH10.043.A/CCE01SN	4,3				41,5	91,3						
APH10.050.A/CCE01SN	5,0				43,0	94,3						
APH10.059.A/CCE01SN	5,9				44,8	97,8						
APH10.063.A/CCE01SN	6,3	210	3500	650	45,5	99,3	12	30	N6x1	12	30	N6x1
APH10.078.A/CCE01SN	7,8				48,5	105,3						
APH10.095.A/CCE01SN	9,5				200	52,0						

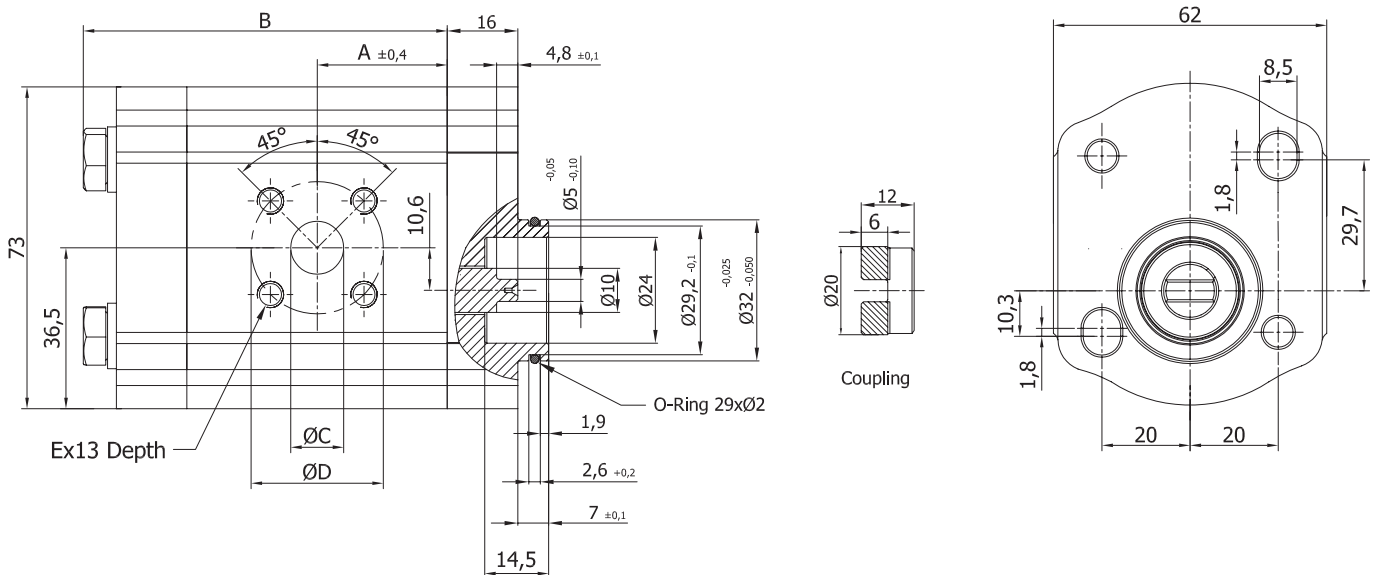

ALUMINIUM BODY EXTERNAL HELICAL GEAR PUMPS



ORDERING CODE OF APH10 PUMPS

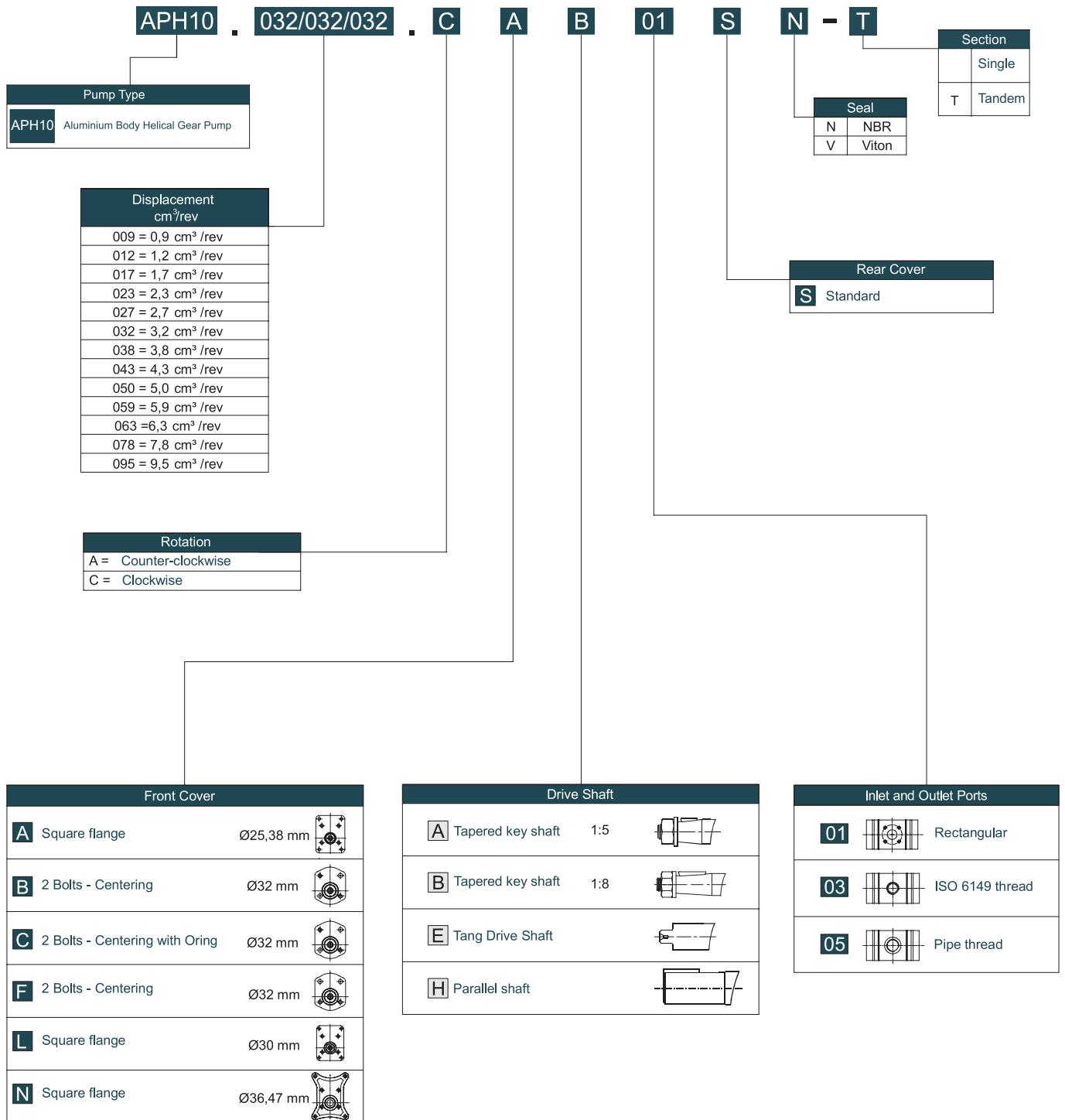

- Code Example (Single) ; APH10.032.CAB01SN - Code Example (Tandem) ; APH10.032/032/032.CAB01SN-T



Pump Type	Displacement cm ³ /rev	Max. Pressure (bar)	Max. Speed rpm	A ±0,4	B	Inlet			Outlet			
						C	D	E	c	d	e	
AP20.040.A/CAB02SN	3,9	250	3500	42,2	85,3	12	30,2	M6	12	30,2	M6	
AP20.060.A/CAB02SN	5,9			43,8	88,4	13,5			M6			12
AP20.080.A/CAB02SN	8,0			45,4	91,6							
AP20.095.A/CAB02SN	9,4			46,5	93,9							
AP20.115.A/CAB02SN	11,4		3000	48,2	97,0	20	40	M8	13,5			
AP20.140.A/CAB02SN	13,9			50,0	101,0							
AP20.160.A/CAB02SN	16,0			51,7	104,1							
AP20.190.A/CAB02SN	19,2			60,2	121,1							
AP20.220.A/CAB02SN	21,9	210	2500	62,3	125,5	20	40	M8	13,5	30,2	M6	
AP20.250.A/CAB02SN	24,8	190		64,8	130,4							
AP20.280.A/CAB02SN	27,9	170	2000	67,0	134,9	20	40	M8	13,5	30,2	M6	
AP20.320.A/CAB02SN	32,0	160		70,0	141,0							
AP20.340.A/CAB02SN	34,0	150	1750	71,5	144,5	20	40	M8	13,5	30,2	M6	
AP20.380.A/CAB02SN	38,0	140		74,8	150,5							
AP20.400.A/CAB02SN	40,0	130	76,5	154,0	20	40	M8	13,5	30,2	M6		

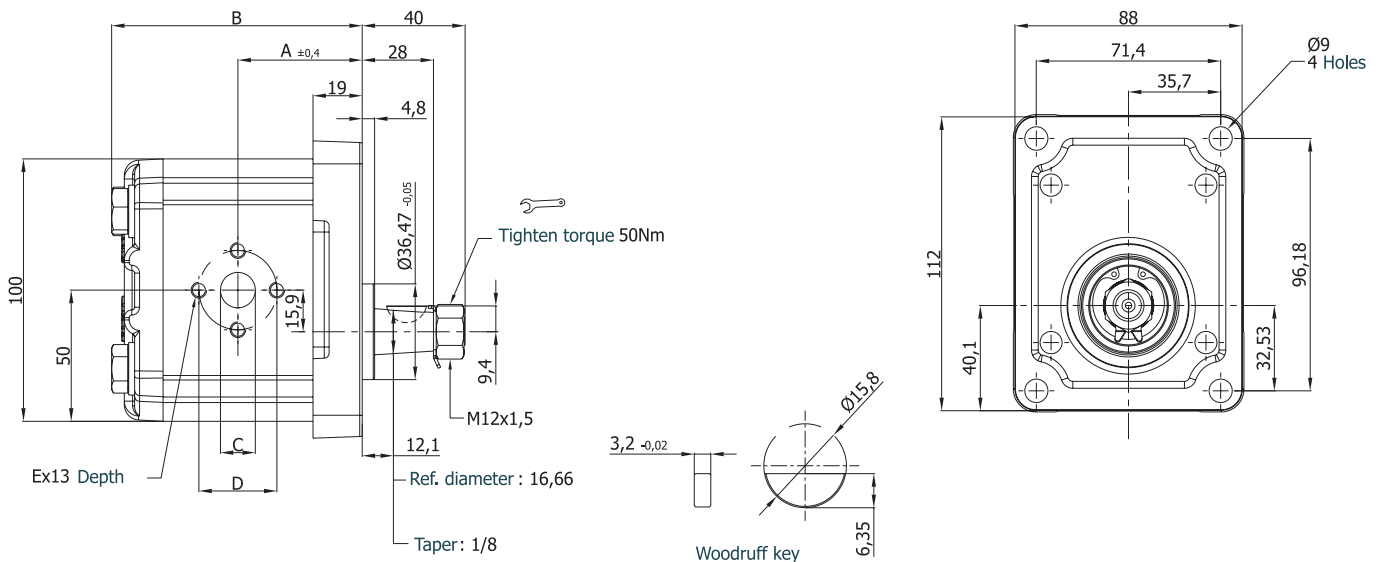

ORDERING CODE OF GROUP 20 PUMPS

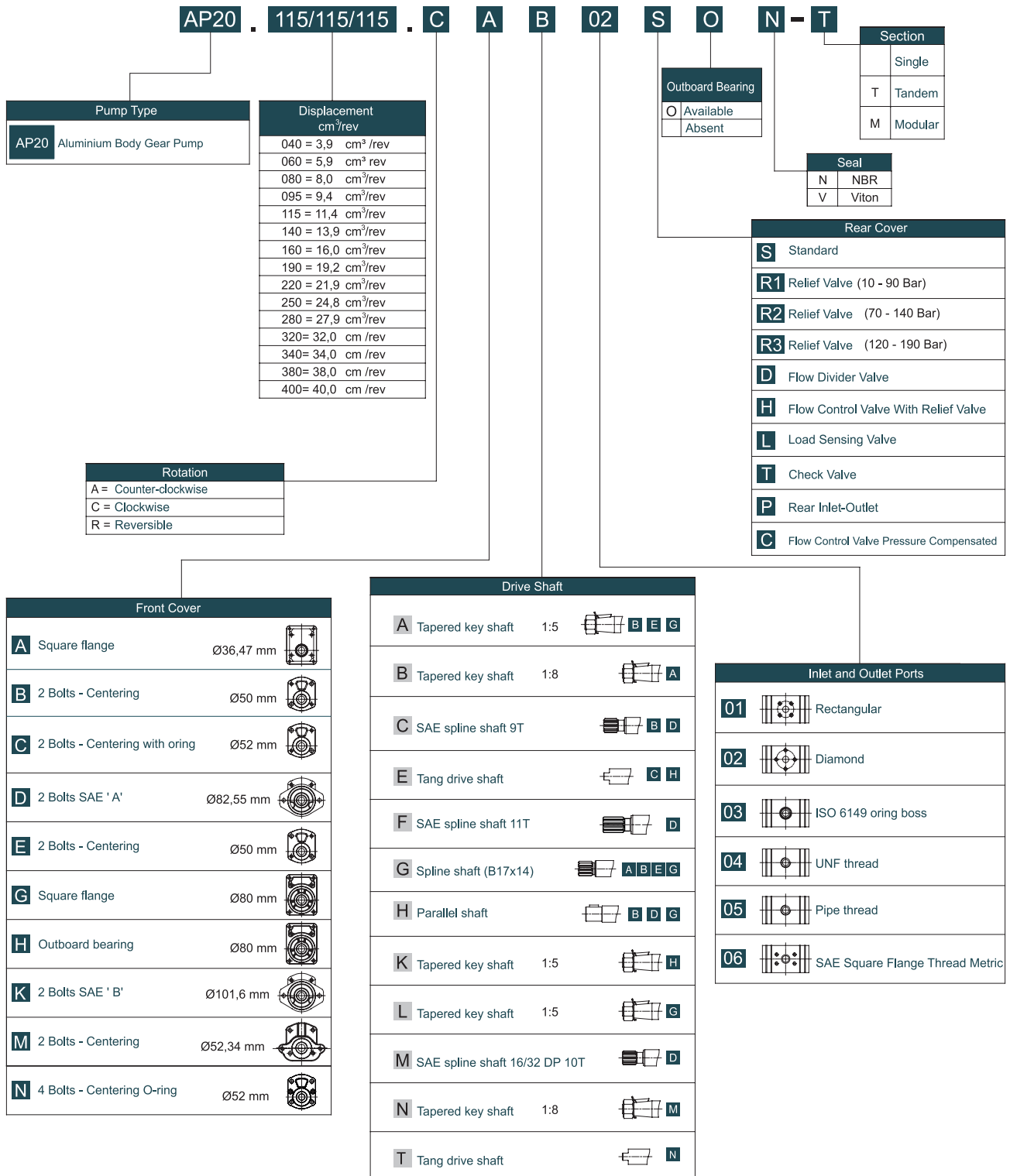

- Code Example (Single) ; AP20.115.CAB02SN

- Code Example (Tandem) ; AP20.115/115/115.CAB02SN-T

- Code Example (Modular) ; AP20.115/115/115.CAB02SN-M

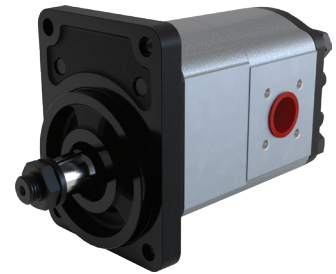
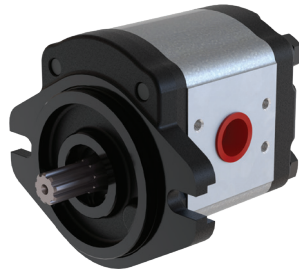

Pump Type	Displacement cm ³ /rev	Max. Pressure (bar)	Max. Speed (rpm)	A ±0,4	B	Inlet			Outlet		
						C	D	E	c	d	e
APH20.040.A/CBG01SN	3,9	250	3500	41,6	84,7	12	40	M6	12	35	M6
APH20.060.A/CBG01SN	5,9			43,2	87,8	13,5			13,5		
APH20.080.A/CBG01SN	8,0			44,8	91,0	20			15		
APH20.095.A/CBG01SN	9,4			45,9	93,3						
APH20.115.A/CBG01SN	11,4		47,6	96,4	2500	20			15		
APH20.140.A/CBG01SN	13,9		49,4	100,4							
APH20.160.A/CBG01SN	16,0		51,1	103,5							
APH20.190.A/CBG01SN	19,2		59,6	120,5							
APH20.220.A/CBG01SN	21,9	210	2500	61,7	124,9	20	15	20	40		
APH20.250.A/CBG01SN	24,8	190		64,2	129,8						
APH20.280.A/CBG01SN	27,9	170	2200	66,4	134,3	20	40				

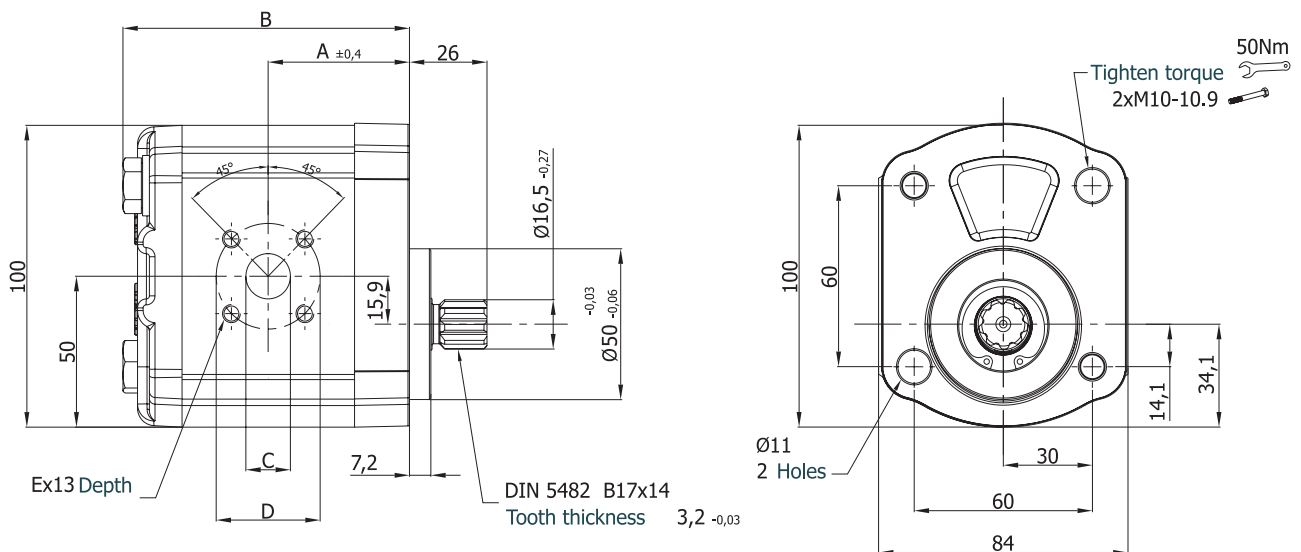

ALUMINIUM BODY EXTERNAL HELICAL GEAR PUMPS



ORDERING CODE OF GROUP 20 PUMPS

APH20 . 115/115/115 . C A B 02 S O N - T

Pump Type	Displacement cm ³ /rev
APH20 Aluminium Body Helical Gear Pump	040 = 3,9 cm ³ /rev
	060 = 5,9 cm ³ /rev
	080 = 8,0 cm ³ /rev
	095 = 9,4 cm ³ /rev
	115 = 11,4 cm ³ /rev
	140 = 13,9 cm ³ /rev
	160 = 16,0 cm ³ /rev
	190 = 19,2 cm ³ /rev
	220 = 21,9 cm ³ /rev
	250 = 24,8 cm ³ /rev
	280 = 27,9 cm ³ /rev

Rotation
A = Counter-clockwise
C = Clockwise
R = Reversible

Outboard Bearing
O Available
Absent

Section
Single
T Tandem
M Modular

Seal
N NBR
V Viton

Rear Cover
S Standard
R1 Relief Valve (10 - 90 Bar)
R2 Relief Valve (70 - 140 Bar)
R3 Relief Valve (120 - 190 Bar)
D Flow Divider Valve
H Flow Control Valve With Relief Valve
L Load Sensing Valve
T Check Valve
P Rear Inlet-Outlet
C Flow Control Valve Pressure Compensated

Front Cover
A Square flange Ø36,47 mm
B 2 Bolts - Centering Ø50 mm
C 2 Bolts - Centering with oring Ø52 mm
D 2 Bolts SAE 'A' Ø82,55 mm
E 2 Bolts - Centering Ø50 mm
G Square flange Ø80 mm
H Outboard bearing Ø80 mm
K 2 Bolts SAE 'B' Ø101,6 mm
M 2 Bolts - Centering Ø52,34 mm
N 4 Bolts - Centering O-ring Ø52 mm

Drive Shaft
A Tapered key shaft 1:5 B E G
B Tapered key shaft 1:8 A
C SAE spline shaft 9T B D
E Tang drive shaft C H
F SAE spline shaft 11T D
G Spline shaft (B17x14) A B E G
H Parallel shaft B D G
K Tapered key shaft 1:5 H
L Tapered key shaft 1:5 G
M SAE spline shaft 16/32 DP 10T D
N Tapered key shaft 1:8 M
T Tang drive shaft N

Inlet and Outlet Ports
01 Rectangular
02 Diamond
03 ISO 6149 oring boss
04 UNF thread
05 Pipe thread
06 SAE Square Flange Thread Metric

Code Example (Single) APH20.115.CAB02SN

Code Example (Tandem) ; APH20.115/115/115.CAB02SN-T

Code Example (Modular) ; APH20.115/115/115.CAB02SN-M



Pump Type	Displacement cm ³ /rev	Max. Pressure (bar)	Max. Speed rpm	A ±0,4	B	Inlet		Outlet	
						C	D	c	d
DKP20.040.A/CDC04SN	3,9	280	3500	42,2	85,3	9/16-18 UNF	13	9/16-18 UNF	13
DKP20.060.A/CDC04SN	5,9			43,8	88,4				
DKP20.080.A/CDC04SN	8,0			45,4	91,6	7/8-14 UNF	16		
DKP20.095.A/CDC04SN	9,4			46,5	93,9				
DKP20.115.A/CDC04SN	11,4		3000	48,2	97,0	1 1/16-12 UNF	19	7/8-14 UNF	16
DKP20.140.A/CDC04SN	13,9			50,0	101,0				
DKP20.160.A/CDC04SN	16,0			51,7	104,1				
DKP20.190.A/CDC04SN	19,2			60,2	121,1				
DKP20.220.A/CDC04SN	21,9	240	2500	62,3	125,5				
DKP20.250.A/CDC04SN	24,8	220		64,8	130,4				
DKP20.280.A/CDC04SN	27,9	200	2200	67,0	134,9				

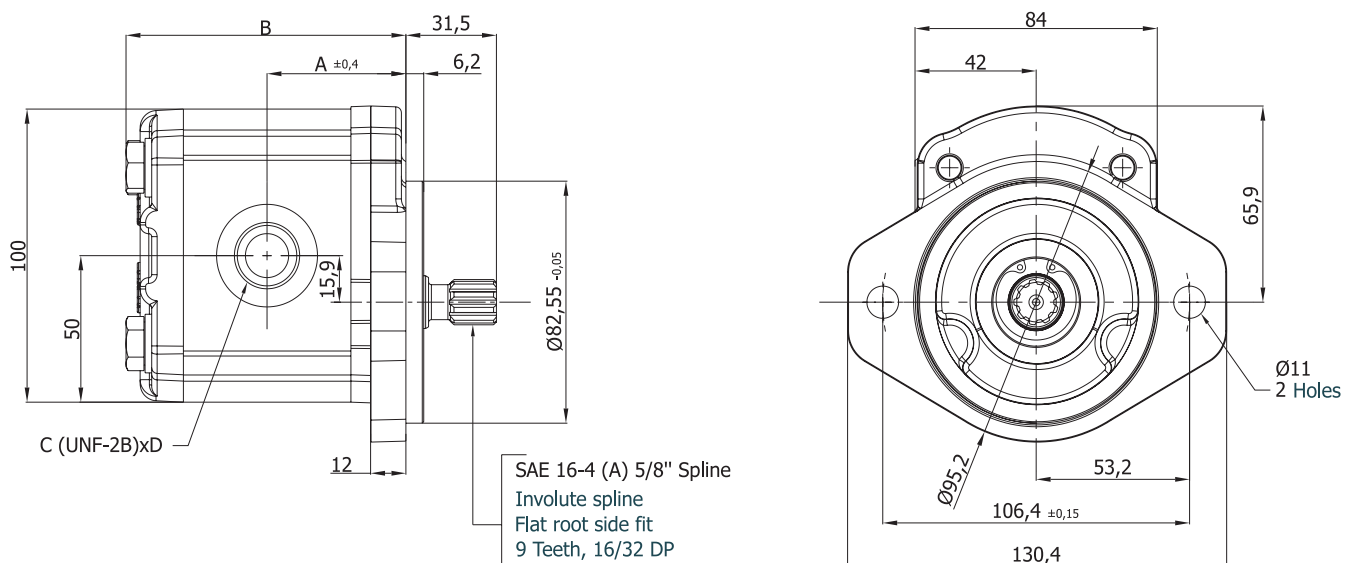

CAST IRON BODY EXTERNAL GEAR PUMPS

DKP20

ORDERING CODE OF GROUP 20 PUMPS

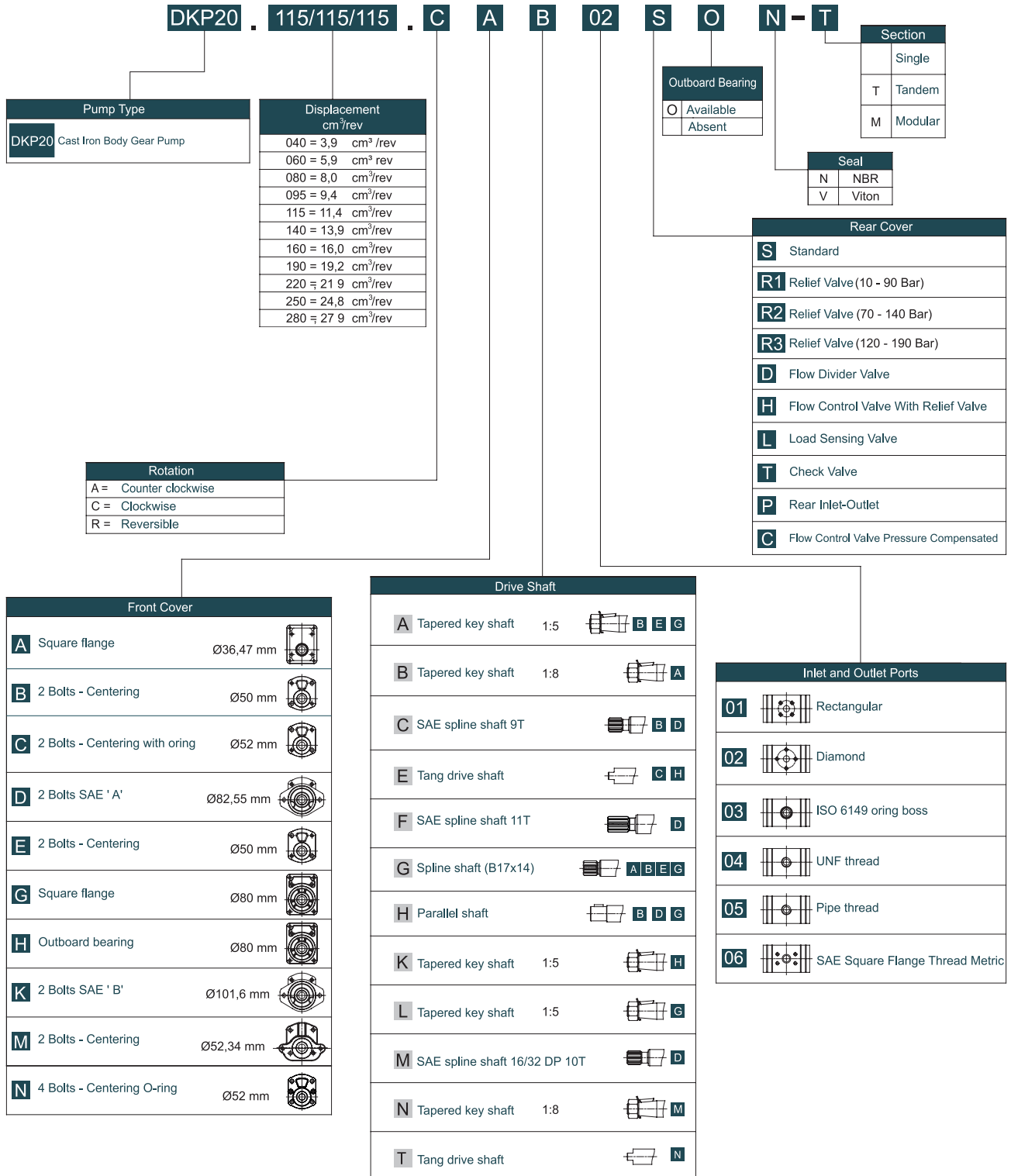

Code Example (Single) ; DKP20.115.CAB02SN

Code Example (Tandem) ; DKP20.115/115/115.CAB02SN-T

Code Example (Modular) ; DKP20.115/115/115.CAB02SN-M



Pump Type	Displacement cm ³ /rev	Max. Pressure (bar)	Max. Speed rpm	A _{±0,4}	B	Inlet			Outlet		
						C	D	E	c	d	e
DPH20.040.A/CCE01SN	3,9	280	3500	41,6	84,7	12,0	40	M6	12	35	M6
DPH20.060.A/CCE01SN	5,9			13,5	13,5						
DPH20.080.A/CCE01SN	8,0			13,5	13,5						
DPH20.095.A/CCE01SN	9,4			13,5	13,5						
DPH20.115.A/CCE01SN	11,4			13,5	13,5						
DPH20.140.A/CCE01SN	13,9			13,5	13,5						
DPH20.160.A/CCE01SN	16,0			13,5	13,5						
DPH20.190.A/CCE01SN	19,2			13,5	13,5						
DPH20.220.A/CCE01SN	21,9	240	2500	61,7	124,9	20,0	40	M6	15	35	M6
DPH20.250.A/CCE01SN	24,8	220		64,2	129,8						
DPH20.280.A/CCE01SN	27,9	200	2200	66,4	134,3	20,0	40	M6	20	40	M6

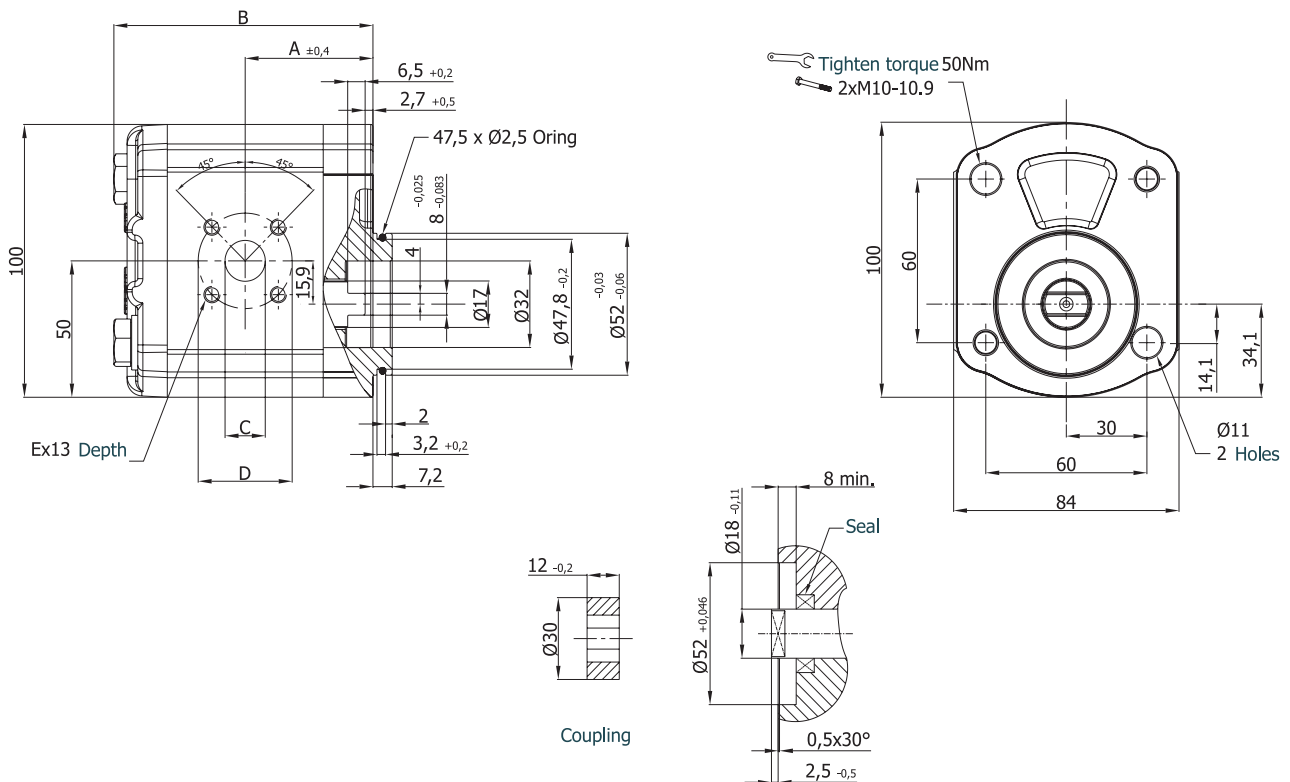

CAST IRON BODY EXTERNAL HELICAL GEAR PUMPS

DPH20

ORDERING CODE OF GROUP 20 PUMPS

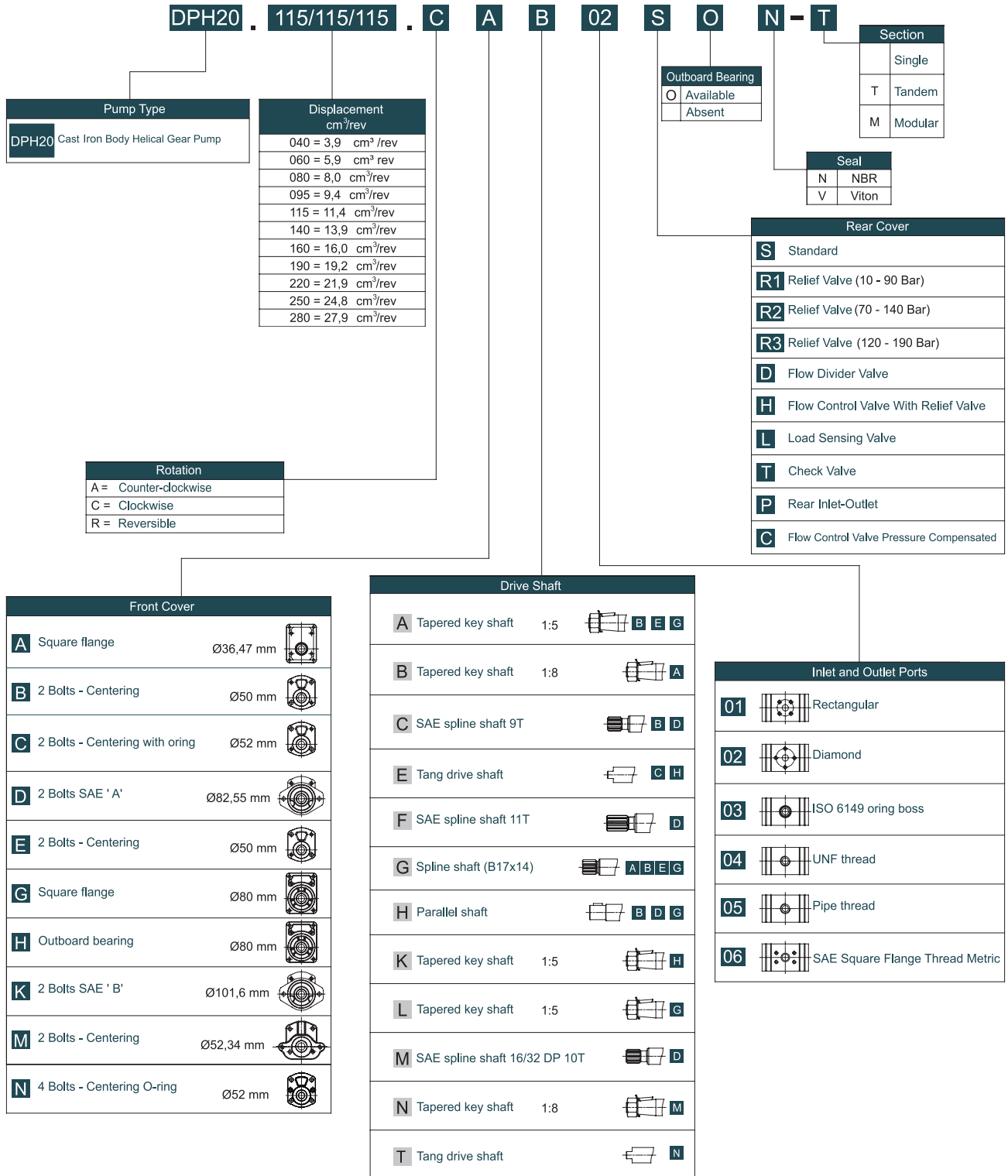

Code Example (Single) ;DPH20.115.CAB02SN

Code Example (Tandem) ;DPH20.115/115/115.CAB02SN-T

Code Example (Modular) ;DPH20.115/115/115.CAB02SN-M

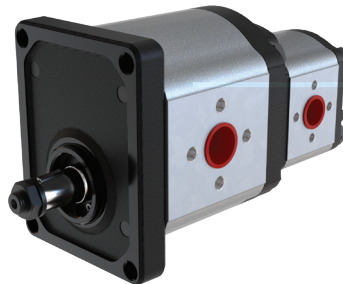
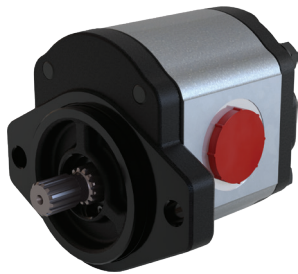

Pump Type	Displacement cm ³ /rev	Max. Pressure (bar)	Max. Speed rpm	A ±0,4	B	Inlet			Outlet		
						C	D	E	c	d	e
AP30.170.A/CAB02SN	17,0	250	3000	59,5	124,1	27	51	M10x19	19	40	M8x16
AP30.220.A/CAB02SN	22,0			61,5	128,1						
AP30.270.A/CAB02SN	27,0			63,0	131,1						
AP30.320.A/CAB02SN	32,0	240		64,5	134,1						
AP30.340.A/CAB02SN	34,0			65,0	135,1						
AP30.380.A/CAB02SN	38,0			66,5	138,1						
AP30.430.A/CAB02SN	43,0	230	2500	68,0	141,1	33	62	M12x19	27	51	M10x19
AP30.470.A/CAB02SN	47,0			69,5	144,1						
AP30.510.A/CAB02SN	51,0			70,5	146,1						
AP30.560.A/CAB02SN	56,0	200		71,5	148,1						
AP30.610.A/CAB02SN	61,0	180		74,0	153,1						
AP30.730.A/CAB02SN	73,0	170		77,0	160,1						
AP30.820.A/CAB02SN	82,0	160	2000	80,0	166,1	33	62	M12x19	27	51	M10x19
AP30.900.A/CAB02SN	90,0	150		83,0	172,1						
AP30.1000.A/CAB02SN	100,0	140		86,0	178,1						

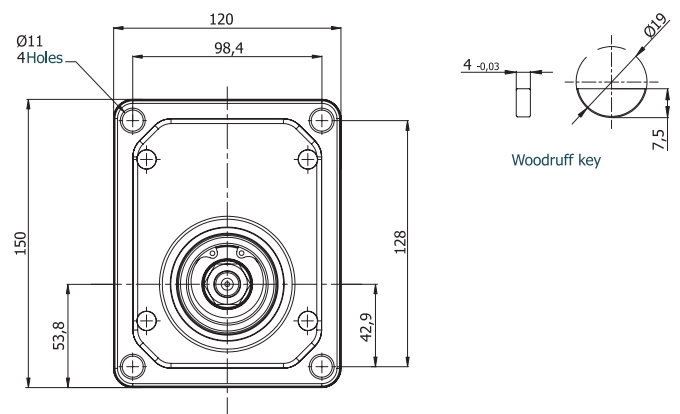
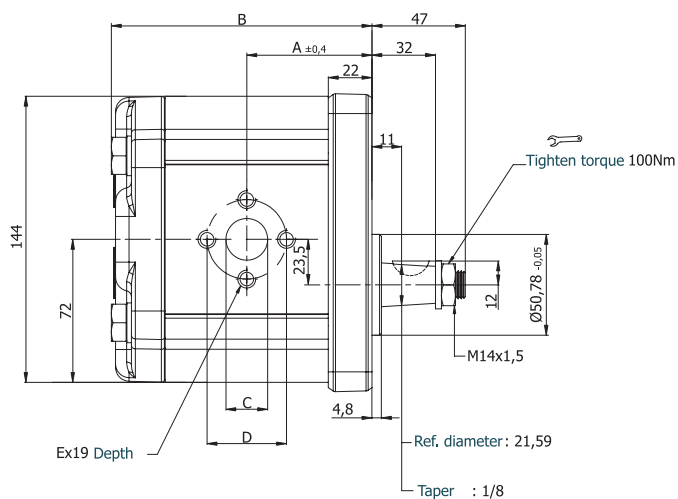

ORDERING CODE OF GROUP 30 PUMPS

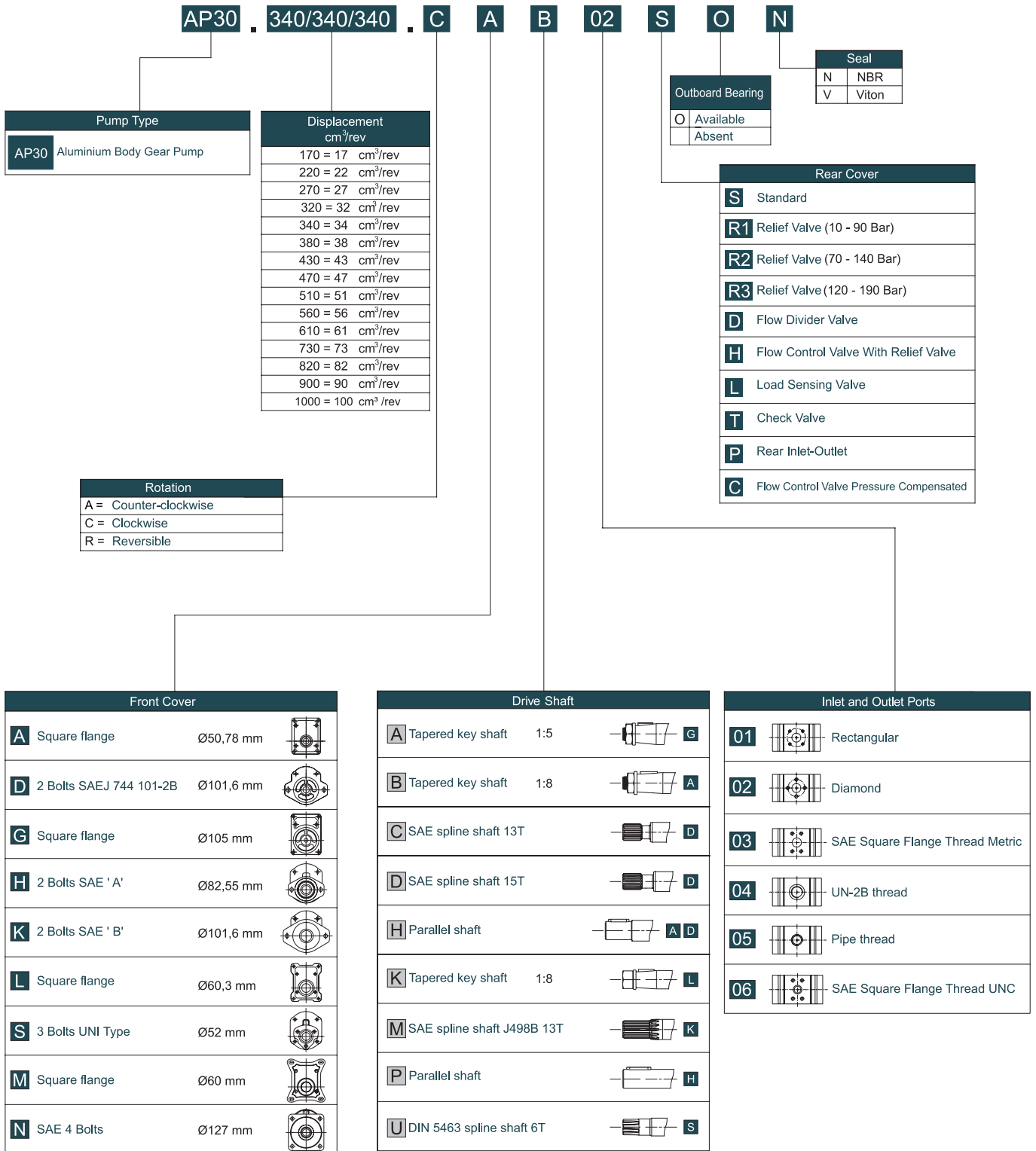

Code Example (Single) ; AP30.340.CAB02SN

Code Example (Tandem) ; AP30.340/340/340.CAB02SN

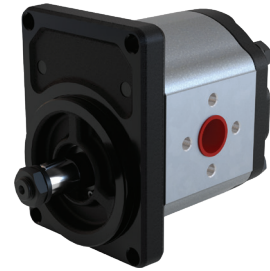
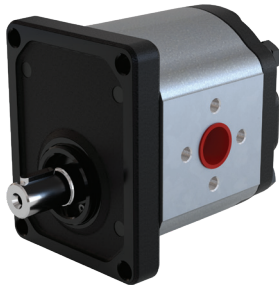

Pump Type	Displacement cm ³ /rev	Max. Pressure (bar)	Max. Speed rpm	A ±0,4	B	Inlet			Outlet		
						C	D	E	c	d	e
APH30.190.A/CAH02SN	19,0	230	3000	63,0	130,8	26	51	M10x19	20	40	M8x16
APH30.220.A/CAH02SN	22,0			64,0	133,8						
APH30.250.A/CAH02SN	25,0			66,0	136,8						
APH30.280.A/CAH02SN	28,0			67,0	139,8						
APH30.320.A/CAH02SN	32,0	210	2750	69,0	142,8						
APH30.350.A/CAH02SN	35,0			70,0	145,8						
APH30.380.A/CAH02SN	38,0			72,0	148,8						
APH30.420.A/CAH02SN	42,0			74,0	152,8						
APH30.450.A/CAH02SN	45,0	200	2500	75,0	155,8						
APH30.510.A/CAH02SN	51,0		2250	78,0	160,8						
APH30.560.A/CAH02SN	56,0	180	2000	80,0	165,8						
APH30.610.A/CAH02SN	61,0	170	1750	83,0	171,0						

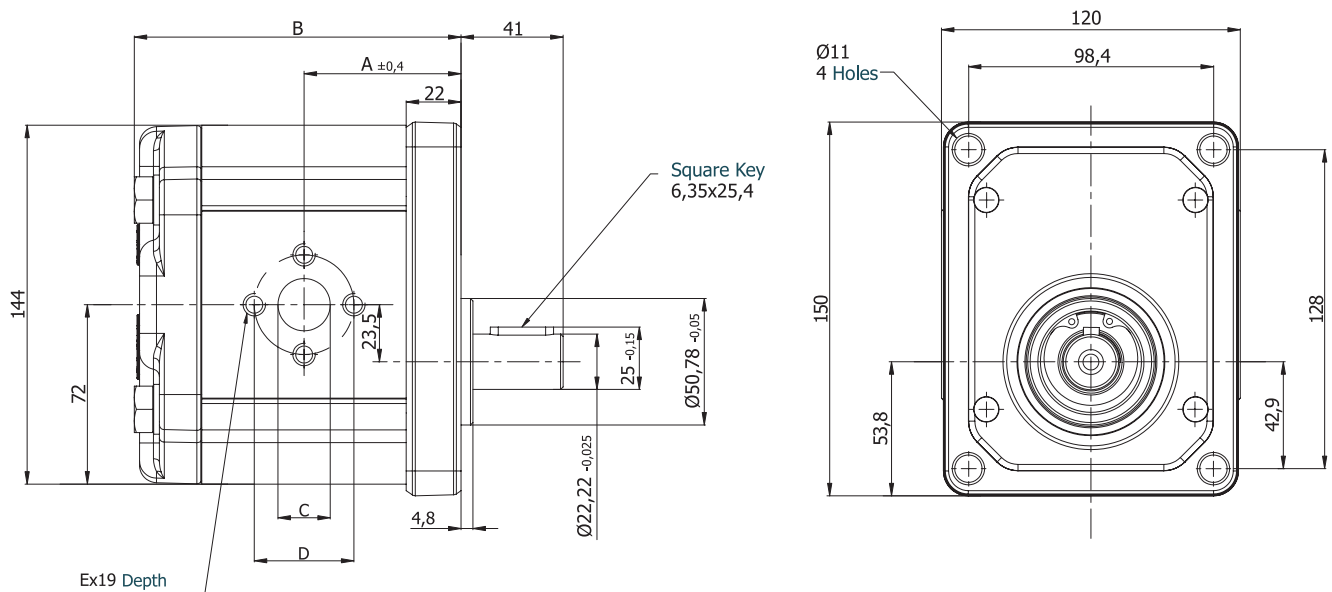

ALUMINIUM BODY EXTERNAL HELICAL GEAR PUMPS APH30

ORDERING CODE OF GROUP 30 PUMPS

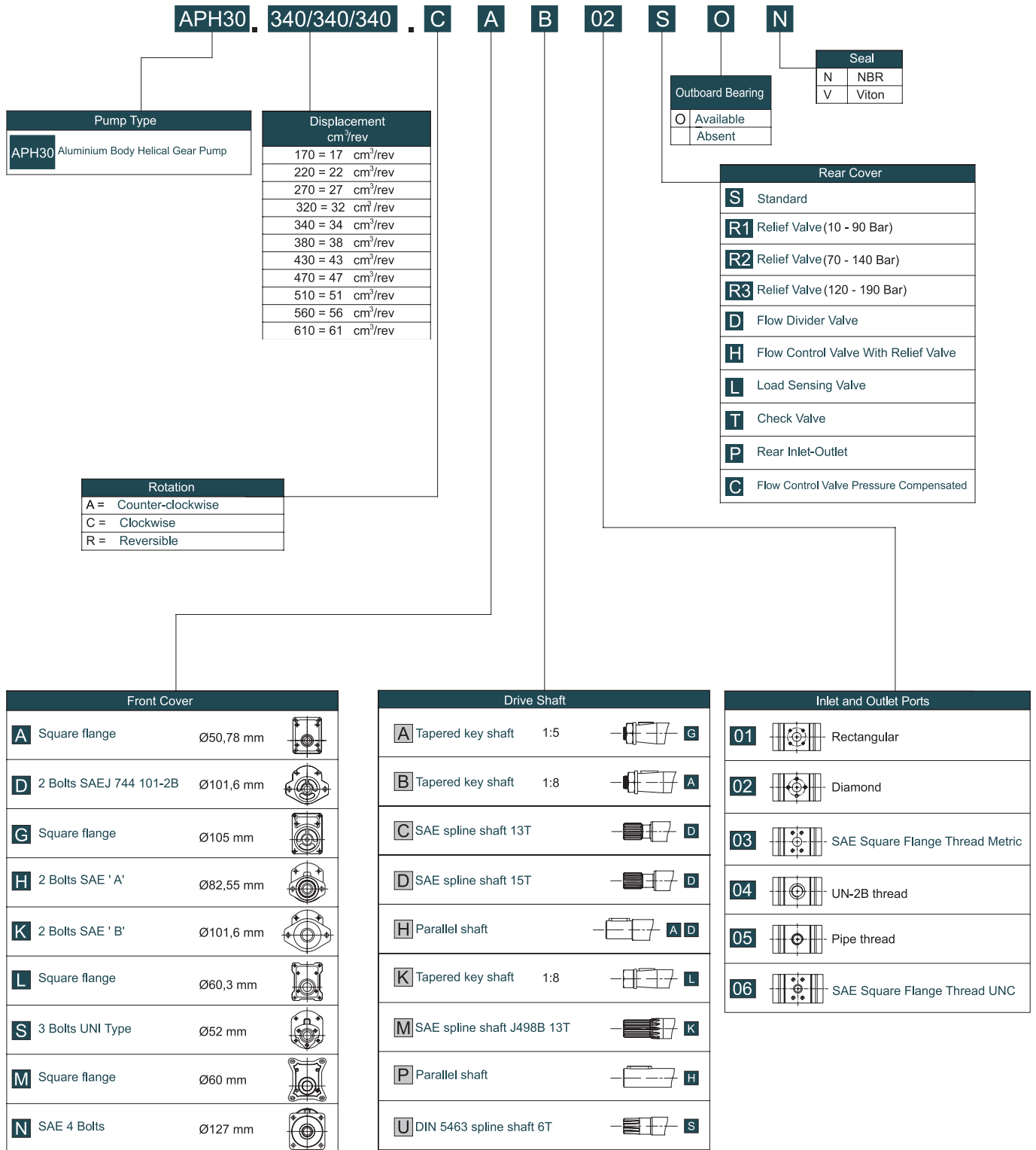

Code Example (Single) ; APH30.340.CAB02SN

Code Example (Tandem) ; APH30.340/340/340.CAB02SN



Pump Type	Displacement cm ³ /rev	Max. Pressure (bar)	Max. Speed rpm	A ±0,4	B	Inlet			Outlet		
						C	D	E	c	d	e
DKP30.170.A/CDC04SN	17,0	280	3000	59,5	124,1	30,5	49	1 5/16"-12 UNF-2B	24,8	42	1 1/16"-12 UNF-2B
DKP30.220.A/CDC04SN	22,0			61,5	128,1						
DKP30.270.A/CDC04SN	27,0			63,0	131,1						
DKP30.320.A/CDC04SN	32,0			64,5	134,1						
DKP30.340.A/CDC04SN	34,0			65,0	135,1						
DKP30.380.A/CDC04SN	38,0			66,5	138,1						
DKP30.430.A/CDC04SN	43,0	250	2500	68,0	141,1	39,1	58	1 5/8"-12 UNF-2B	30,5	49	1 5/16"-12 UNF-2B
DKP30.470.A/CDC04SN	47,0			69,5	144,1						
DKP30.510.A/CDC04SN	51,0			70,5	146,1						
DKP30.560.A/CDC04SN	56,0			71,5	148,1						
DKP30.610.A/CDC04SN	61,0	220	2000	74,0	153,1	45	65	1 7/8"-12 UNF-2B	39,1	58	1 5/8"-12 UNF-2B
DKP30.730.A/CDC04SN	73,0	200		77,0	160,1						
DKP30.820.A/CDC04SN	82,0	190		80,0	166,1						
DKP30.900.A/CDC04SN	90,0	180		83,0	172,1						
DKP30.1000.A/CDC04SN	100,0			86,0	178,1						

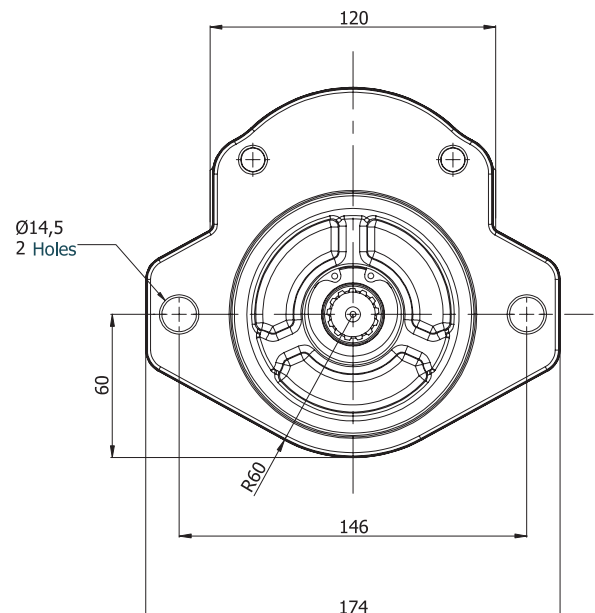
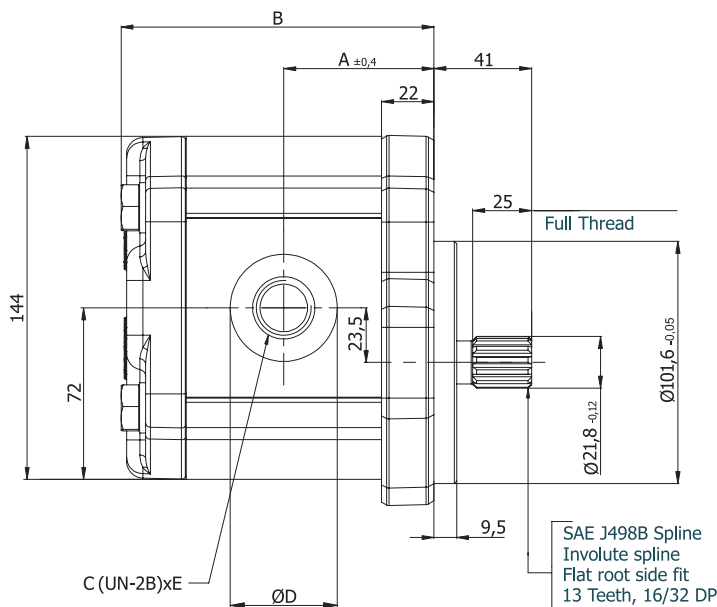

CAST IRON BODY EXTERNAL GEAR PUMPS

ORDERING CODE OF GROUP 30 PUMPS

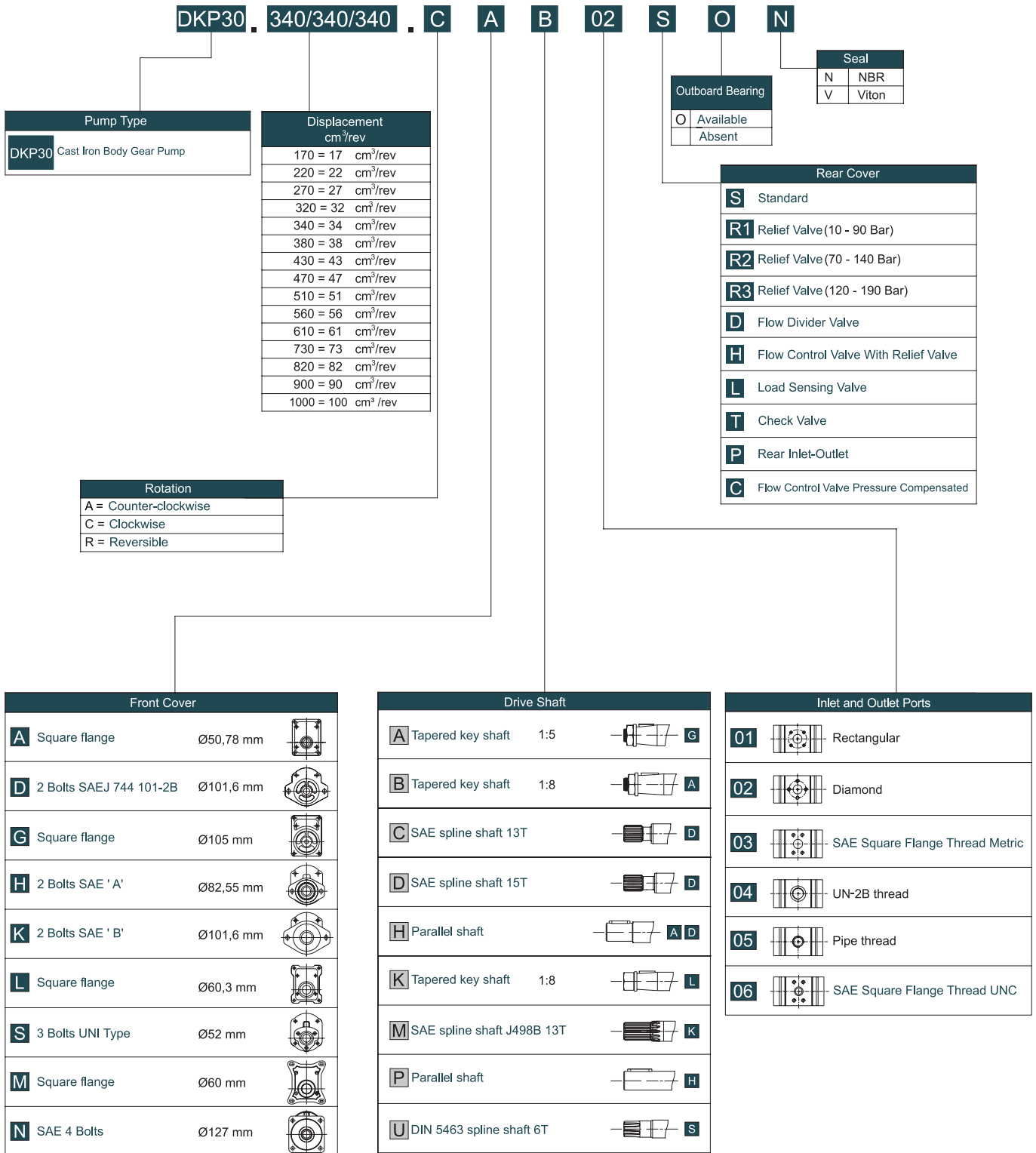

Code Example (Single) ; DKP30.340.CAB02SN

Code Example (Tandem) ; DKP30.340/340/340.CAB02SN

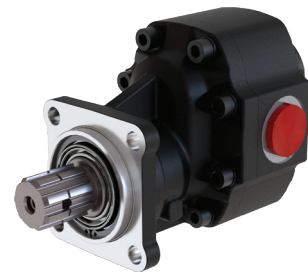

Pump Type	Displacement cm ³ /rev	Max. Pressure (bar)	Max. Speed rpm	A ±0,4	B	Inlet	Outlet
						C	c
GP30.017.CRM1N	17,2	300	3000	119,0	172,6	G 1/2"	G 1/2"
GP30.017.ARM1N							
GP30.027.CRM1N	27,1	290	2750	122,2	179,0	G 3/4"	G 3/4"
GP30.027.ARM1N							
GP30.034.CRM1N	34,4	280	2500	124,5	183,6	G 1"	G 1"
GP30.034.ARM1N							
GP30.043.CRM1N	42,9	270	2000	127,4	189,4	G 1-1/4"	G 1-1/4"
GP30.043.ARM1N							
GP30.051.CRM1N	51,2	240	1750	129,5	193,5	G 1-1/4"	G 1-1/4"
GP30.051.ARM1N							
GP30.061.CRM1N	60,7	220	1750	133,2	201,0	G 1-1/4"	G 1-1/4"
GP30.061.ARM1N							
GP30.073.CRM1N	73,0	200	1750	137,1	208,7	G 1-1/4"	G 1-1/4"
GP30.073.ARM1N							
GP30.082.CRM1N	81,4	190	1750	140,0	214,5	G 1-1/4"	G 1-1/4"
GP30.082.ARM1N							
GP30.100.CRM1N	99,7	180	1750	145,8	226,1	G 1-1/4"	G 1-1/4"
GP30.100.ARM1N							

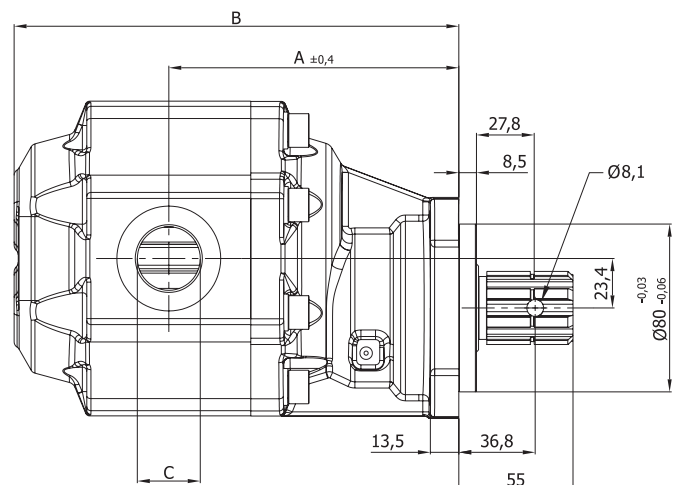
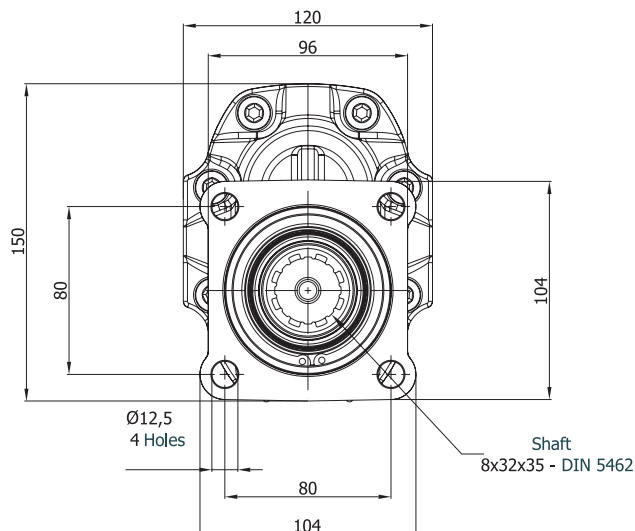

ORDERING CODE OF GP30 PUMPS

GP30 . 082/082 . C S T1 T N

GP30 Side Inlet-Outlet

Seals	
N	NBR
V	VITON

Internal Drain Port	
T	Available
	Absent

Shaft Type	
T1	Spline Shaft 6x24x25 DIN 5463
M1	Spline Shaft 8x32x35 DIN 5462
S2	Spline Shaft B6x30x35 DIN 9611 SAE 1 3/8"
S	Parallel Shaft A8x7x32 DIN 6885
B1	Tapered key shaft 1:8

Displacement cm ³ /rev
017 = 17,2 cm ³ / rev
027 = 27,1 cm ³ / rev
034 = 34,4 cm ³ / rev
043 = 42,9 cm ³ / rev
051 = 51,2 cm ³ / rev
061 = 60,7 cm ³ / rev
073 = 73,0 cm ³ / rev
082 = 81,4 cm ³ / rev
100 = 99,7 cm ³ / rev

Rotation	
A	Counter-clockwise
C	Clockwise
R	Reversible

Front Cover	
S	3 Holes Ø73
R	4 Holes Ø80
P	6 Holes Ø52
D	2 Holes Ø82,5
A	Square Flange Ø50,78

Code Example (Single) ; GP30.082.CST1N

Code Example (Tandem) ; GP30.082/082.CST1N



Pump Type	Displacement cm ³ /rev	Max. Pressure (bar)	Max. Speed rpm	A	B	Inlet	Outlet
						C	c
GPR30.017.CRM1N	17,2	300	3000	119,0	173,6	G 1/2"	G 1/2"
GPR30.017.ARM1N							
GPR30.027.CRM1N	27,1	290	2750	122,2	180,0	G 3/4"	G 3/4"
GPR30.027.ARM1N							
GPR30.034.CRM1N	34,4	280	2500	124,5	184,6	G 1"	G 1"
GPR30.034.ARM1N							
GPR30.043.CRM1N	42,9	270	2000	127,4	190,4	G 1-1/4"	G 1-1/4"
GPR30.043.ARM1N							
GPR30.051.CRM1N	51,2	240	1750	129,5	194,5	G 1-1/4"	G 1-1/4"
GPR30.051.ARM1N							
GPR30.061.CRM1N	60,7	220	1750	133,2	202,0	G 1"	G 1"
GPR30.061.ARM1N							
GPR30.073.CRM1N	73,0	200	1750	137,1	209,7	G 1"	G 1"
GPR30.073.ARM1N							
GPR30.082.CRM1N	81,4	190	1750	140,1	215,5	G 1-1/4"	G 1-1/4"
GPR30.082.ARM1N							
GPR30.100.CRM1N	99,7	180	1750	145,8	227,1	G 1-1/4"	G 1-1/4"
GPR30.100.ARM1N							

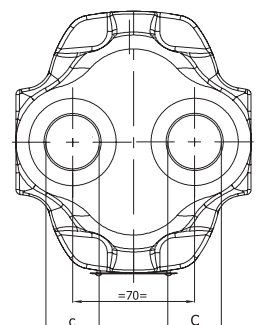
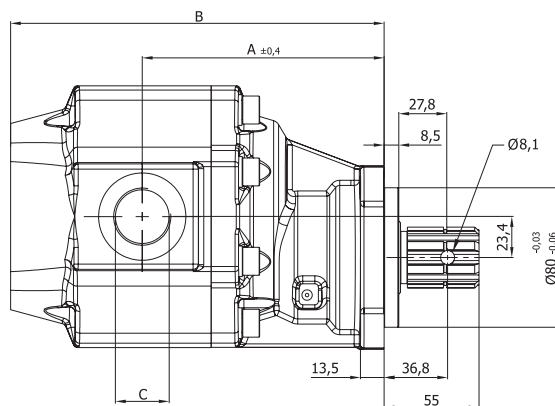
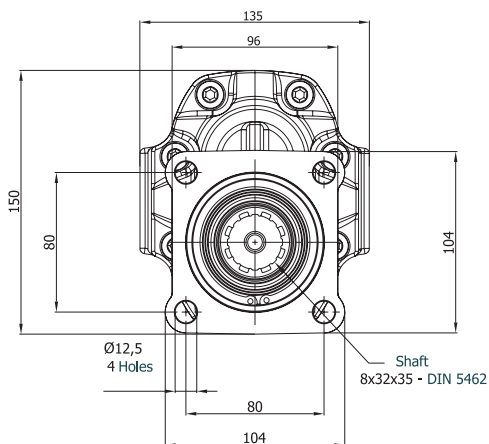

ORDERING CODE OF GP30 PUMPS

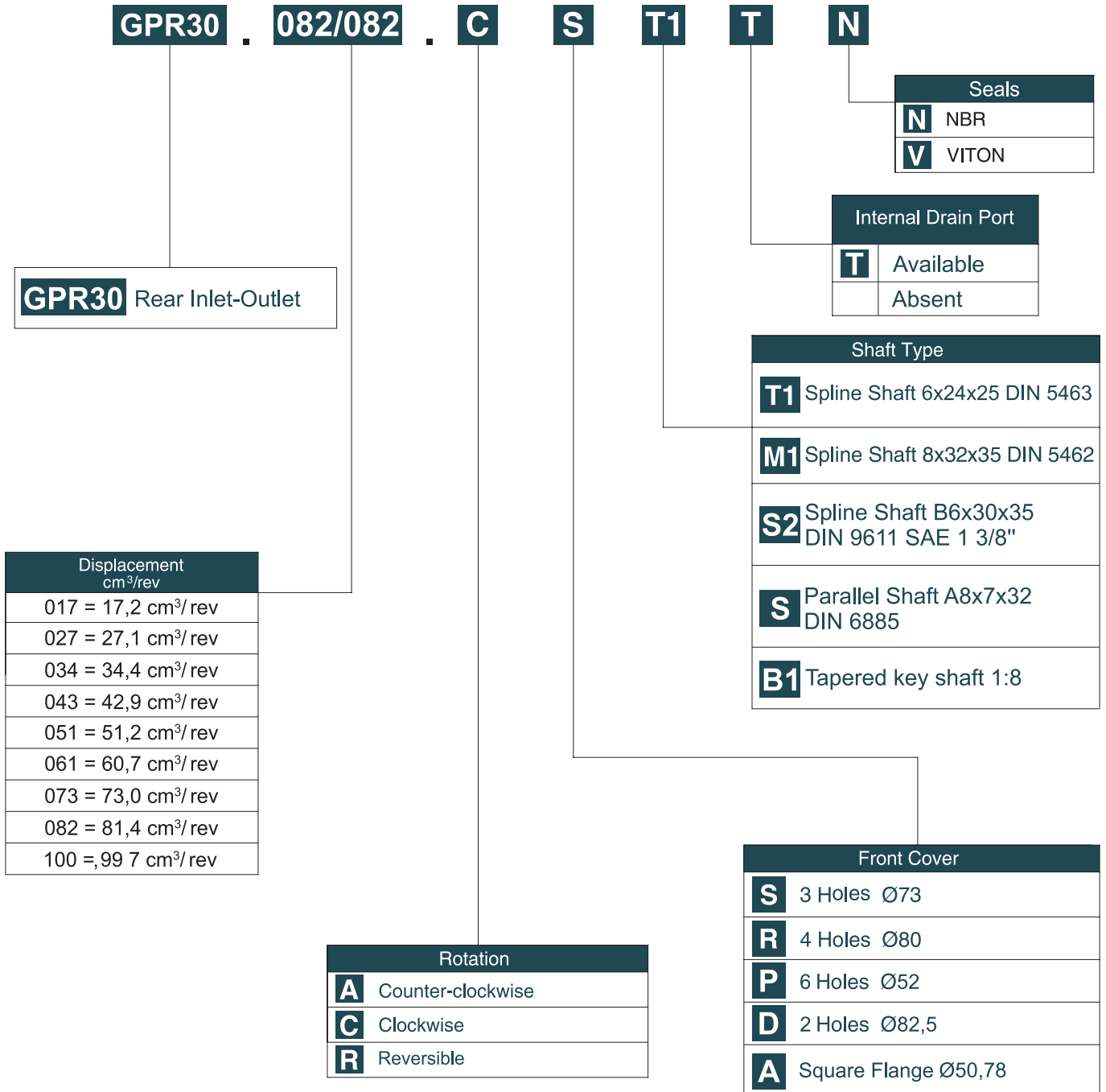

Code Example (Single) ; GPR30.082.CST1N

Code Example (Tandem) ; GPR30.082/082.CST1N



Pump Type	Displacement cm ³ /rev	Max. Pressure (bar)	Max. Speed rpm	A ±0,4	B	Inlet	Outlet
						C	c
GP40.063.CRM1N	63,8	280	2750	136,3	203,0	G 1"	G 3/4"
GP40.063.ARM1N							
GP40.073.CRM1N	72,2	260		137,3	204,6		
GP40.073.ARM1N							
GP40.087.CRM1N	86,1	240	2500	141,0	209,6	G 1-1/4"	G 1"
GP40.087.ARM1N							
GP40.109.CRM1N	107,3	220		145,0	217,3		
GP40.109.ARM1N							
GP40.133.CRM1N	131,6	180	148,0	225,9	G 1-1/2"		
GP40.133.ARM1N							
GP40.151.CRM1N	148,3	153,3	232,3				
GP40.151.ARM1N							

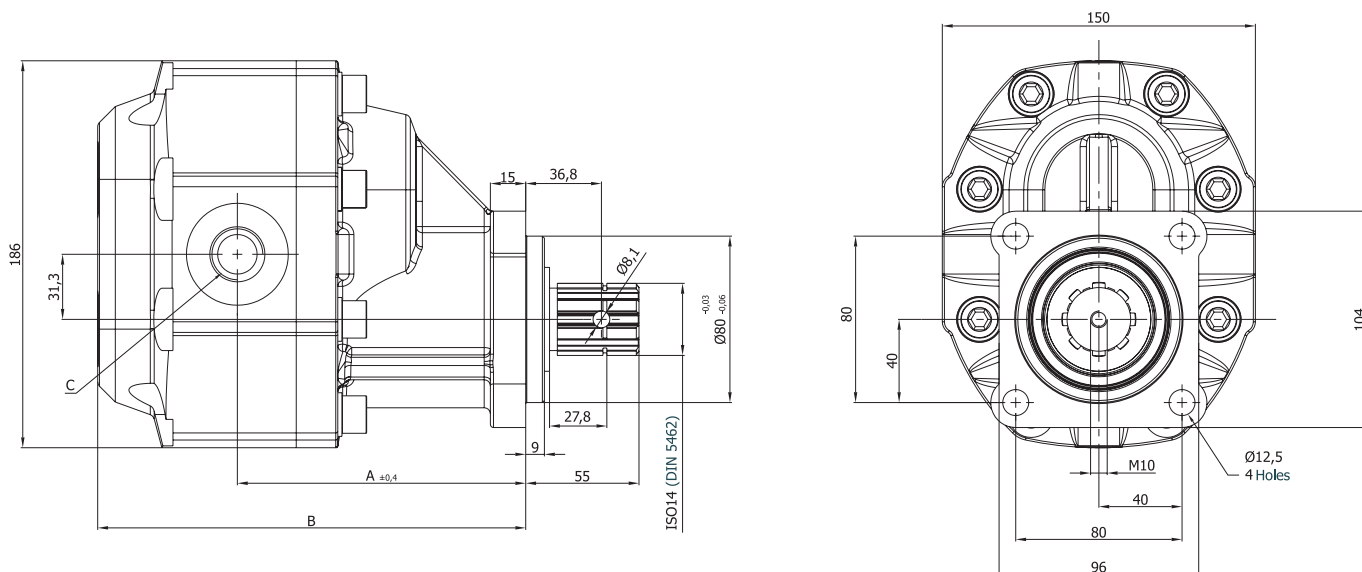

ORDERING CODE OF GP40 PUMPS

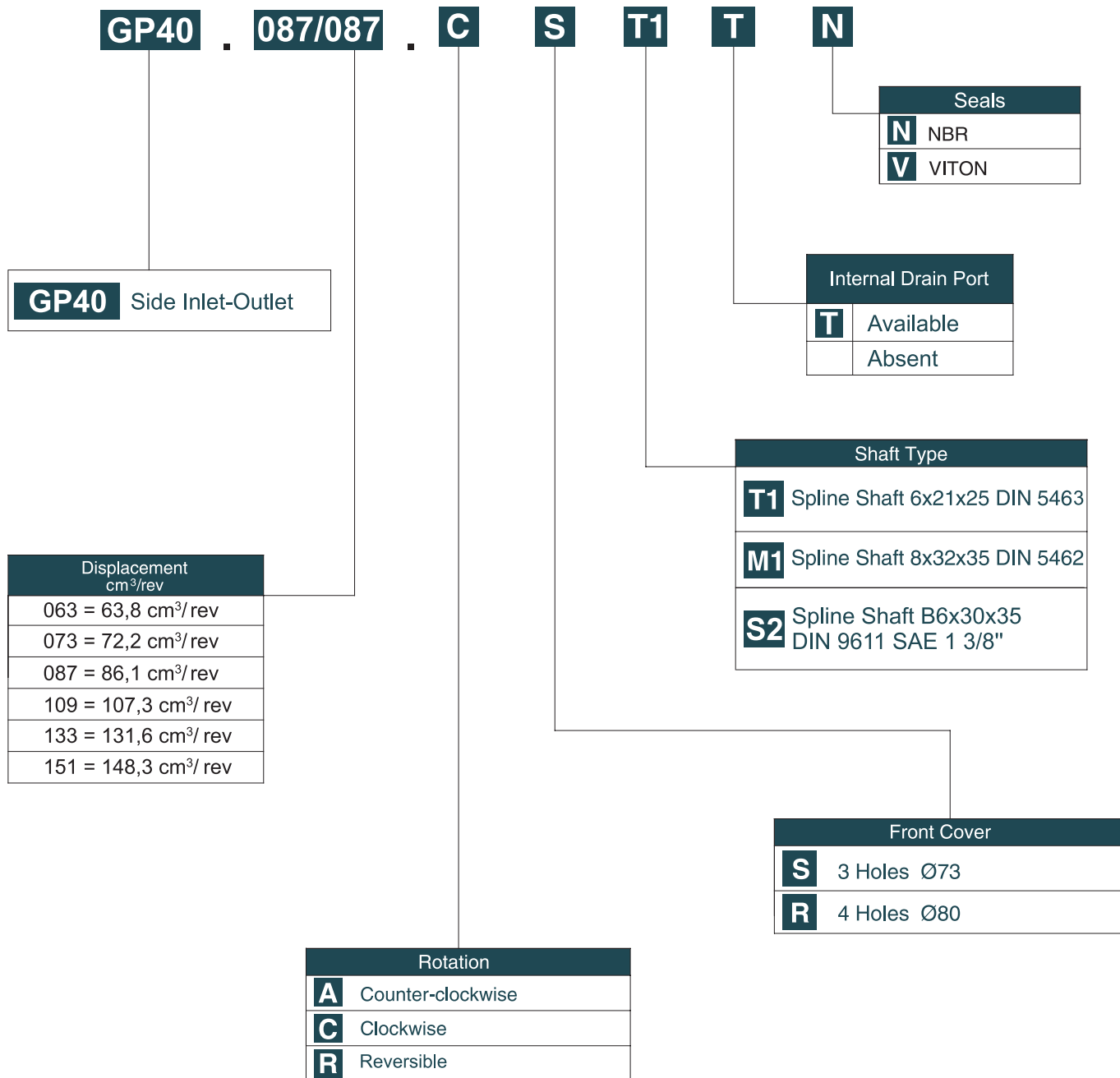

Code Example (Single) ; GP40.087.CST1N

Code Example (Tandem) ; GP40.087/087.CST1N

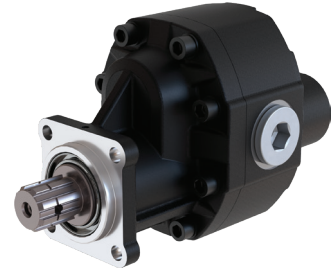

Pump Type	Displacement cm ³ /rev	Max. Pressure (bar)	Max. Speed rpm	A ±0.4	B	Inlet	Outlet
						C	c
GPR40.063.CRM1N	63,8	280	2750	136,3	208,5	G 1"	G 3/4"
GPR40.063.ARM1N							
GPR40.073.CRM1N	72,2	260		137,3	210,0		
GPR40.073.ARM1N							
GPR40.087.CRM1N	86,1	240	2500	141,0	214,0	G 1-1/4"	G 1"
GPR40.087.ARM1N							
GPR40.109.CRM1N	107,3	220		145,0	221,5		
GPR40.109.ARM1N							
GPR40.133.CRM1N	131,6	180	148,0	230,5	G 1-1/2"		
GPR40.133.ARM1N							
GPR40.151.CRM1N	148,3	153,3	236,5				
GPR40.151.ARM1N							

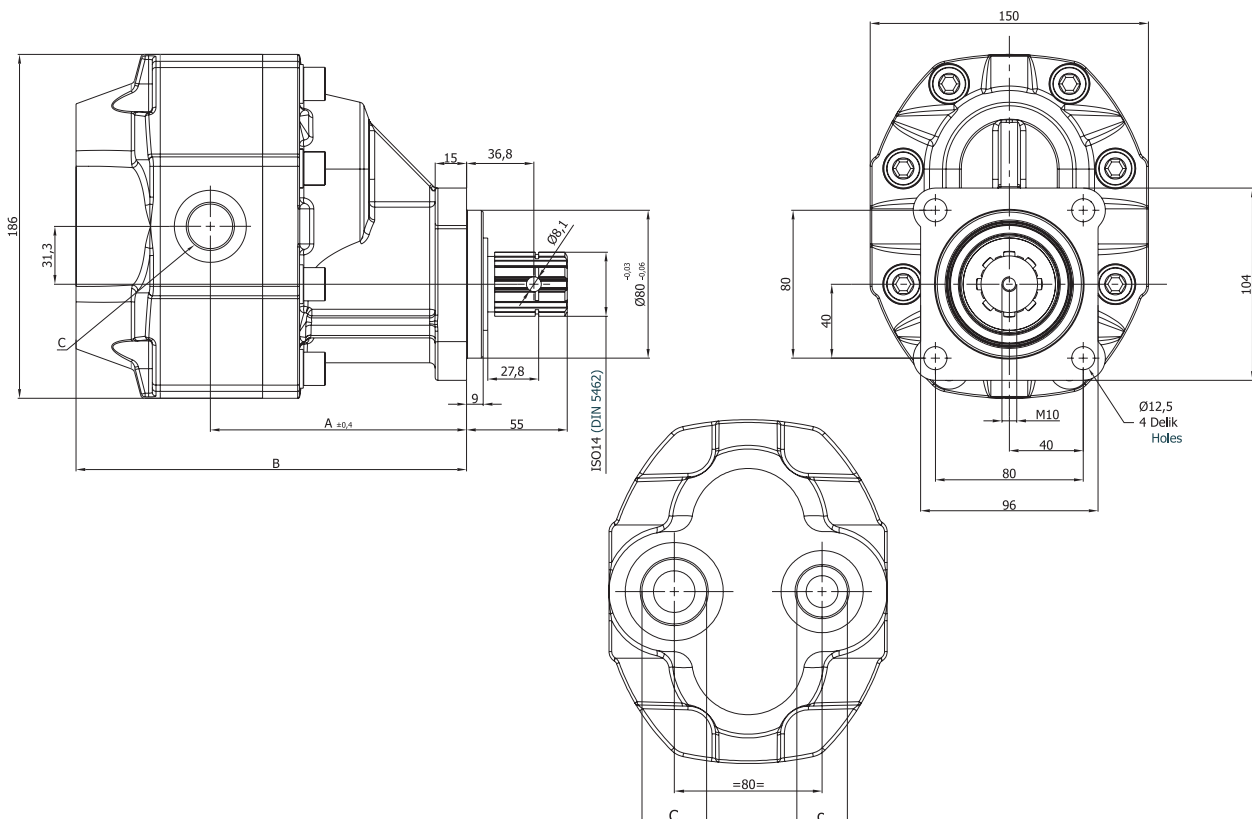

ORDERING CODE OF GP40 PUMPS

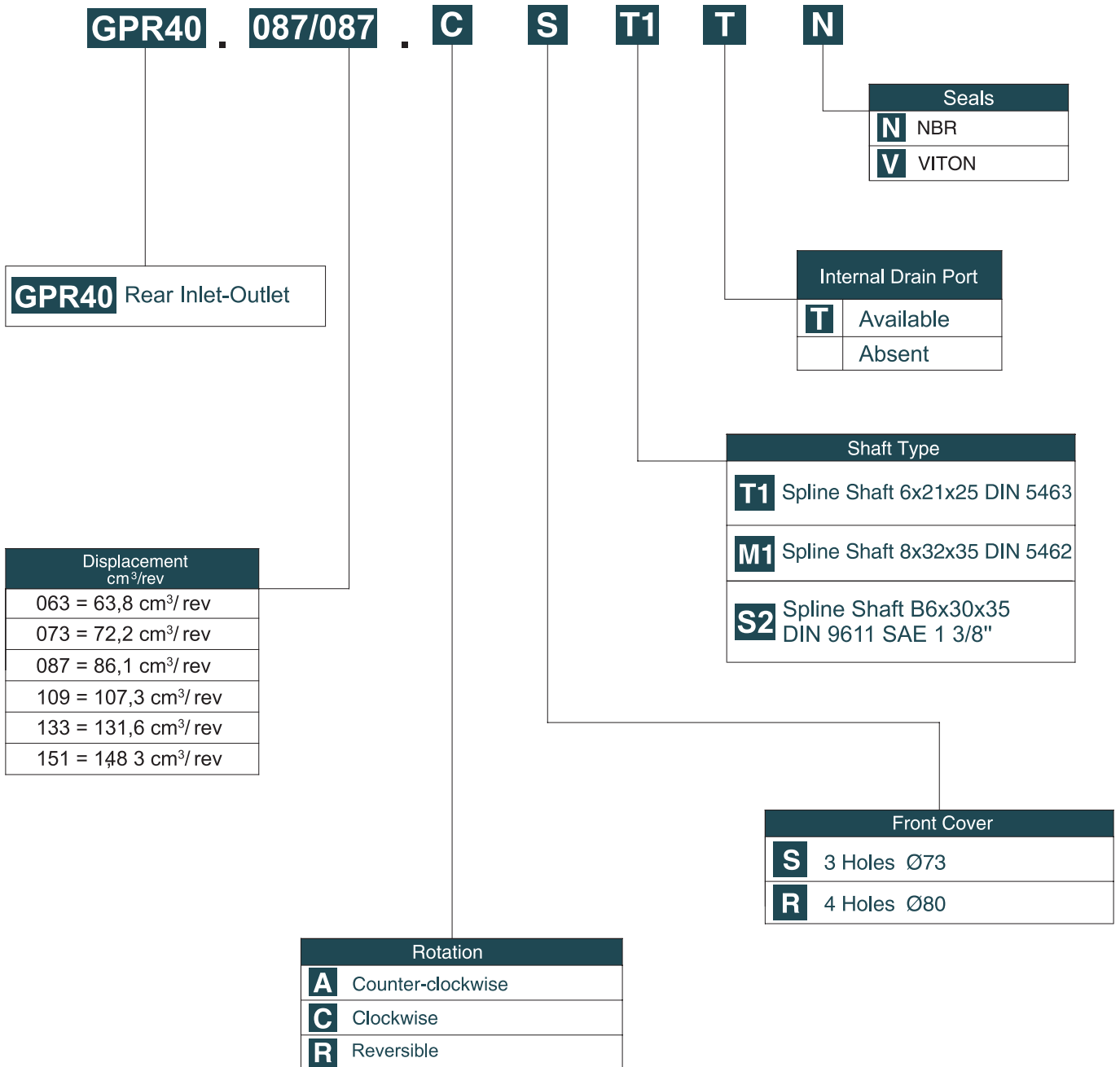

Code Example (Single) ; GPR40.087.CST1N

Code Example (Tandem) ; GPR40.087/087.CST1N



Motor Type	Displacement cm ³ /rev	Max. Pressure (bar)	Max. Speed rpm	A ±0,4	B	Inlet/Outlet			Drain
						C	D	E	S
APM20.040.RAB02EGN	3,9	250	3500	42,2	89,3	13,5	30,2	M6	G1/4
APM20.060.RAB02EGN	5,9			43,8	92,4				
APM20.080.RAB02EGN	8,0			45,4	95,6				
APM20.095.RAB02EGN	9,4			46,5	97,9				
APM20.115.RAB02EGN	11,4		3000	48,2	101,0				
APM20.140.RAB02EGN	13,9			50,0	105,0				
APM20.160.RAB02EGN	16,0			51,7	108,1				
APM20.190.RAB02EGN	19,2			60,2	125,1				
APM20.220.RAB02EGN	21,9	210	2500	62,3	129,5	20	40	M8	
APM20.250.RAB02EGN	24,8	190		64,8	134,6				
APM20.280.RAB02EGN	27,9	170	2200	67,0	138,9				
APM20.320.RAB02EGN	32,0	160		2000	70,0				
APM20.340.RAB02EGN	34,0	150	71,5		148,0				
APM20.380.RAB02EGN	38,0	140	1750	74,8	154,5				
APM20.400.RAB02EGN	40,0	140		76,5	158,0				

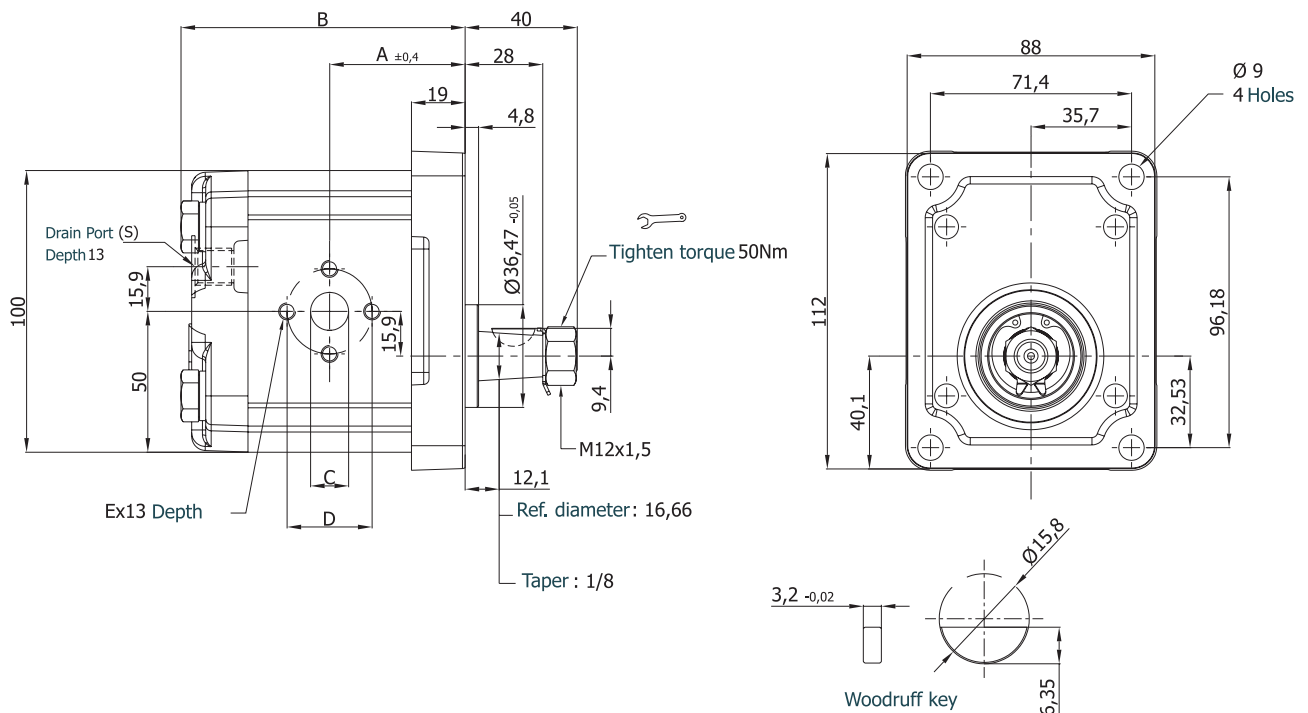

ORDERING CODE OF GROUP 20 MOTORS

APM20 . 115 . R A B 02 E G O N

Motor Type
APM20 Aluminium Body Gear Motor

Displacement cm ³ /rev
040 = 3,9 cm ³ /rev
060 = 5,9 cm ³ /rev
080 = 8,0 cm ³ /rev
095 = 9,4 cm ³ /rev
115 = 11,4 cm ³ /rev
140 = 13,9 cm ³ /rev
160 = 16,0 cm ³ /rev
190 = 19,2 cm ³ /rev
220 = 21,9 cm ³ /rev
250 = 24,8 cm ³ /rev
280 = 27,9 cm ³ /rev
320 = 32,0 cm ³ /rev
340 = 34,0 cm ³ /rev
380 = 38,0 cm ³ /rev
400 = 40,0 cm ³ /rev











Rotation
A = Counter-clockwise
C = Clockwise
R = Reversible













Outboard Bearing
O Available
Absent







Seal
N NBR
V Viton

Drain Line
G G1/4"
U 7/16-20 UNF
M M12x1,5

Rear Cover
S Standard
E External Drain Rear Port
R1 Relief Valve (10 - 90 Bar)
R2 Relief Valve (70 - 140 Bar)
R3 Relief Valve (120 - 190 Bar)
D Flow Divider Valve
H Flow Control Valve With Relief Valve
L Load Sensing Valve
T Check Valve
P Rear Inlet-Outlet
C Flow Control Valve Pressure Compensated

Front Cover		
A Square flange	Ø36,47 mm	
B 2 Bolts - Centering	Ø50 mm	
C 2 Bolts - Centering with oring	Ø52 mm	
D 2 Bolts SAE 'A'	Ø82,55 mm	
E 2 Bolts - Centering	Ø50 mm	
G Square flange	Ø80 mm	
H Outboard bearing	Ø80 mm	
K 2 Bolts SAE 'B'	Ø101,6 mm	
M 2 Bolts - Centering	Ø52,34 mm	
N 4 Bolts - Centering O-ring	Ø52 mm	

Drive Shaft		
A Tapered key shaft	1:5	 B E G
B Tapered key shaft	1:8	 A
C SAE spline shaft 9T		 B D
E Tang drive shaft		 C H
F SAE spline shaft 11T		 D
G Spline shaft (B17x14)		 A B E G
H Parallel shaft		 B D G
K Tapered key shaft	1:5	 H
L Tapered key shaft	1:5	 G
M SAE spline shaft 16/32 DP 10T		 D
N Tapered key shaft	1:8	 M
T Tang drive shaft		 N

Inlet and Outlet Ports		
01		Rectangular
02		Diamond
03		ISO 6149 oring boss
04		UNF thread
05		Pipe thread
06		SAE Square Flange Thread Metric

Code Example ; APM20.115.RAB02EGN

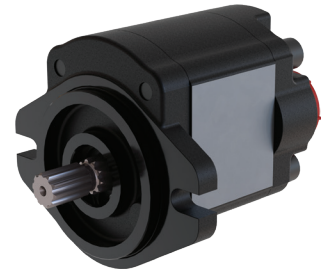

Motor Type	Displacement cm ³ /rev	Max. Pressure (bar)	Max. Speed rpm	A ±0,4	B	Inlet/Outlet			Drain
						C	D	E	S
DKM20.040.RHK01EMON	3,9	280	3500	89,7	136,7	15	35	M6	M12x1,5
DKM20.060.RHK01EMON	5,9			91,2	139,8				
DKM20.080.RHK01EMON	8,0			92,8	142,9				
DKM20.095.RHK01EMON	9,4			94,0	145,2				
DKM20.115.RHK01EMON	11,4			95,5	148,4				
DKM20.140.RHK01EMON	13,9	260	3000	97,5	152,3	20	40	M6	M12x1,5
DKM20.160.RHK01EMON	16,0			99,0	155,4				
DKM20.190.RHK01EMON	19,2			107,5	172,4				
DKM20.220.RHK01EMON	21,9	190	2500	109,7	176,8	20	40	M6	M12x1,5
DKM20.250.RHK01EMON	24,8	160	2200	112,3	181,9				
DKM20.280.RHK01EMON	27,9			114,5	186,2				

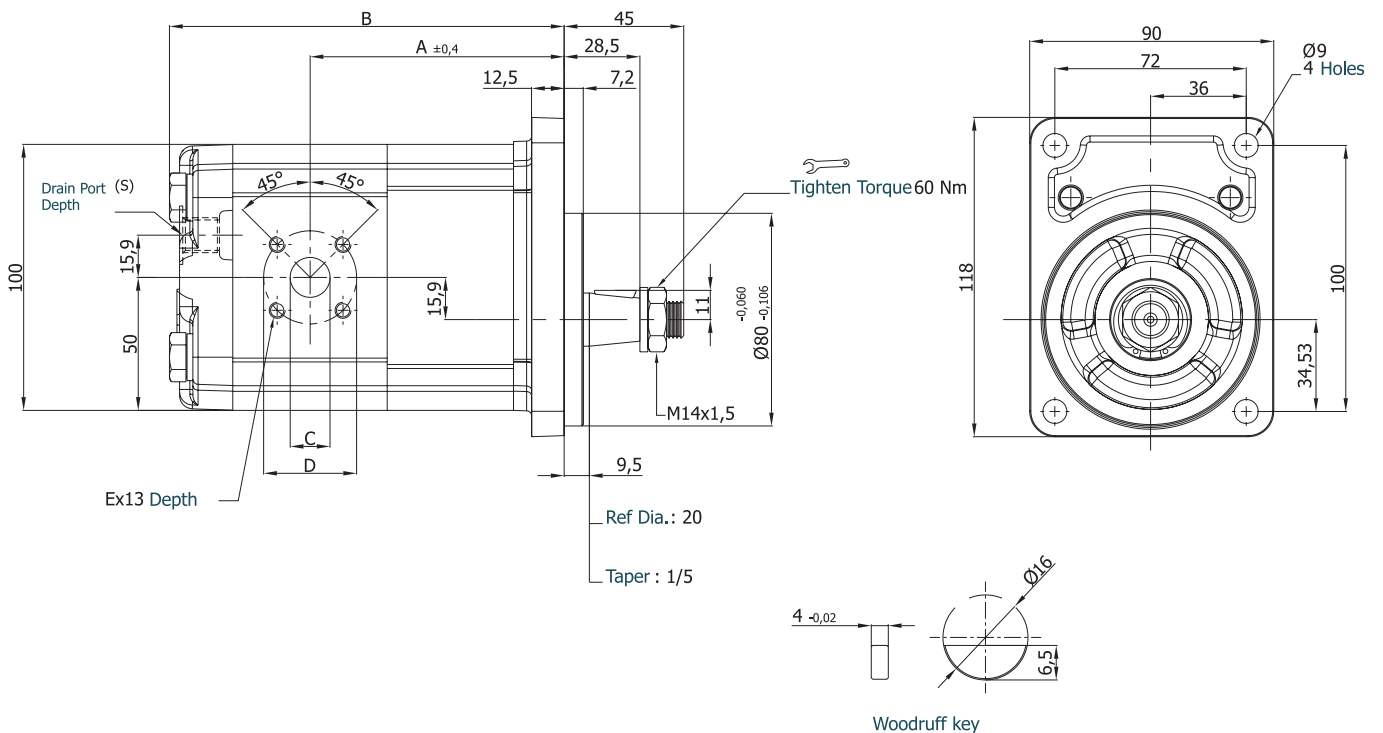

ORDERING CODE OF GROUP 20 MOTORS

DKM20 . 115 . R A B 02 E G O N

Motor Type
DKM20 Cast Iron Body Gear Motor

Displacement cm ³ /rev
040 = 3,9 cm ³ /rev
060 = 5,9 cm ³ /rev
080 = 8,0 cm ³ /rev
095 = 9,4 cm ³ /rev
115 = 11,4 cm ³ /rev
140 = 13,9 cm ³ /rev
160 = 16,0 cm ³ /rev
190 = 19,2 cm ³ /rev
220 = 21,9 cm ³ /rev
250 = 24,8 cm ³ /rev
280 = 27,9 cm ³ /rev
320 = 32,0 cm ³ /rev
340 = 34,0 cm ³ /rev
380 = 38,0 cm ³ /rev
400 = 40,0 cm ³ /rev

Rotation
A = Counter-clockwise
C = Clockwise
R = Reversible

Outboard Bearing
O Available
Absent

Seal
N NBR
V Viton

Drain Line
G G1/4"
U 7/16-20 UNF
M M12x1,5

Rear Cover
S Standard
E External Drain Rear Port
R1 Relief Valve (10 - 90 Bar)
R2 Relief Valve (70 - 140 Bar)
R3 Relief Valve (120 - 190 Bar)
D Flow Divider Valve
H Flow Control Valve With Relief Valve
L Load Sensing Valve
T Check Valve
P Rear Inlet-Outlet
C Flow Control Valve Pressure Compensated

Front Cover		
A Square flange	Ø36,47 mm	
B 2 Bolts - Centering	Ø50 mm	
C 2 Bolts - Centering with oring	Ø52 mm	
D 2 Bolts SAE 'A'	Ø82,55 mm	
E 2 Bolts - Centering	Ø50 mm	
G Square flange	Ø80 mm	
H Outboard bearing	Ø80 mm	
K 2 Bolts SAE 'B'	Ø101,6 mm	
M 2 Bolts - Centering	Ø52,34 mm	
N 4 Bolts - Centering O-ring	Ø52 mm	

Drive Shaft		
A Tapered key shaft	1:5	
B Tapered key shaft	1:8	
C SAE spline shaft 9T		
E Tang drive shaft		
F SAE spline shaft 11T		
G Spline shaft (B17x14)		
H Parallel shaft		
K Tapered key shaft	1:5	
L Tapered key shaft	1:5	
M SAE spline shaft 16/32 DP 10T		
N Tapered key shaft	1:8	
T Tang drive shaft		

Inlet and Outlet Ports		
01		Rectangular
02		Diamond
03		ISO 6149 oring boss
04		UNF thread
05		Pipe thread
06		SAE Square Flange Thread Metric

Code Example ; DKM20.115.RAB02EGN

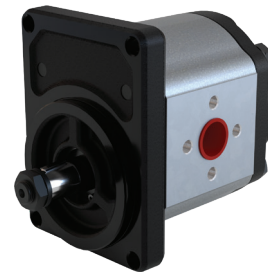

Motor Type	Displacement cm ³ /rev	Max. Pressure (bar)	Max. Speed rpm	A ±0,4	B	Inlet		Drain
						C	E	S
APM30.190.RHP05EGN	19,0	230	3000	63,0	130,8	24,5	G3/4"	G 3/8"
APM30.220.RHP05EGN	22,0			64,0	133,8			
APM30.250.RHP05EGN	25,0			66,0	136,8			
APM30.280.RHP05EGN	28,0			67,0	139,8			
APM30.320.RHP05EGN	32,0	210	2750	69,0	142,8	30,5	G1"	
APM30.350.RHP05EGN	35,0			70,0	145,8			
APM30.380.RHP05EGN	38,0			72,0	148,8			
APM30.420.RHP05EGN	42,0			74,0	152,8			
APM30.450.RHP05EGN	45,0	200	2500	75,0	155,8	39,0	G1 1/4"	
APM30.510.RHP05EGN	51,0			78,0	160,8			
APM30.560.RHP05EGN	56,0	180	2000	80,0	165,8			

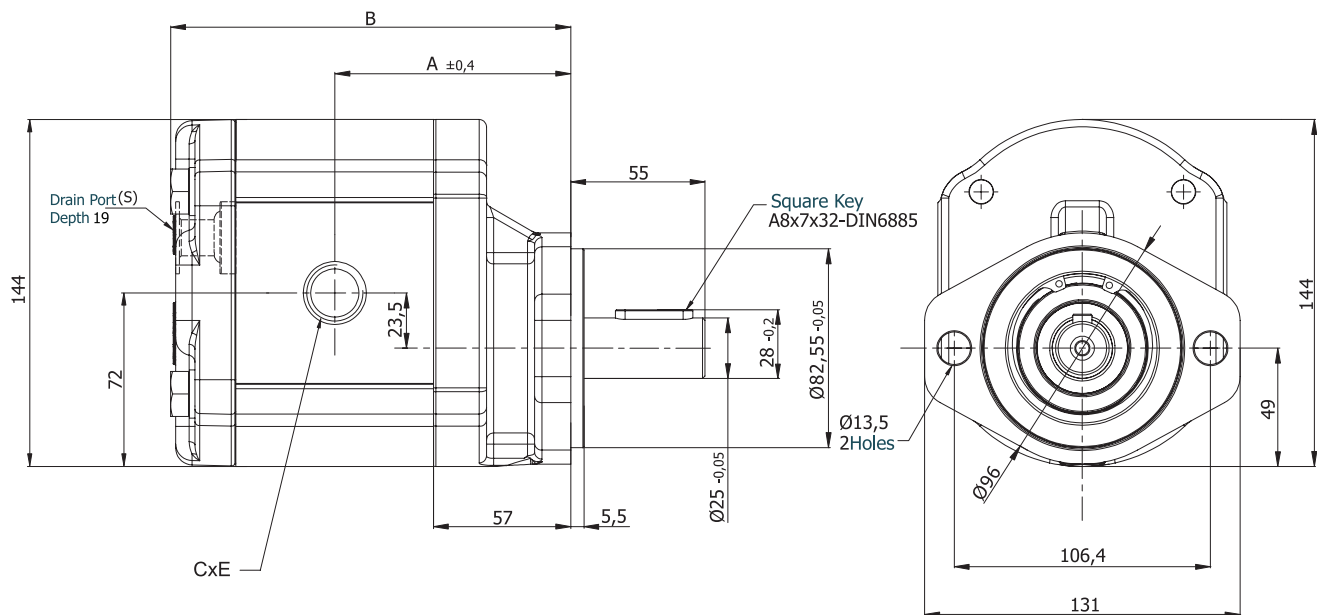

ORDERING CODE OF GROUP30 MOTORS

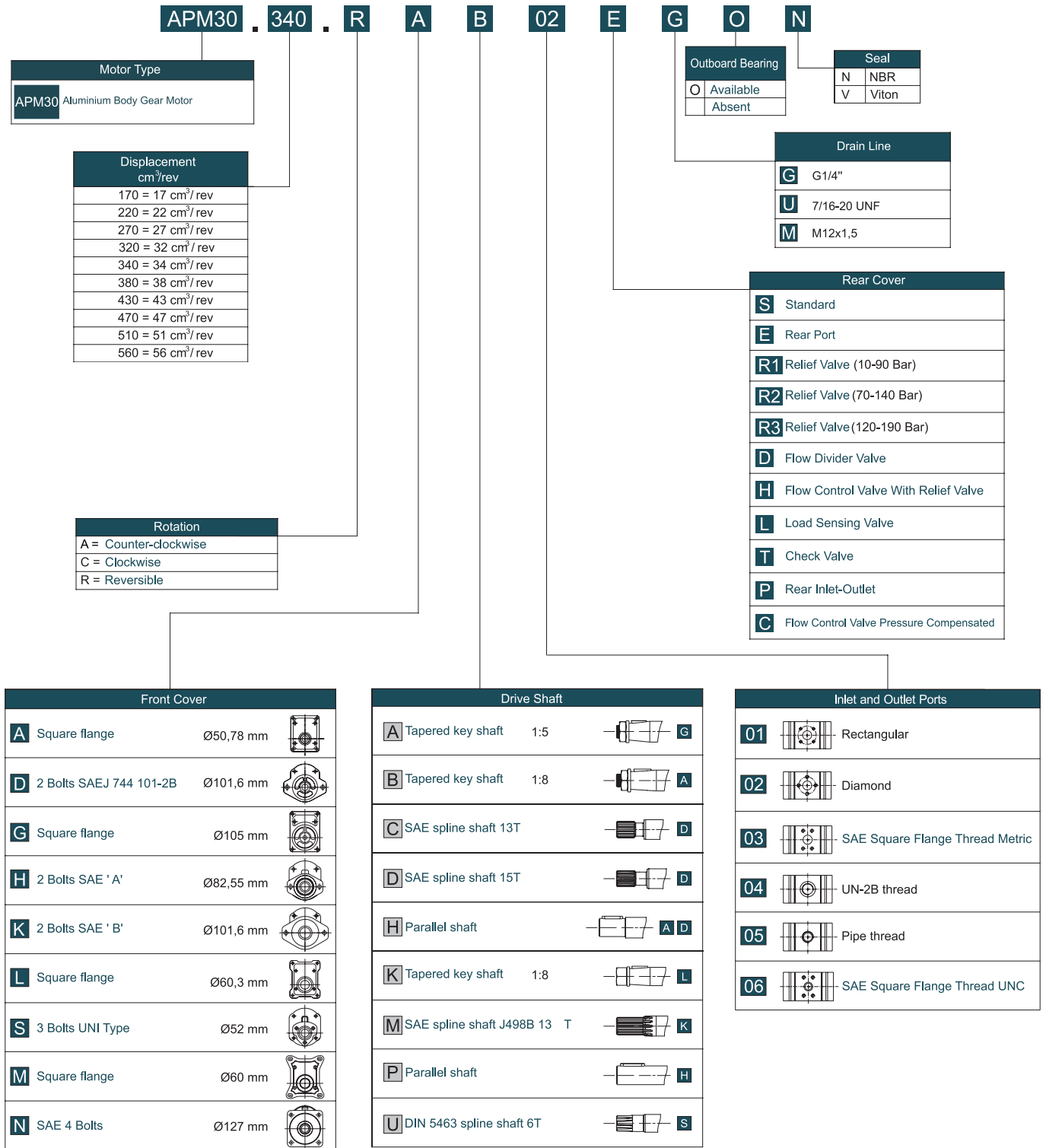

Code Example ; APM30.340.RAB02EGN



Motor Type	Displacement cm ³ /rev	Max. Pressure (bar)	Max. Speed rpm	A	B	Inlet	Outlet
						C	c
GPM30.017.RRM1N	17,2	300	3000	119,0	172,6	G 1/2"	G 1/2"
GPM30.027.RRM1N	27,1	290		122,2	179,0		
GPM30.034.RRM1N	34,4	280	2750	124,5	183,6	G 3/4"	G 3/4"
GPM30.043.RRM1N	42,9	270	2500	127,4	189,4		
GPM30.051.RRM1N	51,2	240		2000	129,5	193,5	G 1"
GPM30.061.RRM1N	60,7	220	1750	133,2	201,0		
GPM30.073.RRM1N	73,0	200		137,1	208,7	G 1-1/4"	G 1-1/4"
GPM30.082.RRM1N	81,4	190	140,0	214,5			
GPM30.100.RRM1N	99,7	180	1750	145,8	226,1		

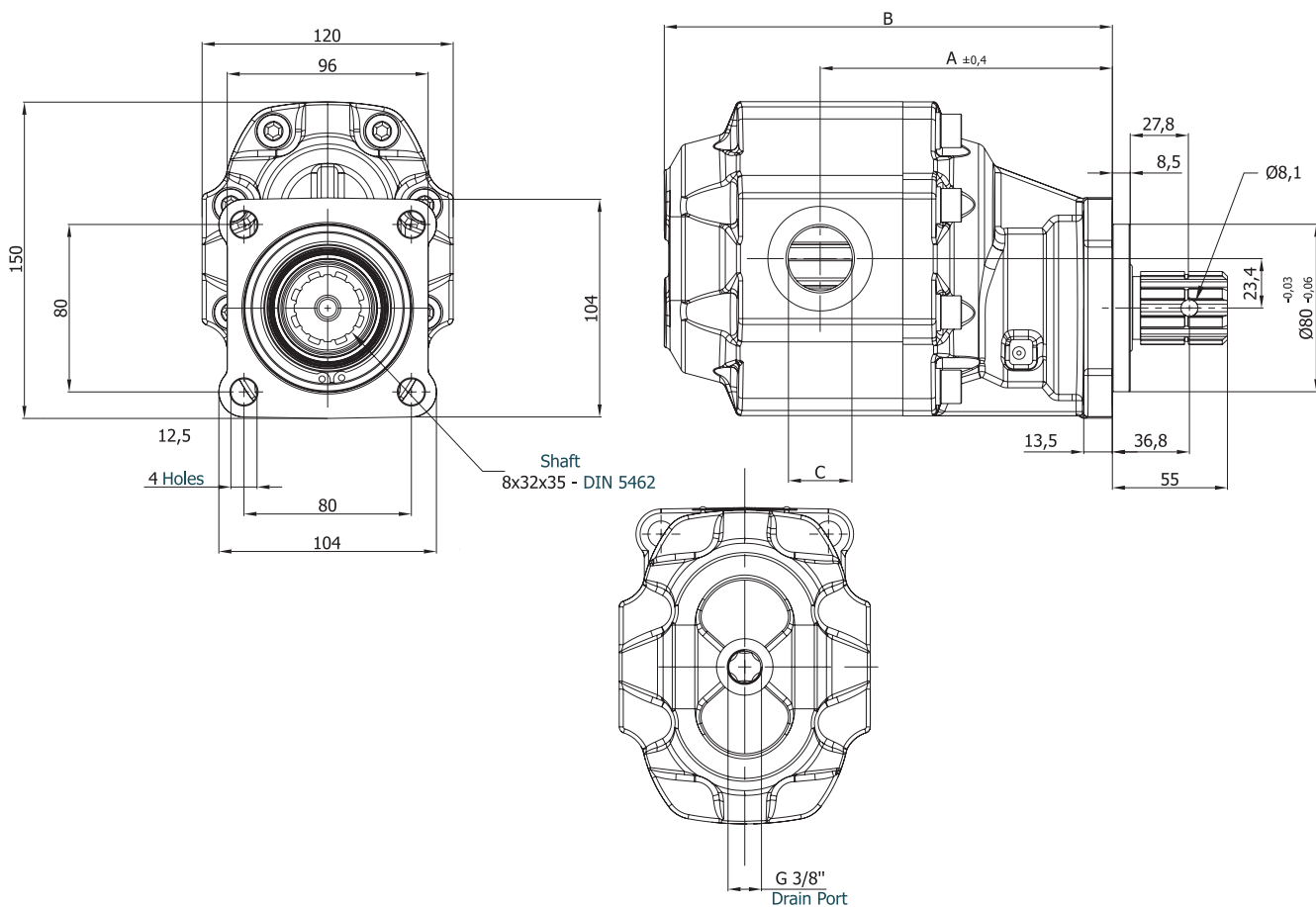

ORDERING CODE OF GPM30 MOTORS

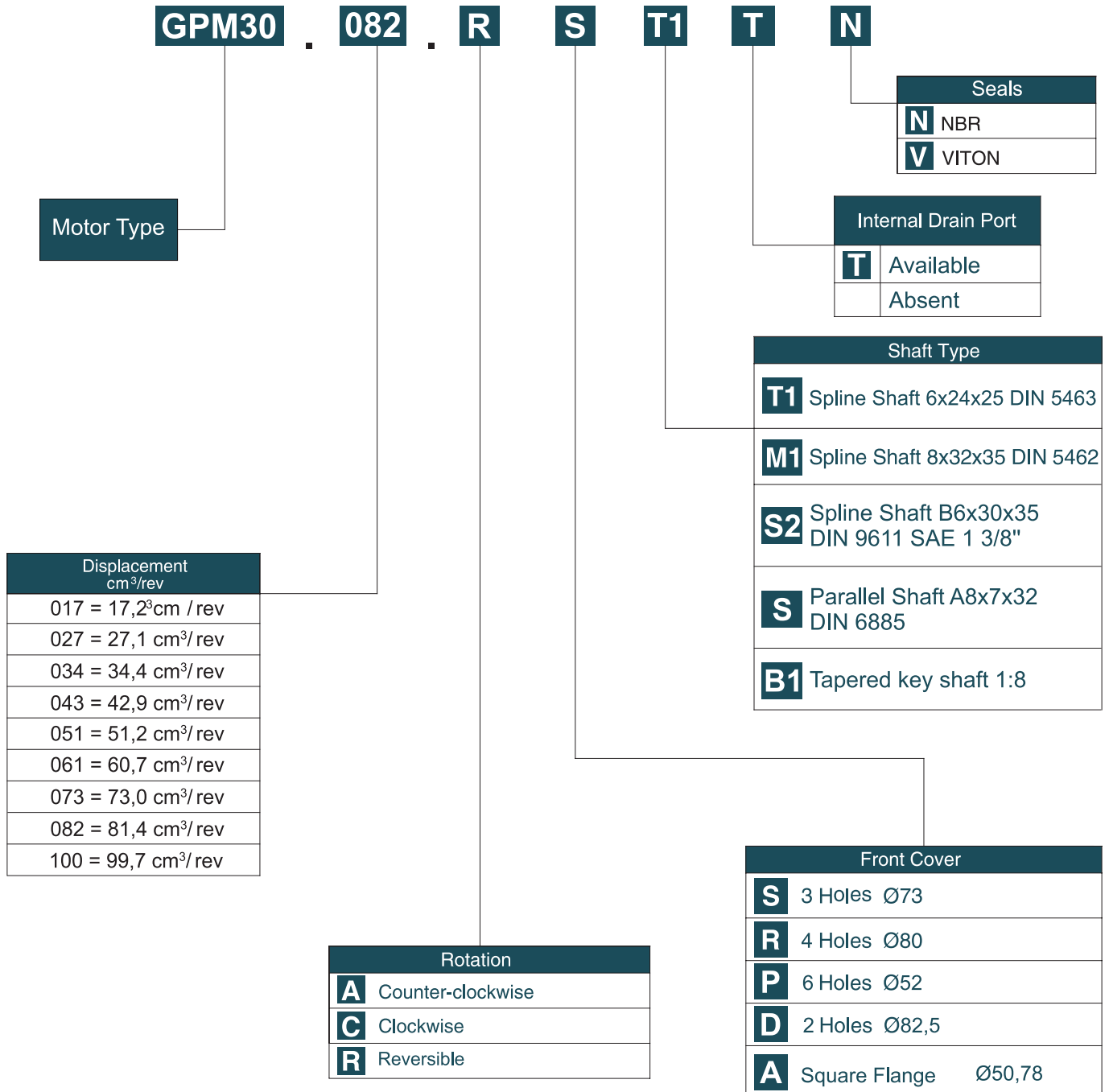

Code Example ; GPM30.082.RST1N



Motor Type	Displacement cm ³ /rev	Max. Pressure (bar)	Max. Speed rpm	A	B	Inlet	Outlet
						C	c
GPM40.063.RRS2N	63,8	280	2750	136,3	203,0	G 1"	G 1"
GPM40.073.RRS2N	72,2			137,3	204,6		
GPM40.087.RRS2N	86,1	260		141,0	209,6	G 1-1/4"	G 1-1/4"
GPM40.109.RRS2N	107,3	240		145,0	217,3		
GPM40.133.RRS2N	131,6	220	148,0	225,9			
GPM40.151.RRS2N	148,3	180	2500	153,3	232,3		

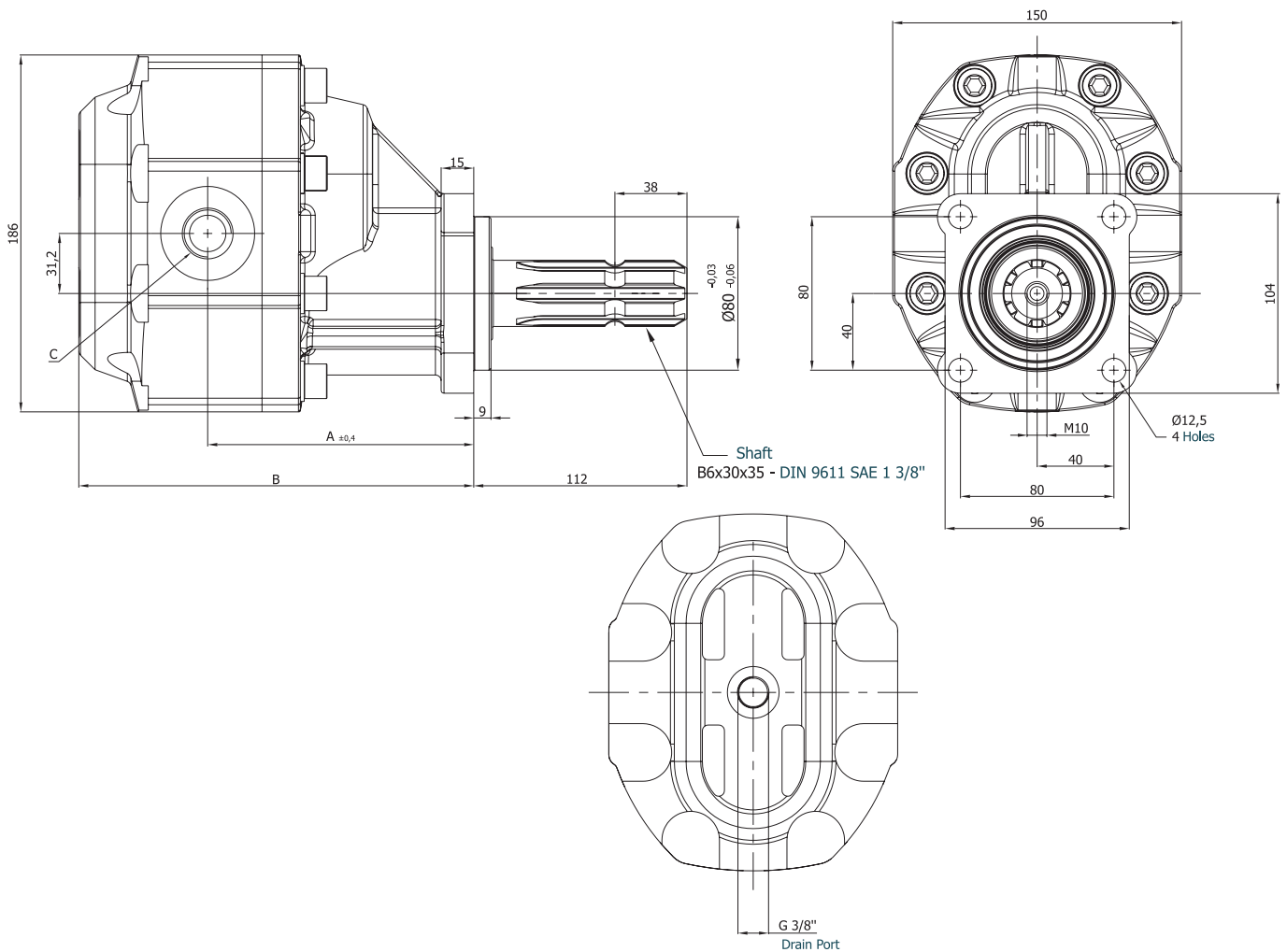

ORDERING CODE OF GPM40 MOTORS

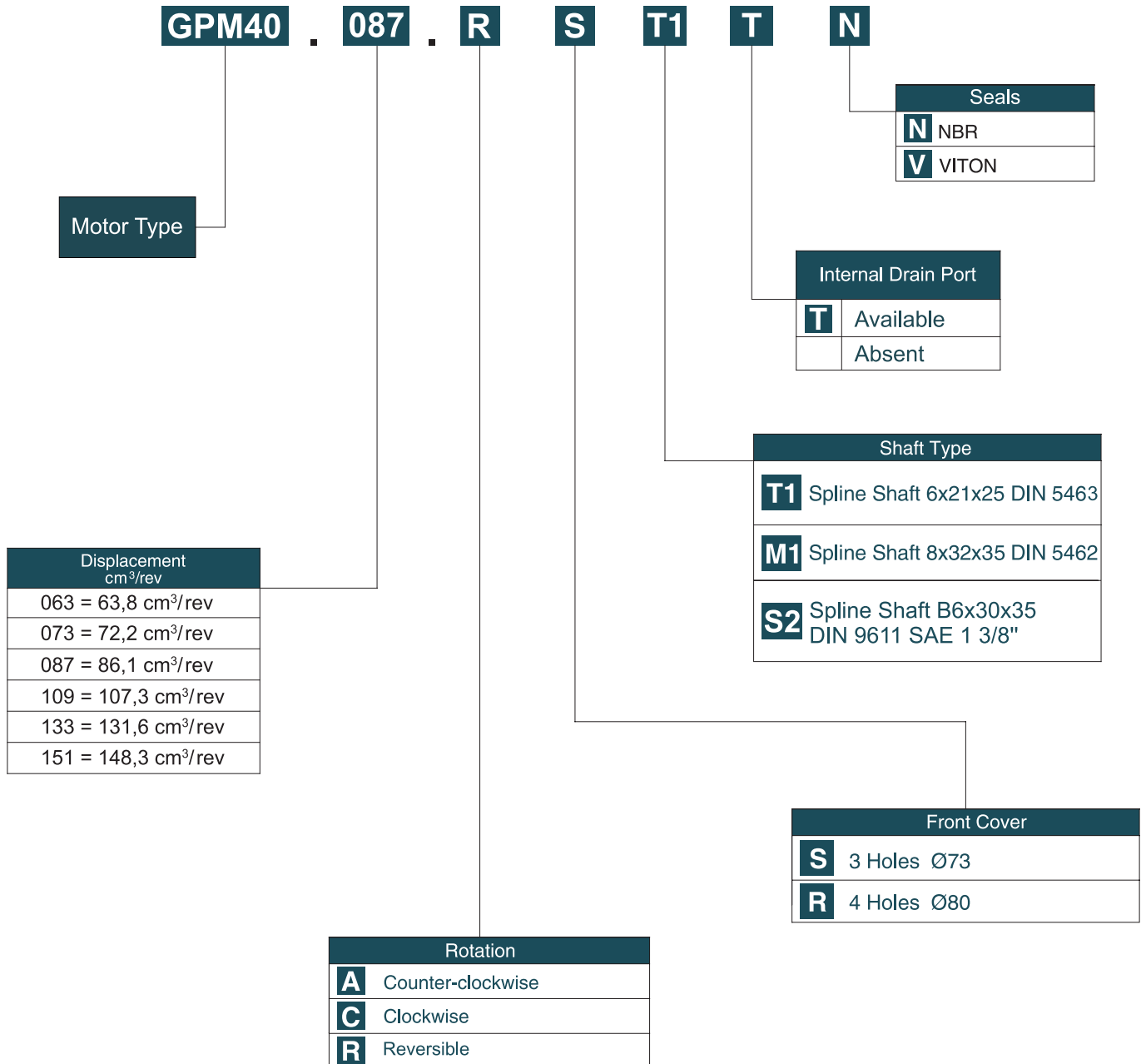

Code Example; GPM40.087.RST1N

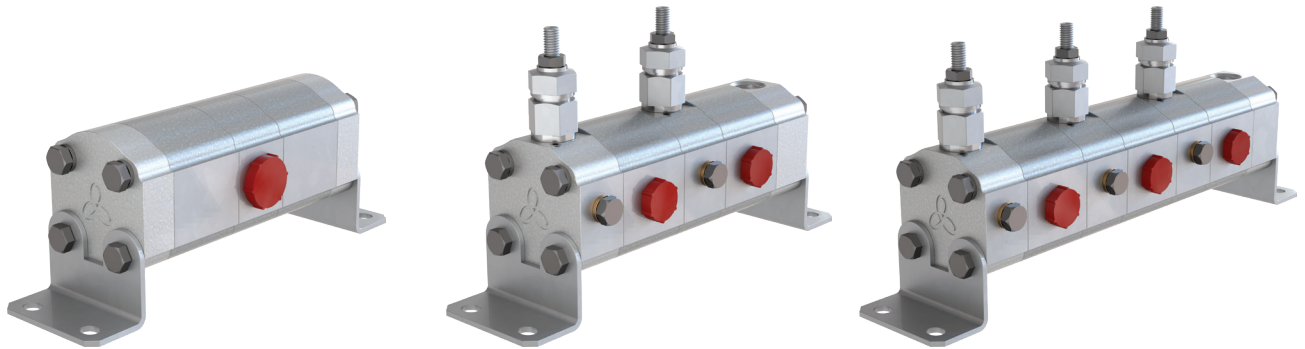

Type	cm ³ /rev	A	Inlet	Outlet	(L) Length						
					2	3	4	5	6	7	8
AFD10.X.1.2N	1,2	39	G 1/2"	G 3/8"	203,0	277,0	351,0	425,0	499,0	573,0	647,5
AFD10.X.1.7N	1,7	41			207,0	283,0	359,0	435,0	511,0	587,0	663,5
AFD10.X.2.3N	2,3	43			211,0	289,0	367,0	443,0	523,0	601,0	679,5
AFD10.X.2.7N	2,7	45			215,0	295,0	375,0	455,0	535,0	615,0	695,5
AFD10.X.3.2N	3,2	46,5			218,0	300,0	381,5	463,0	545,0	626,5	708,0
AFD10.X.3.8N	3,8	49			223,0	307,0	391,0	475,0	559,0	643,0	727,5
AFD10.X.4.3N	4,3	51			227,0	313,0	399,0	485,0	571,0	657,0	743,5
AFD10.X.5.0N	5,0	54			233,0	322,0	411,0	500,0	589,0	678,0	767,5
AFD10.X.6.3N	6,3	59			243,0	337,0	431,0	525,0	619,0	713,0	807,5
AFD10.X.7.8N	7,8	65			255,0	355,0	455,0	555,0	655,0	755,0	855,5
AFD10.X.9.5N	9,5	72			269,0	376,0	483,0	590,0	697,0	804,0	911,5

Number of Elements	2	3	4	5	6	7	8
Number of Inlets	1	1	2	2	3	3	4

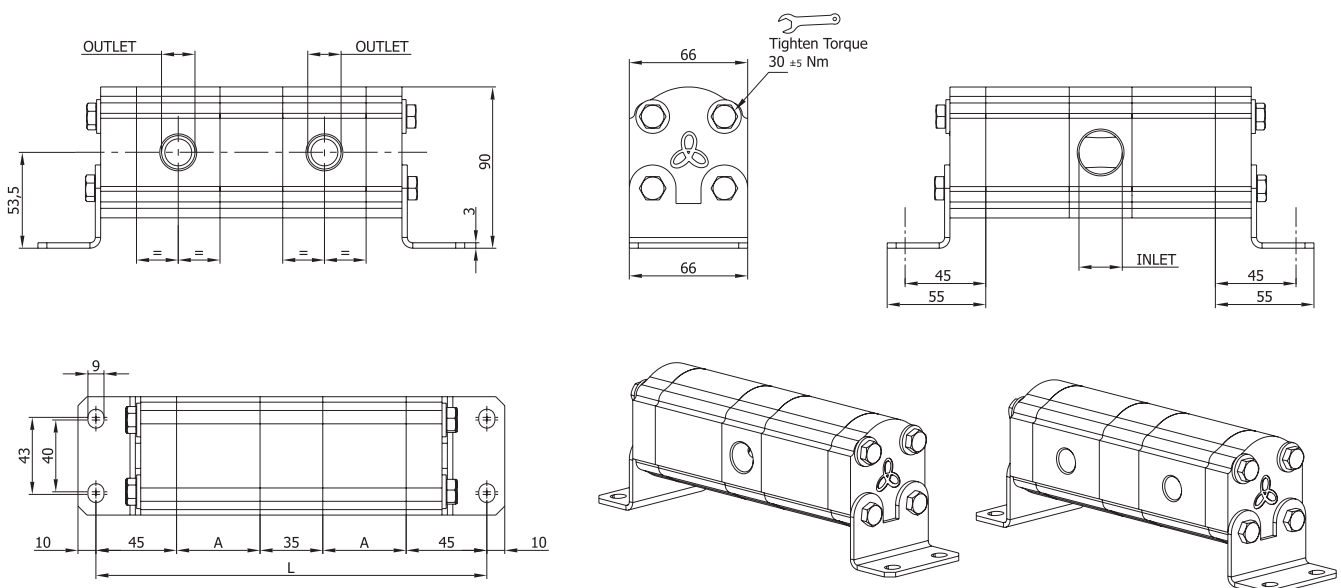

ORDERING CODE OF GROUP 10 FLOW DIVIDERS

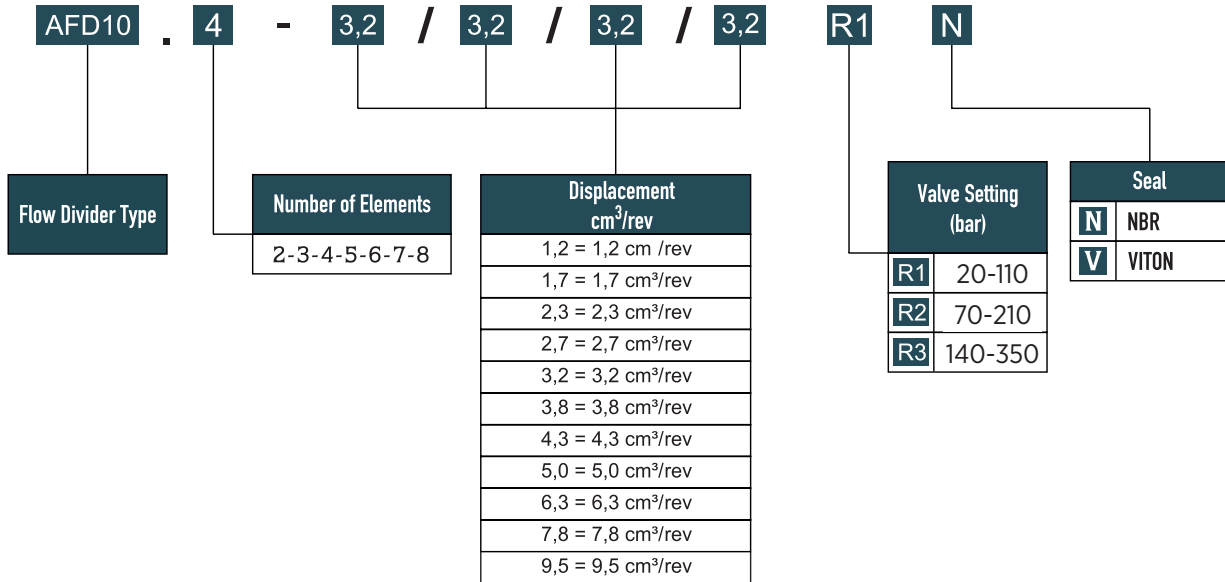

Code Example (Same displacement); AFD10.3-3,2N

Code Example (Different displacement); AFD10.3-3,2/2,7/2,3N

TECHNICAL DATA

Type	Displacement cm ³ /dev	Max. Pressure		ΔP bar	Max. Speed rpm	Min. Speed rpm	Min. Flow Rate l/min	Maks. Flow Rate l/min
		P1	P3					
	bar		bar					
AFD10.X.1,2N	1,2	220	280	40	3500	1200	1,5	4,2
AFD10.X.1,7N	1,7						2,0	6,0
AFD10.X.2,3N	2,3						2,8	8,0
AFD10.X.2,7N	2,7						3,2	9,5
AFD10.X.3,2N	3,2						3,8	10,8
AFD10.X.3,8N	3,8				4,6		11,4	
AFD10.X.4,3N	4,3				5,2		12,9	
AFD10.X.5,0N	5,0				6,0		15,0	
AFD10.X.6,3N	6,3				7,6		18,9	
AFD10.X.7,8N	7,8				9,4		23,4	
AFD10.X.9,5N	9,5	11,4	28,5					

P1: Continuous pressure

P3 : Peak pressure

MAX. FLOW FOR INLET SECTION
37,5 lt/dk (l/min)

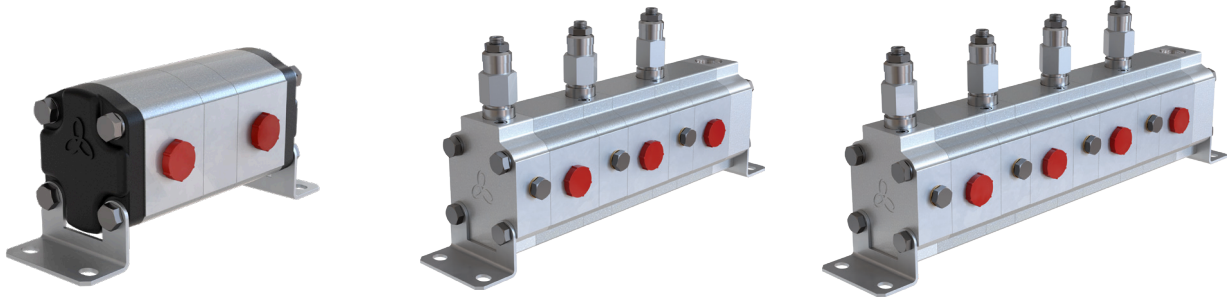

Tipi Type	cm ³ /rev	A	Giriş Inlet	Çıkış Outlet	(L) Boyu - Length						
					2	3	4	5	6	7	8
AFD20.X.4N	3,9	46,5	G 3/4"	G 1/2"	210,0	293,5	377,0	460,5	544,0	627,4	710,8
AFD20.X.6N	5,9	49,5			216,0	302,5	389,0	475,5	562,0	648,5	735,0
AFD20.X.8N	8,0	52,5			222,0	311,5	401,0	490,5	580,0	669,6	759,2
AFD20.X.9.5N	9,4	55,0			227,0	319,0	411,0	503,0	595,0	686,9	778,8
AFD20.X.11.5N	11,4	58,0			233,0	328,0	423,0	518,0	613,0	708,1	803,2
AFD20.X.14N	13,9	62,0			241,0	340,0	439,0	538,0	637,0	736,0	835,0
AFD20.X.16N	16,0	65,0			247,0	349,0	451,0	553,0	655,0	757,2	859,4
AFD20.X.19N	19,2	82,0			281,0	400,0	519,0	638,0	757,0	876,2	995,4
AFD20.X.22N	21,9	86,5			290,0	413,5	537,0	660,5	784,0	907,5	1031,0
AFD20.X.25N	24,8	91,6			300,0	429,0	557,5	686,0	815,0	943,6	1072,2
AFD20.X.28N	27,9	96,0			309,0	442,0	575,0	708,0	841,0	973,9	1106,9

Number of Elements	2	3	4	5	6	7	8
Number of Inlets	1	1	2	2	3	3	4

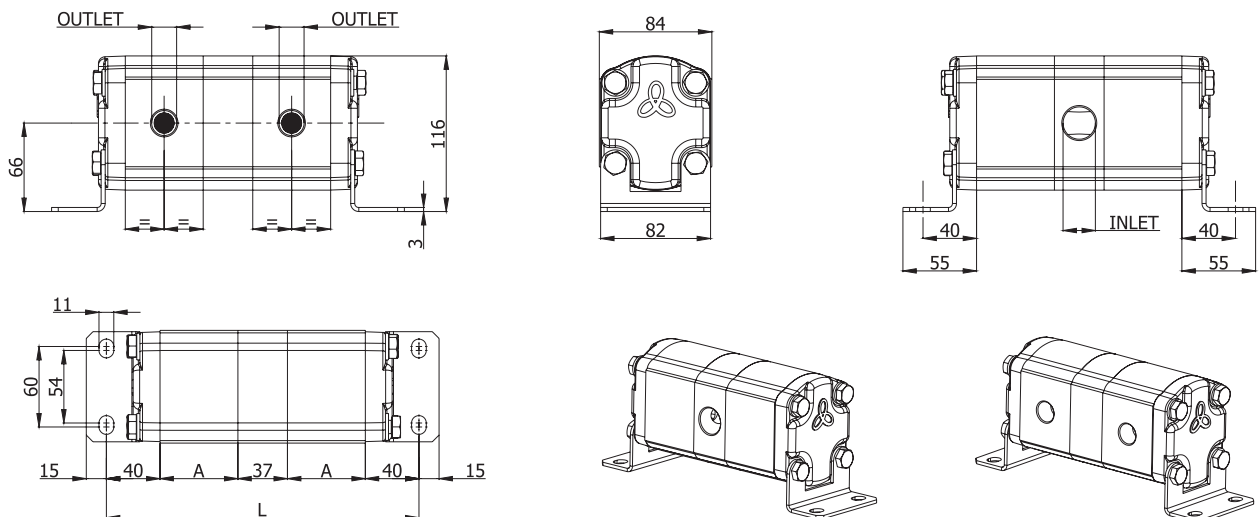

ORDERING CODE OF GROUP 20 FLOW DIVIDERS

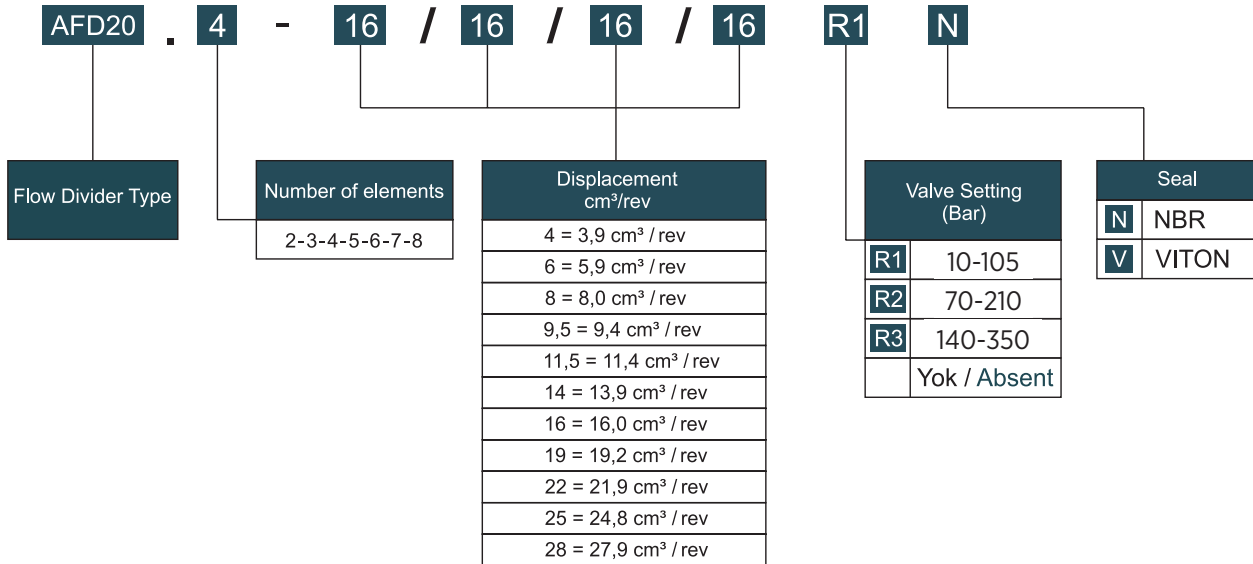

Code Example (Same displacement) ; AFD20.3-16N

Code Example (Different displacement) ; AFD20.3-16/14/11,5N

TECHNICAL DATA

Type	Displacement cm³/rev	Max. Pressure		ΔP bar	Max. Speed rpm	Min. Speed rpm	Min. Flow Rate l/min	Maks. Flow Rate l/min
		P1	P3					
		bar						
AFD20.X.4N	3,9	250	280	50	3000	1250	4,8	11,2
AFD20.X.6N	5,9						7,3	16,8
AFD20.X.8N	8,0						10,0	22,8
AFD20.X.9,5N	9,4						11,2	24,6
AFD20.X.11,5N	11,4	230	260	40	2750	1200	13,8	29,8
AFD20.X.14N	13,9						16,6	36,3
AFD20.X.16N	16,0						19,2	38,0
AFD20.X.19N	19,2	210	240	30	2500	1100	22,0	46,0
AFD20.X.22N	21,9	190	220				25,2	47,8
AFD20.X.25N	24,8	170	200				28,5	52,0
AFD20.X.28N	27,9	160	190				32,0	54,7

P1: Continuous pressure

P3 : Peak pressure

MAX. FLOW FOR INLET SECTION
80 lt/dk (l/min)



Type	Displacement cm ³ /rev	A	INLET	OUTLET	(L) Length							
					2	3	4	5	6	7	8	
AFD30.X-17N	17	75,1	G 1"	G 3/4"	320,2	455,3	590,4	725,5	860,6	995,7	1130,8	
AFD30.X-22N	22	79,1			328,2	467,3	606,4	745,5	884,6	1023,7	1162,8	
AFD30.X-27N	27	82,1	G 1 1/4"	G 1"	334,2	476,3	618,4	760,5	902,6	1044,7	1186,8	
AFD30.X-34N	34	86,1			342,2	488,3	634,4	780,5	926,6	1072,7	1218,8	
AFD30.X-38N	38	89,1			348,2	497,3	646,4	795,5	944,6	1093,7	1242,8	
AFD30.X-43N	43	92,1			354,2	506,3	658,4	810,5	962,6	1114,7	1266,8	
AFD30.X-47N	47	95,1			360,2	515,3	670,4	825,5	980,6	1135,7	1290,8	
AFD30.X-51N	51	97,1			364,2	521,3	678,4	835,5	992,6	1149,7	1306,8	
AFD30.X-56N	56	99,1			368,2	527,3	686,4	845,5	1004,6	1163,7	1322,8	
AFD30.X-61N	61	104,1			378,2	542,3	706,4	870,5	1034,6	1198,7	1362,8	
AFD30.X-73N	73	111,1			392,2	563,3	734,4	905,5	1076,6	1247,7	1418,8	
AFD30.X-82N	82	117,1			404,2	581,3	758,4	935,5	1112,6	1289,7	1466,8	
AFD30.X-90N	90	123,1	G 1 1/4"	G 1 1/4"	416,2	599,3	782,4	965,5	1148,6	1331,7	1514,8	
AFD30.X-100N	100	129,1			428,2	617,3	806,4	995,5	1184,6	1373,7	1562,8	

Number of elements	2	3	4	5	6	7	8
Number of inlets	1	1	2	2	3	3	4

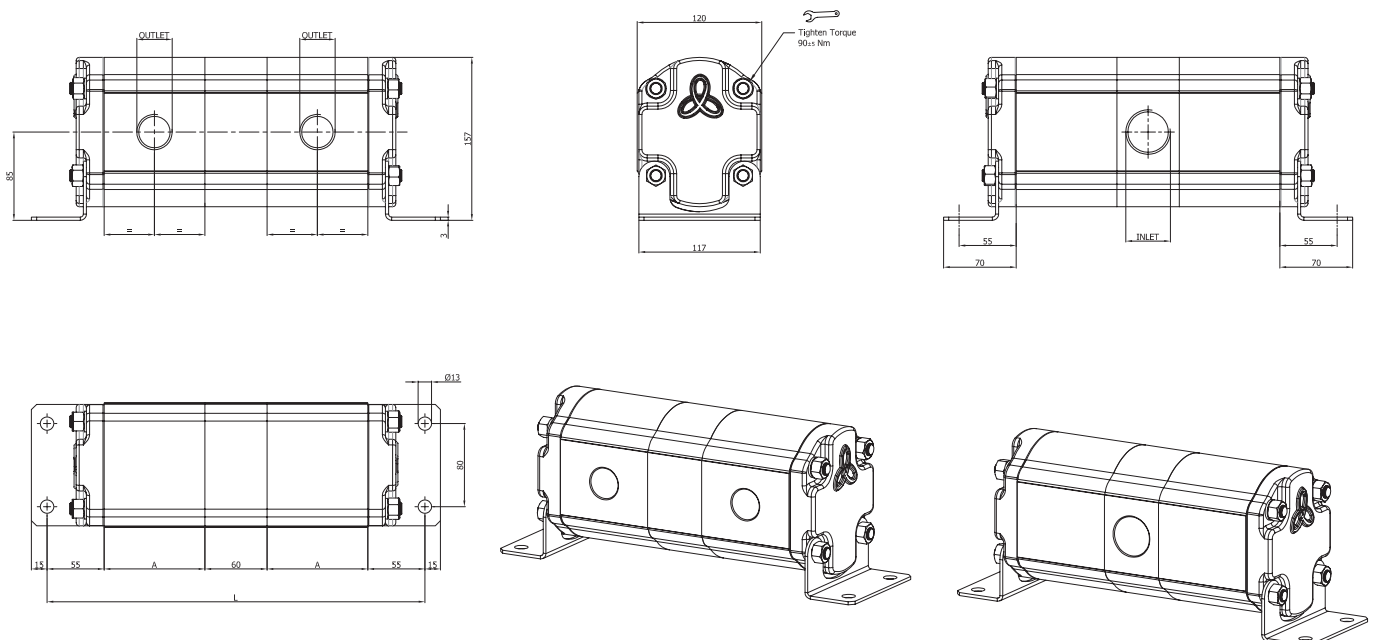

ORDERING CODE OF GROUP 30 FLOW DIVIDERS

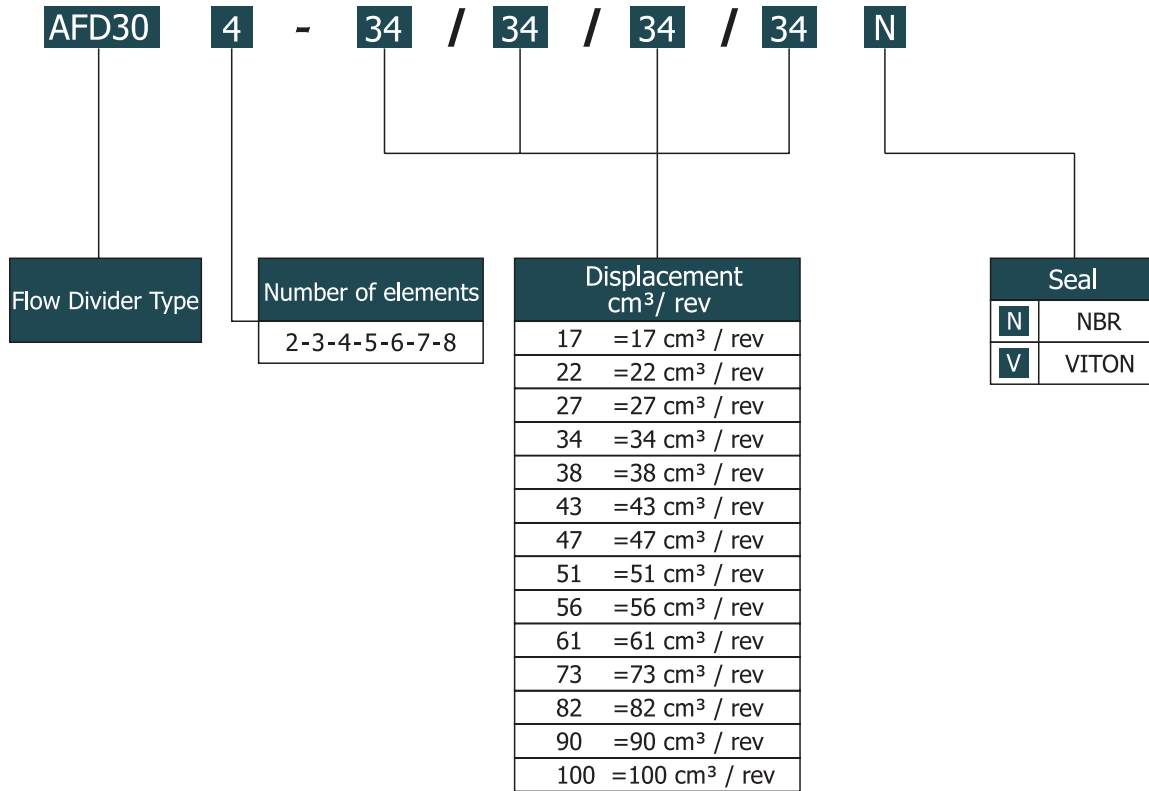

Code Example (Same displacement);AFD30.3-34N

Code Example (Different displacement);AFD30.3-34/27/22N

Type	Displacement cm ³ /rev	Max. pressure		ΔP (bar)	Max. Speed	Min. Speed	Min. Flow Rate l/min	Max. Flow Rate l/min
		P1	P3		rpm			
AFD30.X-17N	17	250	280	60	3000	1100	18,7	51,0
AFD30.X-22N	22						24,2	66,0
AFD30.X-27N	27						29,7	81,0
AFD30.X-34N	34	37,4	102,0					
AFD30.X-38N	38	41,8	114,0					
AFD30.X-43N	43	47,3	129,0					
AFD30.X-47N	47	47,0	117,5		2500	1000	51,0	127,5
AFD30.X-51N	51	210	240				56,0	140,0
AFD30.X-56N	56	200	230				61,0	152,5
AFD30.X-61N	61	180	210				65,7	146,0
AFD30.X-73N	73	170	200				73,8	164,0
AFD30.X-82N	82	160	190				81,0	180,0
AFD30.X-90N	90	150	180	2000	900	90,0	200,0	
AFD30.X-100N	100	140	170			90,0	200,0	

P1: Continuous pressure

P3 : Peak pressure

MAX. FLOW FOR EACH INLET SECTIONS	
G 1"	200 l/min
G 1 1/4"	360 l/min



Motor Type	Displacement (cm ³ /rev)	Max. Speed (rpm)	Max. Pressure (bar)	Max. Torque (Nm)	A	Weight (kg)
GMP.050.RDHG12EGN	52,9	755	140	98	143,5	5,6
GMP.080.RDHG12EGN	79,3	750	140	148	145	5,7
GMP.100.RDHG12EGN	98,2	610	140	183	147	5,9
GMP.125.RDHG12EGN	120,9	490	140	229	150	6,0
GMP.160.RDHG12EGN	158,7	375	140	295	155	6,2
GMP.200.RDHG12EGN	196,4	305	140	364	160	6,2
GMP.250.RDHG12EGN	241,8	245	110	370	166	6,6
GMP.315.RDHG12EGN	317,3	185	90	375	176	6,9
GMP.400.RDHG12EGN	392,9	150	70	360	186	7,4

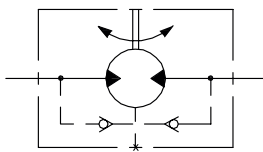
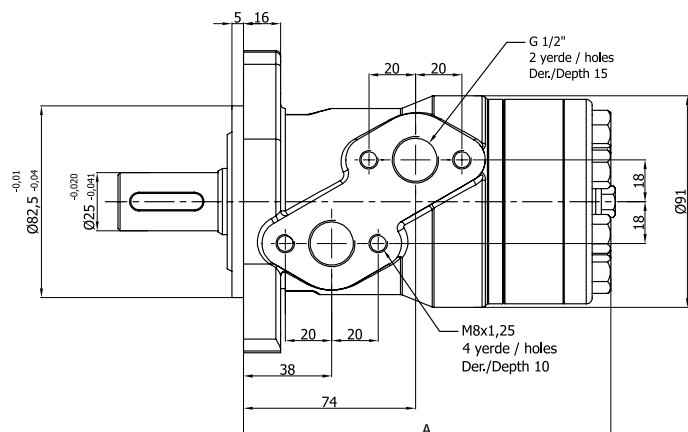
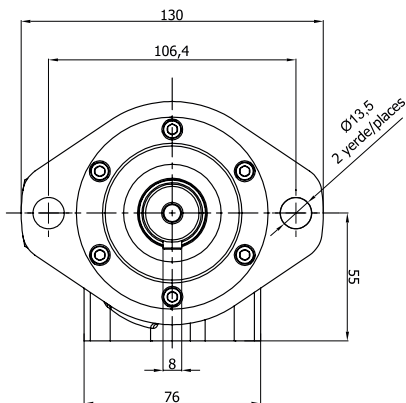
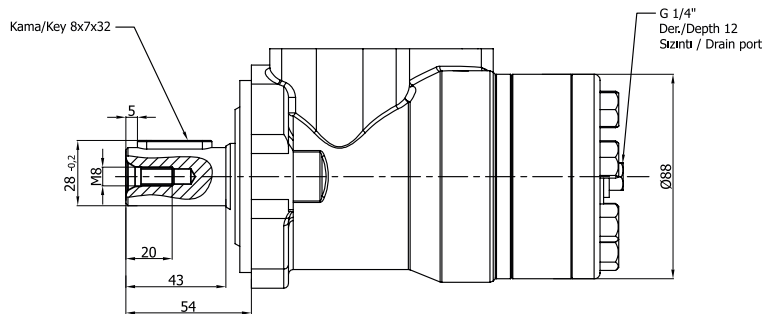

CIRCUIT DIAGRAM

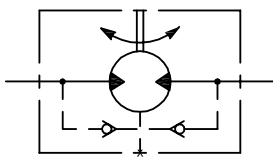

Motor Type	Displacement (cm ³ /rev)	Max. Speed (rpm)	Max. Pressure (bar)	Max. Torque (Nm)	A	Weight (kg)
GMR.032.RDHG12EGN	32,5	1230	100	40	142	6,2
GMR.050.RDHG12EGN	51,7	770	140	100	143	6,5
GMR.080.RDHG12EGN	80,5	745	140	155	148	6,9
GMR.100.RDHG12EGN	100,5	595	140	195	151,5	7,0
GMR.125.RDHG12EGN	126,3	475	140	240	156	7,3
GMR.160.RDHG12EGN	160,8	370	140	310	162	7,5
GMR.200.RDHG12EGN	200,9	295	140	370	169	8,0
GMR.250.RDHG12EGN	252,6	235	120	395	178	8,5
GMR.315.RDHG12EGN	321,5	185	100	415	190	9,0
GMR.400.RDHG12EGN	401,9	150	80	415	204	11,0

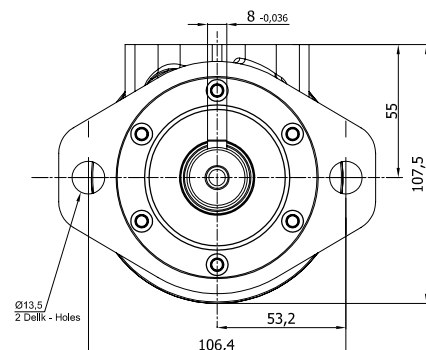
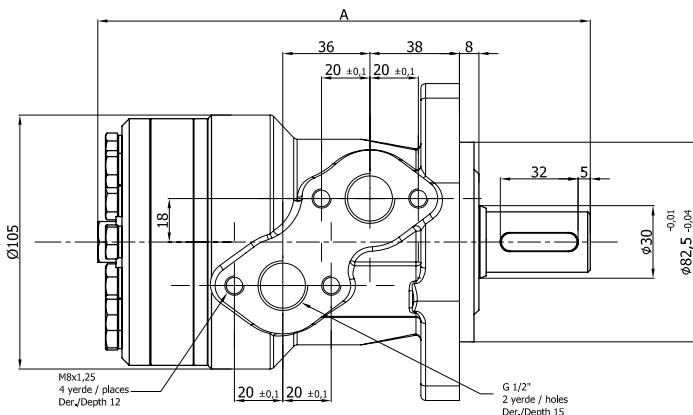
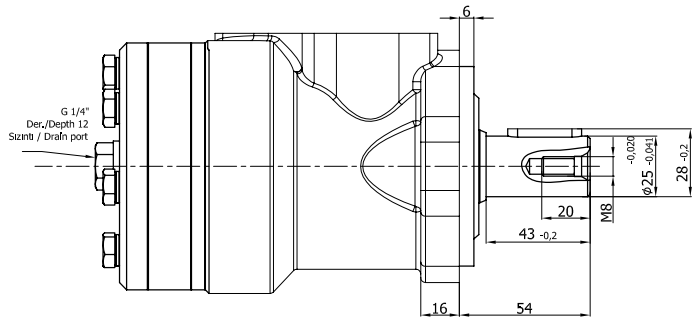

CIRCUIT DIAGRAM





Motor Type	Displacement (cm ³ /rev)	Max. Speed (rpm)	Max. Pressure (bar)	Max. Torque (Nm)	A	Weight (kg)
GMH.200.RVLG12EGN	203,0	365	160	425	168	10,5
GMH.250.RVLG12EGN	253,7	295	160	530	175	11,0
GMH.315.RVLG12EGN	318,9	235	150	610	184	11,5
GMH.400.RVLG12EGN	405,9	180	140	825	196	12,5
GMH.500.RVLG12EGN	471,1	155	120	720	205	13,0

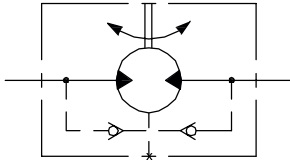

CIRCUIT DIAGRAM

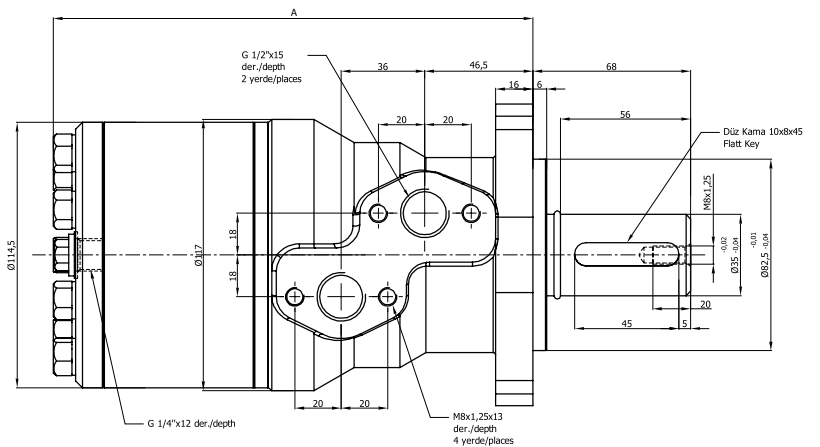
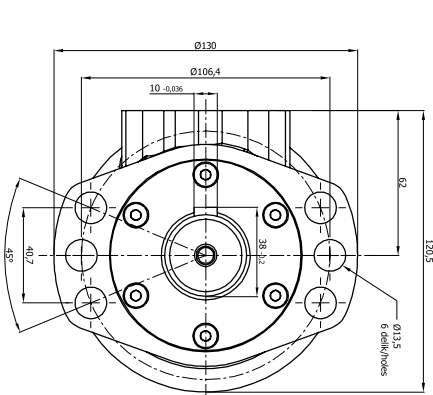



Motor Type	Displacement (cm ³ /rev)	Max. Speed (rpm)	Max. Pressure (bar)	Max. Torque (Nm)	A	B	Weight (kg)
GMS.080.RNPG12EGN	80,5	805	205	226	147,5	170,0	9,8
GMS.100.RNPG12EGN	100,5	745	205	282	151,0	173,5	10,0
GMS.125.RNPG12EGN	126,3	590	205	355	155,5	178,0	10,3
GMS.160.RNPG12EGN	160,8	465	205	451	161,5	184,0	10,7
GMS.200.RNPG12EGN	200,9	370	205	564	168,5	191,0	11,1
GMS.250.RNPG12EGN	252,6	295	200	684	177,5	200,0	11,6
GMS.315.RNPG12EGN	321,5	230	200	870	189,5	212,0	12,3
GMS.400.RNPG12EGN	401,9	185	155	813	203,5	226,0	13,2
GMS.500.RNPG12EGN	476,5	155	120	728	216,5	239,0	14,3

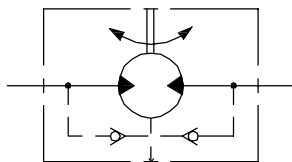

CIRCUIT DIAGRAM

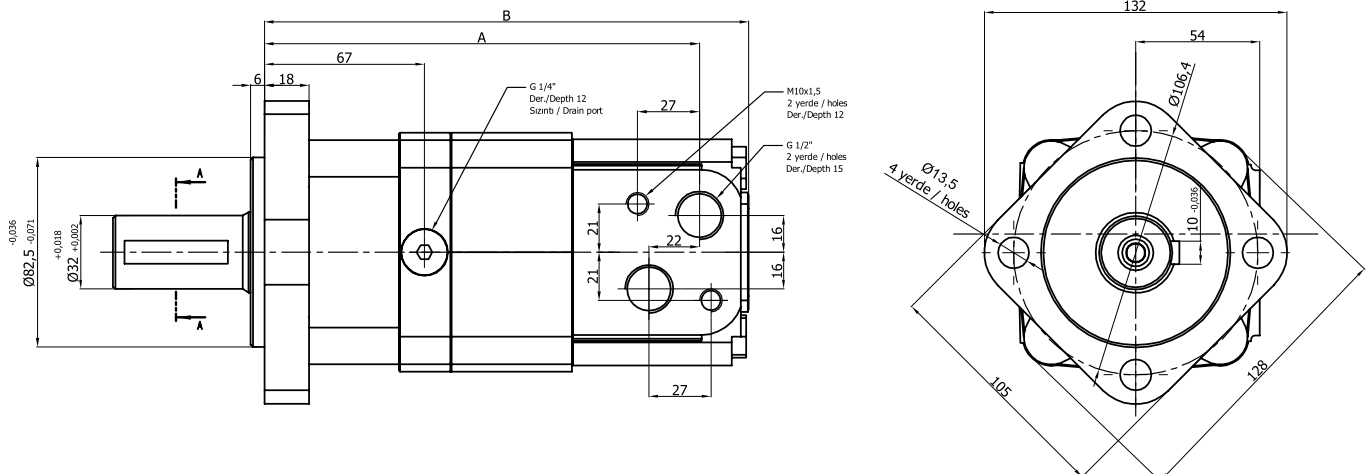
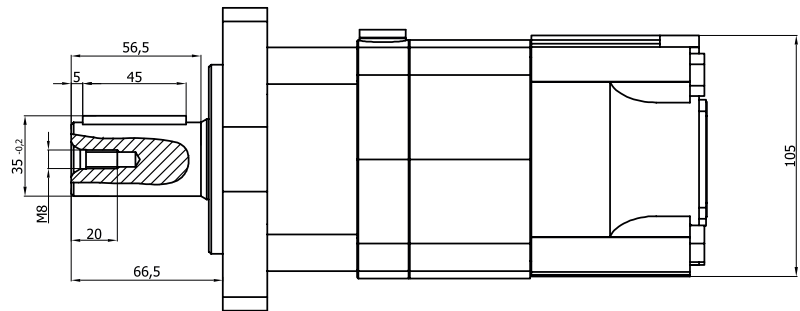



Motor Type	Displacement (cm ³ /rev)	Max. Speed (rpm)	Max. Pressure (bar)	Max. Torque (Nm)	A	Weight (kg)
GMT.160.RN1H1G34EGN	158,8	625	240	559	205,5	20,3
GMT.200.RN1H1G34EGN	200,8	495	240	714	210,0	20,8
GMT.250.RN1H1G34EGN	252,2	395	240	883	215,5	21,4
GMT.315.RN1H1G34EGN	317,5	310	230	1095	222,5	22,4
GMT.400.RN1H1G34EGN	401,6	245	210	1255	231,5	23,0
GMT.500.RN1H1G34EGN	535,3	185	180	1377	250,0	24,0

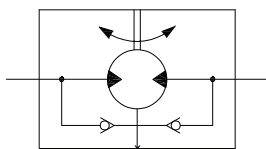

CIRCUIT DIAGRAM

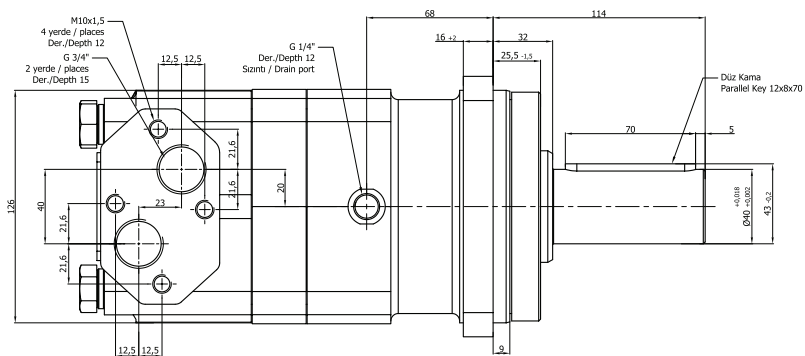
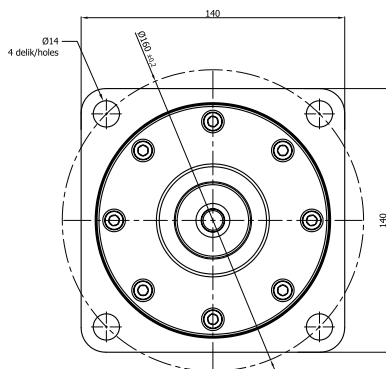
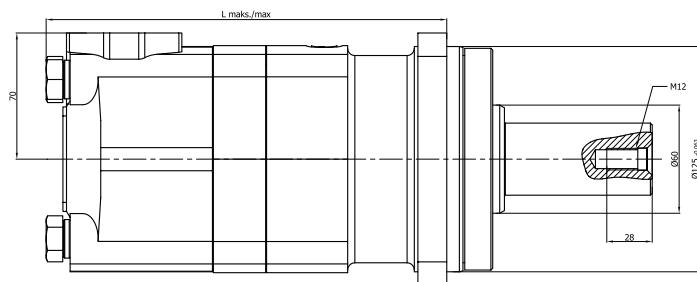

The Future of
Hydraulic Power

 **blue**
ascend
hydraulics

Konya Organize San. Böl. Evrenköy Cd.
No: 31 Selçuklu - Konya / TÜRKİYE
Tel: +90 332 **239 25 41** (3 line)
Fax: +90 332 **239 25 44**
info@ascendustri.com

blueascend.com

