

让动力来得更简单！ Make Power More Accessible



微信公众号
WeChat official account



官方网站平台
Official website platform

安徽航瑞航空动力装备有限公司
Anhui Haery Aviation Power Co.,Ltd

(2024版)

公司主页 (Homepage) : www.haerypower.com
联系电话 (Contact number) : 0553-7568816
客户服务呼叫中心 (Call center) : 400-006-6626
公司传真 (Fax) : 0553-7568794
公司地址 (Add) : 安徽省芜湖市湾沚区阳光大道2866号
2866 Sunshine Avenue, Wanzhi Zone, Wuhu city, Anhui Province, China.



安徽航瑞航空动力装备有限公司
Anhui Haery Aviation Power Co., Ltd

让动力来得更简单 Make Power More Accessible

www.haerypower.com

DV210 柴油发动机 (36.8-60kW)

DV210 diesel engine (36.8-60kW)

主要产品特征 MAIN PRODUCT FEATURES

- V型2缸/4冲程/液冷/柴油发动机;
V2, 4-stroke, Liquid-cooled, Diesel engine;
- 电控高压共轨系统;
Electronic control high pressure common rail system;
- 低惯量涡轮增压器技术、高速扭矩大;
Low inertia turbocharger technology, High speed with high torque
- 满足非道路国三、国四阶段排放法规;
Meet the regulations on Non-road diesel mobile machinery (CHINA III, IV)
- 高可靠性、低油耗、低振动等特点;
With the characteristics of high reliability, Low fuel consumption, Low vibration;



产品型号 Product models	麋鹿 Elk DV210		麋鹿 Elk DV210F
型式 Configuration	V型2缸、液冷、4冲程、电控、增压中冷、高压共轨 V2, Liquid-cooled, 4-stroke, EFI, TCI, High pressure Common rail		
气缸套型式 Cylinder liner type	一体式 All-in-one		
缸径*行程(mm) Bore*stroke	86×86		
排量(L) Displacement	0.999		
额定功率/转速(kw/rpm) Rated power/Speed	36.8 / 3200	42 / 3600	60 / 3800
最大扭矩点燃油消耗率(g/kw·h) BSFC at maximum torque	≤235		≤230
稳态转速波动率(%) Steady-state speed volatility	≤0.2		
转速恢复时间(s) Speed recovery time	≤3		
启动方式 Startup mode	12V / 24V		
整机质量(kg) Weight	96	97	
外形尺寸L×W×H(mm) Overall dimension	491x645x539		516x639x571
主要用途 Applications	无人车、无人船、发电机组、工程机械 Driverless car, Unmanned ship, Generator set, Construction machinery		

外形尺寸图 OUTLINE DRAWING

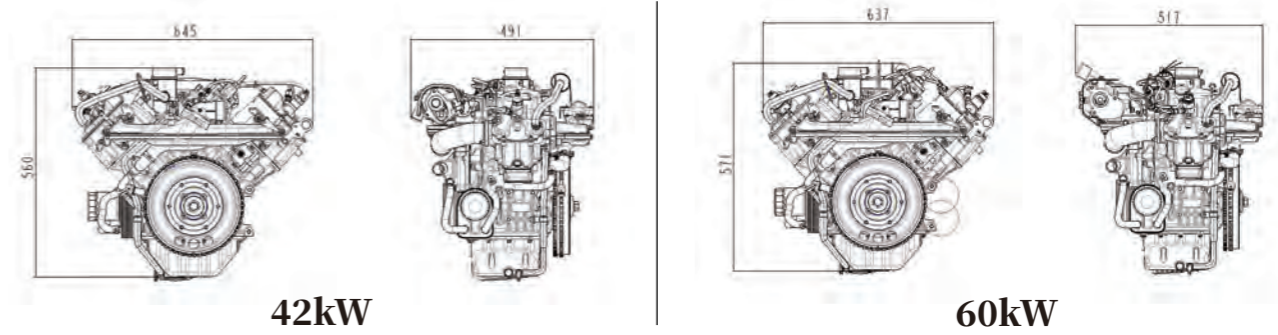

特性曲线 CHARACTERISTIC CURVE

功率曲线 Power curve

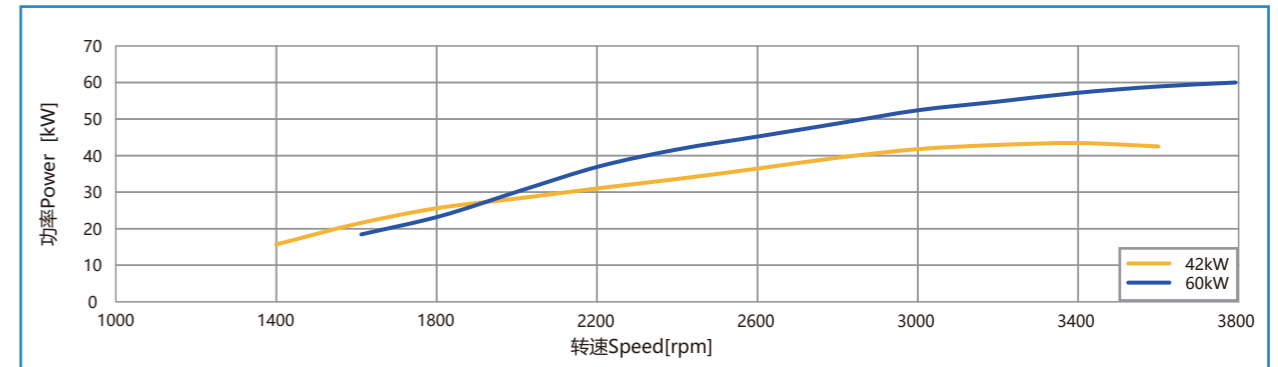

扭矩曲线 Torque curve

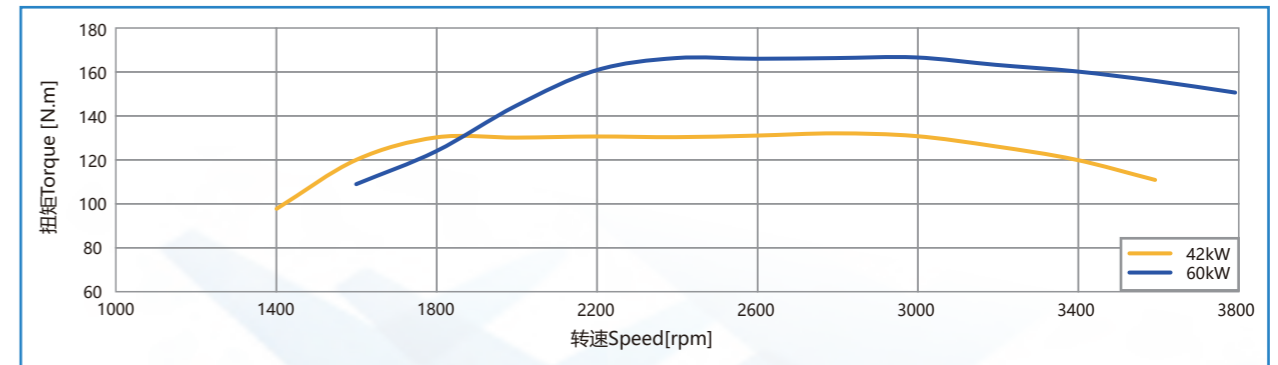

油耗曲线 BSFC

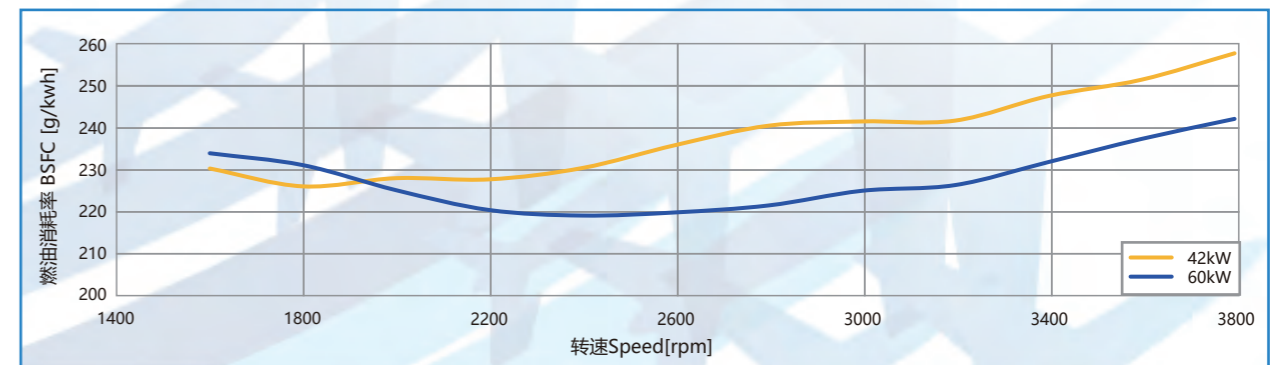

以上性能参数均按照 ISA 各海拔标准环境测量。(地面环境温度: 25±2°C, 中冷后温度: 50±2°C)