

JOVVOO

Z08TSL

8m自调平履带剪叉式高空作业平台
8m Bi-Levelling Tracked Scissor Lifts

结构紧凑

Compact Structure

安全装置齐全

Complete Safety Device

越野能力出色

Excellent Off-road Performance

续航能力强

Strong Battery Life



技术参数 (Technical Parameters)

型号 Models	Z08TSL
最大工作高度 Max. Working Height	10.3m
最大平台高度 Platform Height-Raised	8.3m
平台尺寸 Platform Dimensions (L*W*H)	2.28×1.136×1.26m
A 整车长度 Overall Length	2.53m
B 整车宽度 Overall Width	1.37m
C 整机高度(围栏未折叠) Overall Height-Guardrails Up	2.835m
整机高度(围栏折叠) Overall Height-Guardrails Down	2.327m
平台延伸尺寸 Extension Deck	0.9m
轴距 Wheelbase	1.8m
性能 Productivity	
安全工作载荷 Platform Capacity	250kg
延伸平台安全工作载荷 Platform Capacity-Extension Deck	113.3kg
最大工作人数 Max. Platform Occupants	2
高速行驶状态 High Driving Speed	2~3km/h
低速行驶状态 Low Driving Speed	0.8~1.2km/h
最大爬坡能力(收起) Gradeability-Stowed	36%
升降速度-举升 Lifting Speed-Raise	6~8m/min
升降速度-下降 Lifting Speed-Lower	10~12m/min
纵向调平角度-前侧 Longitudinal Leveling Front	±15°
纵向调平角度-后侧 Longitudinal Leveling Rear	±20°
横向调平角度 Lateral Leveling	±17°
动力 Power	
电池 Battery	8×6V/200Ah
充电器 Charger	30A
液压系统 Hydraulic System	
液压油容量 Hydraulic Oil Capacity	32L
重量 Weight	
整机重量 Machine Weight	3398kg

标准功能 Standard Features

比例控制 Proportional control	可折叠护栏 Foldable guardrail
手动制动器释放 Manual brake release	室内室外适用 Indoor and outdoor rated
紧急停止装置 Emergency stop device	动作报警 All motions alarm
紧急下降 Emergency descent	倾斜保护系统 Tilt alarm with lift cut-out
自锁式入口闸门 Self-lock entry gate	工作指示灯 Descent alarm with flashing beacon
全高驱动器 Full-height drive	智能诊断系统 Intelligent diagnostic system
过载感应系统 Overload sensing system	免维护电池 Maintenance-free batteries

选配 Optional

交流电源平台 AC power to platform	远程通信 Telematics
防碰撞保护 Anti-collision protection	可生物降解液压油 Biodegradable hydraulic oil
锂电池 Lithium battery	过载报警 Overload alarm
GPS远程定位 GPS remote positioning	

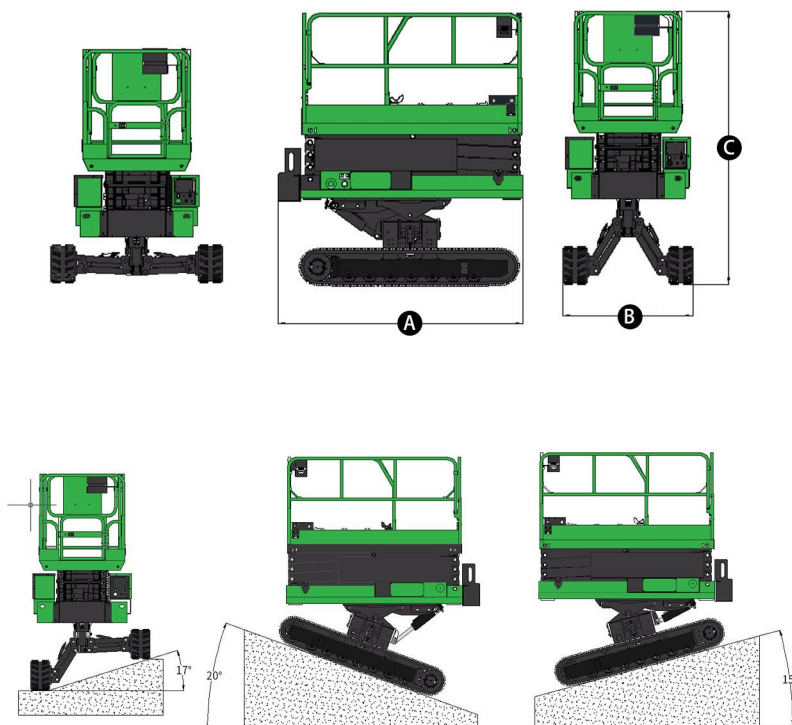

玖伍智能科技有限公司 Jovoo Industries Inc.

地址(Add): 山东省济南市济阳区济北开发区仁和街13号

No.13, Renhe Street, Jibei Development Zone, Jinan, China

电话(Phone): +86 198 5310 4505

邮箱(Email): contact@jovoolift.com

网址(Website): www.jovoolift.com



JOVVOO

Z10TSL

10m自调平履带剪叉式高空作业平台
10m Bi-Levelling Tracked Scissor Lifts

结构紧凑

Compact Structure

安全装置齐全

Complete Safety Device

越野能力出色

Excellent Off-road Performance

续航能力强

Strong Battery Life



技术参数 (Technical Parameters)

型号 Models	Z10TSL
最大工作高度 Max. Working Height	12m
最大平台高度 Platform Height-Raised	10m
平台尺寸 Platform Dimensions (L*W*H)	2.28×1.136×1.26m
Ⓐ 整车长度 Overall Length	2.53m
Ⓑ 整车宽度 Overall Width	1.37m
Ⓒ 整机高度(围栏未折叠) Overall Height-Guardrails Up	2.965m
整机高度(围栏折叠) Overall Height-Guardrails Down	2.457m
平台延伸尺寸 Extension Deck	0.9m
轴距 Wheelbase	1.8m
性能 Productivity	
安全工作载荷 Platform Capacity	250kg
延伸平台安全工作载荷 Platform Capacity-Extension Deck	113.3kg
最大工作人数 Max. Platform Occupants	2
高速行驶状态 High Driving Speed	2~3km/h
低速行驶状态 Low Driving Speed	0.8~1.2km/h
最大爬坡能力(收起) Gradeability-Stowed	36%
升降速度-举升 Lifting Speed-Raise	6~8m/min
升降速度-下降 Lifting Speed-Lower	10~12m/min
纵向调平角度-前侧 Longitudinal Leveling Front	±15°
纵向调平角度-后侧 Longitudinal Leveling Rear	±20°
横向调平角度 Lateral Leveling	±17°
动力 Power	
电池 Battery	8×6V/200Ah
充电器 Charger	30A
液压系统 Hydraulic System	
液压油容量 Hydraulic Oil Capacity	32L
重量 Weight	
整机重量 Machine Weight	3698kg

标准功能 Standard Features

比例控制 Proportional control	可折叠护栏 Foldable guardrail
手动制动器释放 Manual brake release	室内室外适用 Indoor and outdoor rated
紧急停止装置 Emergency stop device	动作报警 All motions alarm
紧急下降 Emergency descent	倾斜保护系统 Tilt alarm with lift cut-out
自锁式入口闸门 Self-lock entry gate	工作指示灯 Descent alarm with flashing beacon
全高驱动器 Full-height drive	智能诊断系统 Intelligent diagnostic system
过载感应系统 Overload sensing system	免维护电池 Maintenance-free batteries

选配 Optional

交流电源平台 AC power to platform	远程通信 Telematics
防碰撞保护 Anti-collision protection	可生物降解液压油 Biodegradable hydraulic oil
锂电池 Lithium battery	过载报警 Overload alarm
GPS远程定位 GPS remote positioning	

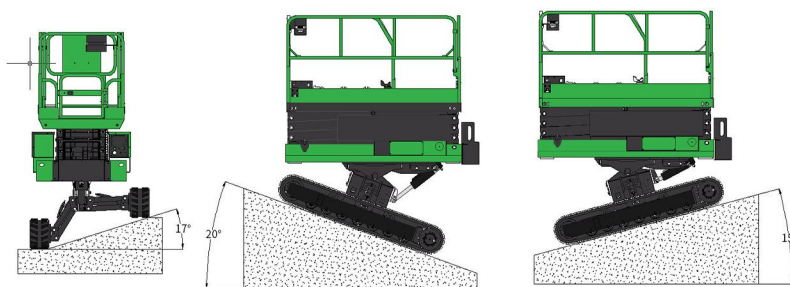
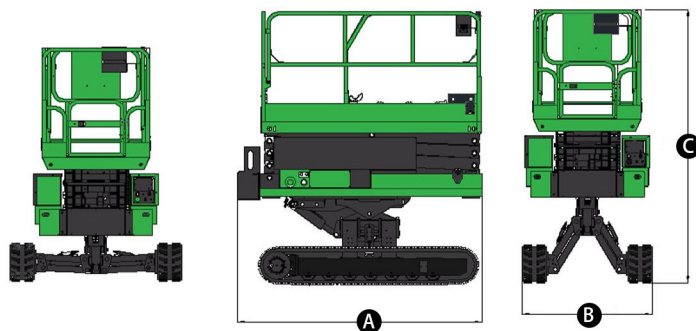

玖伍智能科技有限公司 Jovoo Industries Inc.

地址(Add): 山东省济南市济阳区济北开发区仁和街13号

No.13, Renhe Street, Jibei Development Zone, Jinan, China

电话(Phone): +86 198 5310 4505

邮箱(Email): contact@jovoolift.com

网址(Website): www.jovoolift.com



JOVVOO

Z12TSL

12m自调平履带剪叉式高空作业平台
12m Bi-Levelling Tracked Scissor Lifts

结构紧凑

Compact Structure

安全装置齐全

Complete Safety Device

越野能力出色

Excellent Off-road Performance

续航能力强

Strong Battery Life



技术参数 (Technical Parameters)

型号 Models	Z12TSL
最大工作高度 Max. Working Height	14m
最大平台高度 Platform Height-Raised	12m
平台尺寸 Platform Dimensions (L*W*H)	2.28×1.136×1.26m
Ⓐ 整车长度 Overall Length	2.53m
Ⓑ 整车宽度 Overall Width	1.37m
Ⓒ 整机高度(围栏未折叠) Overall Height-Guardrails Up	3.095m
整机高度(围栏折叠) Overall Height-Guardrails Down	2.587m
平台延伸尺寸 Extension Deck	0.9m
轴距 Wheelbase	1.8m
性能 Productivity	
安全工作载荷 Platform Capacity	250kg
延伸平台安全工作载荷 Platform Capacity-Extension Deck	113.3kg
最大工作人数 Max. Platform Occupants	2
高速行驶状态 High Driving Speed	2~3km/h
低速行驶状态 Low Driving Speed	0.8~1.2km/h
最大爬坡能力(收起) Gradeability-Stowed	36%
升降速度-举升 Lifting Speed-Raise	6~8m/min
升降速度-下降 Lifting Speed-Lower	10~12m/min
纵向调平角度-前侧 Longitudinal Leveling Front	±15°
纵向调平角度-后侧 Longitudinal Leveling Rear	±20°
横向调平角度 Lateral Leveling	±17°
动力 Power	
电池 Battery	8×6V/200Ah
充电器 Charger	30A
液压系统 Hydraulic System	
液压油容量 Hydraulic Oil Capacity	32L
重量 Weight	
整机重量 Machine Weight	3998kg

标准功能 Standard Features

比例控制 Proportional control	可折叠护栏 Foldable guardrail
手动制动器释放 Manual brake release	室内室外适用 Indoor and outdoor rated
紧急停止装置 Emergency stop device	动作报警 All motions alarm
紧急下降 Emergency descent	倾斜保护系统 Tilt alarm with lift cut-out
自锁式入口闸门 Self-lock entry gate	工作指示灯 Descent alarm with flashing beacon
全高驱动器 Full-height drive	智能诊断系统 Intelligent diagnostic system
过载感应系统 Overload sensing system	免维护电池 Maintenance-free batteries

选配 Optional

交流电源平台 AC power to platform	远程通信 Telematics
防碰撞保护 Anti-collision protection	可生物降解液压油 Biodegradable hydraulic oil
锂电池 Lithium battery	过载报警 Overload alarm
GPS远程定位 GPS remote positioning	

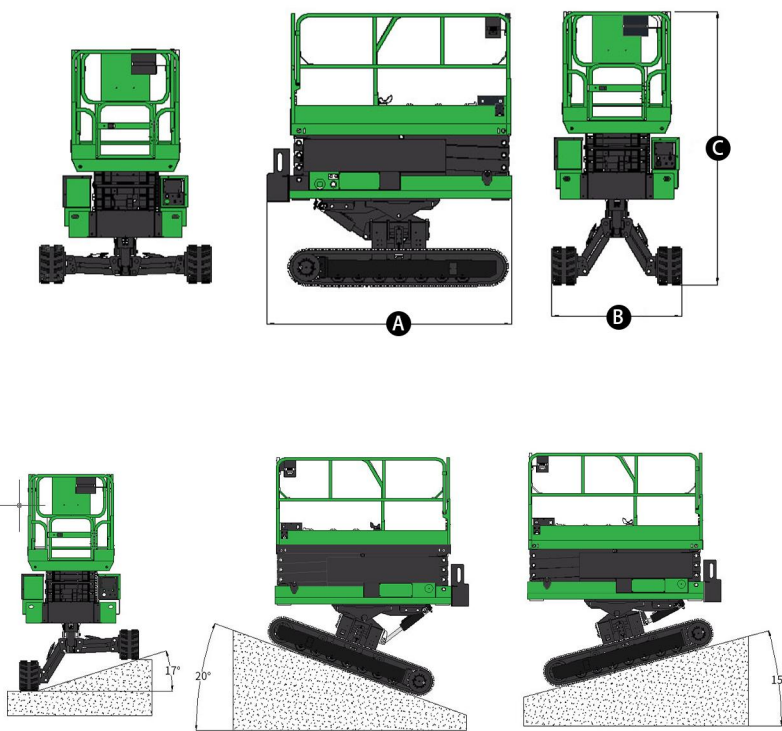

玖伍智能科技有限公司
Jovoo Industries Inc.

地址(Add): 山东省济南市济阳区济北开发区仁和街13号

No.13, Renhe Street, Jibei Development Zone, Jinan, China

电话(Phone): +86 198 5310 4505

邮箱(Email): contact@jovoolift.com

网址(Website): www.jovoolift.com

