

JOVVOO

Z06N

HYDRAULIC MOTOR DRIVE
SCISSOR LIFT

- Compact Structure
- Complete Safety Device
- Large Working Range
- Strong Battery Life



技术参数 (Technical Parameters)

型号 Models	Z06N
最大工作高度 Max. Working Height	7.8m
Ⓐ 最大平台高度 Platform Height-Raised	5.8m
Ⓑ 平台长度 Platform Length	1.68m
Ⓒ 平台宽度 Platform Width	0.74m
Ⓓ 整车长度 Overall Length	1.85m
Ⓔ 整车宽度 Overall Width	0.79m
Ⓕ 整机高度(围栏未折叠) Overall Height-Guardrails Up	2.2m
Ⓖ 整机高度(围栏折叠) Overall Height-Guardrails Down	1.67m
Ⓗ 平台延伸尺寸 Extension Deck	0.9m
Ⓘ 轴距 Wheelbase	1.36m
离地间隙 (收起/升起) Ground Clearance(Stowed/Raised)	0.083m/0.016m

性能 Productivity	
最大工作人数 Max. Platform Occupants	2
安全工作载荷 Platform Capacity	230kg
延伸平台安全工作载荷 Platform Capacity-Extension Deck	113kg
行驶高度 Drive Height	高空行驶
最大爬坡能力(收起) Gradeability-Stowed	25%
内侧/外侧转弯半径 Turning Radius-Inside/Outside	0/1.67m
提升/降低速度 Raise/Lower Speed	3-5m/min
驱动模式 Drive Mode	4x2
轮胎类型 Tire Type	实心无痕轮胎
轮胎尺寸 Tire Size	φ305×100mm

动力 Power	
电池 Battery	24V/200Ah
充电器 Charger	24V/36A

液压系统 Hydraulic System	
液压油容量 Hydraulic Oil Capacity	6L

重量 Weight	
整机重量 Machine Weight	1430kg

标准功能 Standard Features	
比例控制 Proportional control	可折叠护栏 Foldable guardrail
手动制动器释放 Manual brake release	室内室外适用 Indoor and outdoor rated
紧急停止装置 Emergency stop device	旋出元件托盘 Swing-out component tray
紧急下降 Emergency descent	坑洞防护装置 Pothole guard
自锁式入口闸门 Self-lock entry gate	动作报警 All motions alarm
全高驱动器 Full-height drive	倾斜保护系统 Tilt alarm with lift cut-out
过载感应系统 Overload sensing system	工作指示灯 Descent alarm with flashing beacon
智能诊断系统 Intelligent diagnostic system	实心无痕轮胎 Solid non-marking tires
免维护电池 Maintenance-free batteries	

选配 Optional	
交流电源平台 AC power to platform	远程通信 Telematics
防撞保护 Anti-collision protection	可生物降解液压油 Biodegradable hydraulic oil
锂电池 Lithium battery	过载报警 Overload alarm
GPS远程定位 GPS remote positioning	

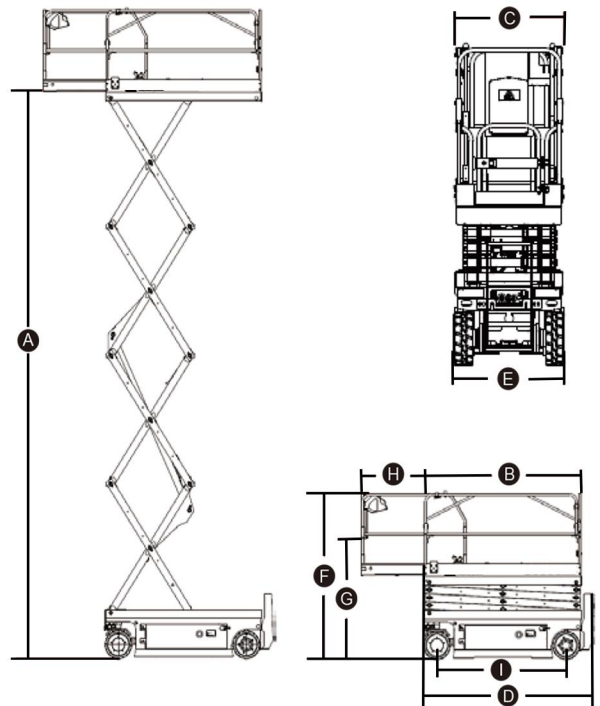

玖伍智能科技有限公司 Jovoo Industries Inc.

地址(Add): 山东省济南市济阳区济北开发区仁和街13号
No.13, Renhe Street, Jibei Development Zone, Jinan, China

电话(Phone): +86 198 5310 4505

邮箱(Email): contact@jovoolift.com

网址(Website): www.jovoolift.com



JOVVOO

Z06W

HYDRAULIC MOTOR DRIVE
SCISSOR LIFT

- Compact Structure
- Complete Safety Device
- Large Working Range
- Strong Battery Life



技术参数 (Technical Parameters)

型号 Models	Z06W
最大工作高度 Max. Working Height	7.8m
A 最大平台高度 Platform Height-Raised	5.8m
B 平台长度 Platform Length	2.27m
C 平台宽度 Platform Width	1.12m
D 整车长度 Overall Length	2.43m
E 整车宽度 Overall Width	1.21m
F 整机高度(围栏未折叠) Overall Height-Guardrails Up	2.22m
G 整机高度(围栏折叠) Overall Height-Guardrails Down	1.67m
H 平台延伸尺寸 Extension Deck	0.9m
I 轴距 Wheelbase	1.87m
离地间隙 (收起/升起) Ground Clearance(Stowed/Raised)	0.11m/0.02m

性能 Productivity	
最大工作人数 Max. Platform Occupants	2
安全工作载荷 Platform Capacity	450kg
延伸平台安全工作载荷 Platform Capacity-Extension Deck	113kg
行驶高度 Drive Height	高空行驶
最大爬坡能力(收起) Gradeability-Stowed	25%
内侧/外侧转弯半径 Turning Radius-Inside/Outside	0/2.1m
提升/降低速度 Raise/Lower Speed	3-5m/min
驱动模式 Drive Mode	4x2
轮胎类型 Tire Type	实心无痕轮胎
轮胎尺寸 Tire Size	φ381×127mm

动力 Power	
电池 Battery	24V/200Ah
充电器 Charger	24V/36A

液压系统 Hydraulic System	
液压油容量 Hydraulic Oil Capacity	6L

重量 Weight	
整机重量 Machine Weight	2250kg

标准功能 Standard Features	
比例控制 Proportional control	可折叠护栏 Foldable guardrail
手动制动器释放 Manual brake release	室内室外适用 Indoor and outdoor rated
紧急停止装置 Emergency stop device	旋出元件托盘 Swing-out component tray
紧急下降 Emergency descent	坑洞防护装置 Pothole guard
自锁式入口闸门 Self-lock entry gate	动作报警 All motions alarm
全高驱动器 Full-height drive	倾斜保护系统 Tilt alarm with lift cut-out
过载感应系统 Overload sensing system	工作指示灯 Descent alarm with flashing beacon
智能诊断系统 Intelligent diagnostic system	实心无痕轮胎 Solid non-marking tires
免维护电池 Maintenance-free batteries	

选配 Optional	
交流电源平台 AC power to platform	远程通信 Telematics
防碰撞保护 Anti-collision protection	可生物降解液压油 Biodegradable hydraulic oil
锂电池 Lithium battery	过载报警 Overload alarm
GPS远程定位 GPS remote positioning	

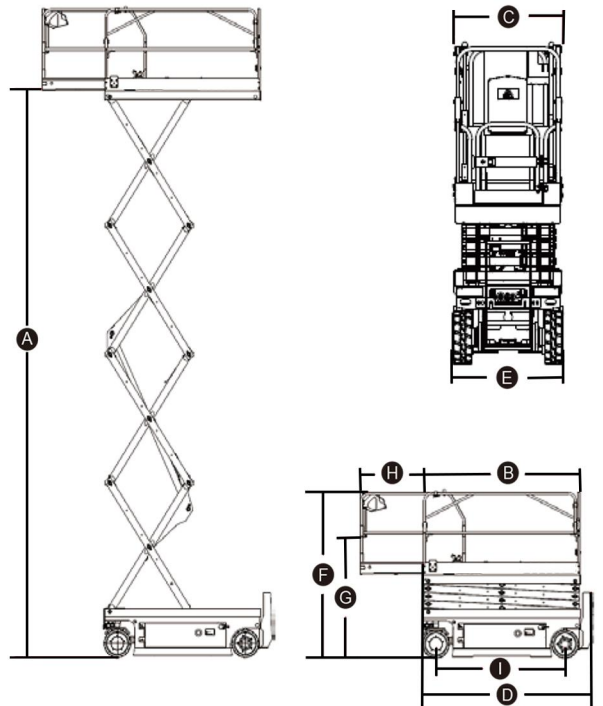

玖伍智能科技有限公司 Jovoo Industries Inc.

地址(Add): 山东省济南市济阳区济北开发区仁和街13号

No.13, Renhe Street, Jibei Development Zone, Jinan, China

电话(Phone): +86 198 5310 4505

邮箱(Email): contact@jovoolift.com

网址(Website): www.jovoolift.com



JOVVOO

Z08N

HYDRAULIC MOTOR DRIVE
SCISSOR LIFT

- Compact Structure
- Complete Safety Device
- Large Working Range
- Strong Battery Life



技术参数 (Technical Parameters)

型号 Models	Z08N
最大工作高度 Max. Working Height	9.8m
A 最大平台高度 Platform Height-Raised	7.8m
B 平台长度 Platform Length	2.27m
C 平台宽度 Platform Width	0.86m
D 整车长度 Overall Length	2.43m
E 整车宽度 Overall Width	0.89m
F 整机高度(围栏未折叠) Overall Height-Guardrails Up	2.35m
G 整机高度(围栏折叠) Overall Height-Guardrails Down	1.9m
H 平台延伸尺寸 Extension Deck	0.9m
I 轴距 Wheelbase	1.87m
离地间隙 (收起/升起) Ground Clearance(Stowed/Raised)	0.11m/0.02m

性能 Productivity	
最大工作人数 Max. Platform Occupants	2
安全工作载荷 Platform Capacity	320kg
延伸平台安全工作载荷 Platform Capacity-Extension Deck	113kg
行驶高度 Drive Height	高空行驶
最大爬坡能力(收起) Gradeability-Stowed	25%
内侧/外侧转弯半径 Turning Radius-Inside/Outside	0/2.1m
提升/降低速度 Raise/Lower Speed	3-5m/min
驱动模式 Drive Mode	4x2
轮胎类型 Tire Type	实心无痕轮胎
轮胎尺寸 Tire Size	φ381×127mm

动力 Power	
电池 Battery	24V/200Ah
充电器 Charger	24V/36A

液压系统 Hydraulic System	
液压油容量 Hydraulic Oil Capacity	6L

整机重量 Machine Weight	2260kg
---------------------	--------

标准功能 Standard Features	
比例控制 Proportional control	可折叠护栏 Foldable guardrail
手动制动器释放 Manual brake release	室内室外适用 Indoor and outdoor rated
紧急停止装置 Emergency stop device	旋出元件托盘 Swing-out component tray
紧急下降 Emergency descent	坑洞防护装置 Pothole guard
自锁式入口闸门 Self-lock entry gate	动作报警 All motions alarm
全高驱动器 Full-height drive	倾斜保护系统 Tilt alarm with lift cut-out
过载感应系统 Overload sensing system	工作指示灯 Descent alarm with flashing beacon
智能诊断系统 Intelligent diagnostic system	实心无痕轮胎 Solid non-marking tires
免维护电池 Maintenance-free batteries	

选配 Optional	
交流电源平台 AC power to platform	远程通信 Telematics
防撞保护 Anti-collision protection	可生物降解液压油 Biodegradable hydraulic oil
锂电池 Lithium battery	过载报警 Overload alarm
GPS远程定位 GPS remote positioning	

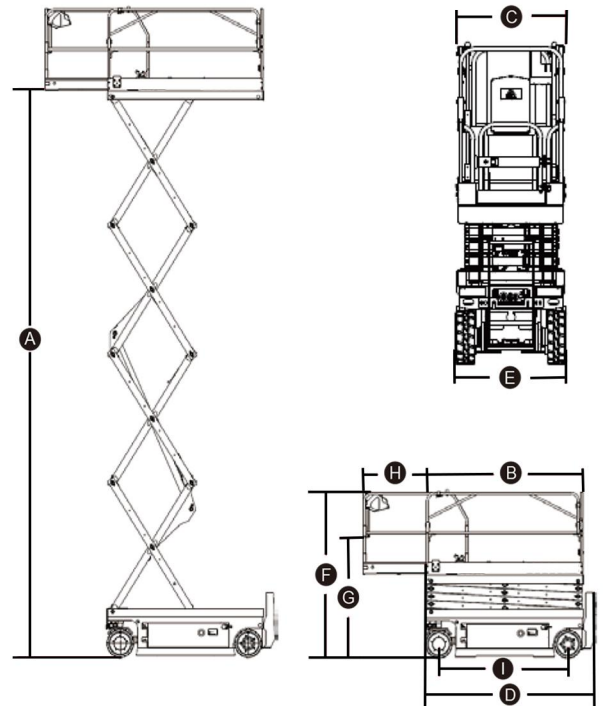

玖伍智能科技有限公司 Jovoo Industries Inc.

地址(Add): 山东省济南市济阳区济北开发区仁和街13号
No.13, Renhe Street, Jibei Development Zone, Jinan, China

电话(Phone): +86 198 5310 4505

邮箱(Email): contact@jovolift.com

网址(Website): www.jovolift.com



JOVVOO

Z08W

HYDRAULIC MOTOR DRIVE
SCISSOR LIFT

- Compact Structure
- Complete Safety Device
- Large Working Range
- Strong Battery Life



技术参数 (Technical Parameters)

型号 Models	Z08W
最大工作高度 Max. Working Height	9.8m
Ⓐ 最大平台高度 Platform Height-Raised	7.8m
Ⓑ 平台长度 Platform Length	2.27m
Ⓒ 平台宽度 Platform Width	1.12m
Ⓓ 整车长度 Overall Length	2.43m
Ⓔ 整车宽度 Overall Width	1.21m
Ⓕ 整机高度(围栏未折叠) Overall Height-Guardrails Up	2.35m
Ⓖ 整机高度(围栏折叠) Overall Height-Guardrails Down	1.9m
Ⓗ 平台延伸尺寸 Extension Deck	0.9m
Ⓘ 轴距 Wheelbase	1.87m
离地间隙 (收起/升起) Ground Clearance(Stowed/Raised)	0.11m/0.02m

性能 Productivity	
最大工作人数 Max. Platform Occupants	2
安全工作载荷 Platform Capacity	450kg
延伸平台安全工作载荷 Platform Capacity-Extension Deck	113kg
行驶高度 Drive Height	高空行驶
最大爬坡能力(收起) Gradeability-Stowed	25%
内侧/外侧转弯半径 Turning Radius-Inside/Outside	0/2.2m
提升/降低速度 Raise/Lower Speed	3-5m/min
驱动模式 Drive Mode	4x2
轮胎类型 Tire Type	实心无痕轮胎
轮胎尺寸 Tire Size	φ381×127mm

动力 Power	
电池 Battery	24V/200Ah
充电器 Charger	24V/36A

液压系统 Hydraulic System	
液压油容量 Hydraulic Oil Capacity	15L

重量 Weight	
整机重量 Machine Weight	2350kg

标准功能 Standard Features	
比例控制 Proportional control	可折叠护栏 Foldable guardrail
手动制动器释放 Manual brake release	室内室外适用 Indoor and outdoor rated
紧急停止装置 Emergency stop device	旋出元件托盘 Swing-out component tray
紧急下降 Emergency descent	坑洞防护装置 Pothole guard
自锁式入口闸门 Self-lock entry gate	动作报警 All motions alarm
全高驱动器 Full-height drive	倾斜保护系统 Tilt alarm with lift cut-out
过载感应系统 Overload sensing system	工作指示灯 Descent alarm with flashing beacon
智能诊断系统 Intelligent diagnostic system	实心无痕轮胎 Solid non-marking tires
免维护电池 Maintenance-free batteries	

选配 Optional	
交流电源平台 AC power to platform	远程通信 Telematics
防撞保护 Anti-collision protection	可生物降解液压油 Biodegradable hydraulic oil
锂电池 Lithium battery	过载报警 Overload alarm
GPS远程定位 GPS remote positioning	

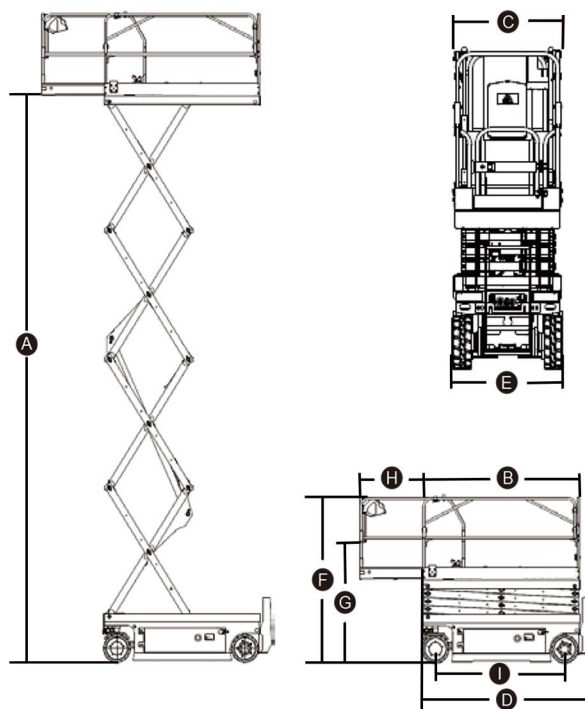

玖伍智能科技有限公司 Jovoo Industries Inc.

地址(Add): 山东省济南市济阳区济北开发区仁和街13号

No.13, Renhe Street, Jibei Development Zone, Jinan, China

电话(Phone): +86 198 5310 4505

邮箱(Email): contact@jovoolift.com

网址(Website): www.jovoolift.com



JOVVOO

Z10W

HYDRAULIC MOTOR DRIVE
SCISSOR LIFT

- Compact Structure
- Complete Safety Device
- Large Working Range
- Strong Battery Life



技术参数 (Technical Parameters)

型号 Models	Z10W
最大工作高度 Max. Working Height	11.8m
A 最大平台高度 Platform Height-Raised	9.8m
B 平台长度 Platform Length	2.27m
C 平台宽度 Platform Width	1.12m
D 整车长度 Overall Length	2.43m
E 整车宽度 Overall Width	1.21m
F 整机高度(围栏未折叠) Overall Height-Guardrails Up	2.47m
G 整机高度(围栏折叠) Overall Height-Guardrails Down	1.93m
H 平台延伸尺寸 Extension Deck	0.9m
I 轴距 Wheelbase	1.87m
离地间隙 (收起/升起) Ground Clearance(Stowed/Raised)	0.11m/0.02m

性能 Productivity	
最大工作人数 Max. Platform Occupants	2
安全工作载荷 Platform Capacity	450kg
延伸平台安全工作载荷 Platform Capacity-Extension Deck	113kg
行驶高度 Drive Height	高空行驶
最大爬坡能力(收起) Gradeability-Stowed	25%
内侧/外侧转弯半径 Turning Radius-Inside/Outside	0/2.2m
提升/降低速度 Raise/Lower Speed	3-5m/min
驱动模式 Drive Mode	4x2
轮胎类型 Tire Type	实心无痕轮胎
轮胎尺寸 Tire Size	φ381×127mm

动力 Power	
电池 Battery	24V/200Ah
充电器 Charger	24V/36A

液压系统 Hydraulic System	
液压油容量 Hydraulic Oil Capacity	20L

重量 Weight	
整机重量 Machine Weight	2550kg

标准功能 Standard Features	
比例控制 Proportional control	可折叠护栏 Foldable guardrail
手动制动器释放 Manual brake release	室内室外适用 Indoor and outdoor rated
紧急停止装置 Emergency stop device	旋出元件托盘 Swing-out component tray
紧急下降 Emergency descent	坑洞防护装置 Pothole guard
自锁式入口闸门 Self-lock entry gate	动作报警 All motions alarm
全高驱动器 Full-height drive	倾斜保护系统 Tilt alarm with lift cut-out
过载感应系统 Overload sensing system	工作指示灯 Descent alarm with flashing beacon
智能诊断系统 Intelligent diagnostic system	实心无痕轮胎 Solid non-marking tires
免维护电池 Maintenance-free batteries	

选配 Optional	
交流电源平台 AC power to platform	远程通信 Telematics
防撞保护 Anti-collision protection	可生物降解液压油 Biodegradable hydraulic oil
锂电池 Lithium battery	过载报警 Overload alarm
GPS远程定位 GPS remote positioning	

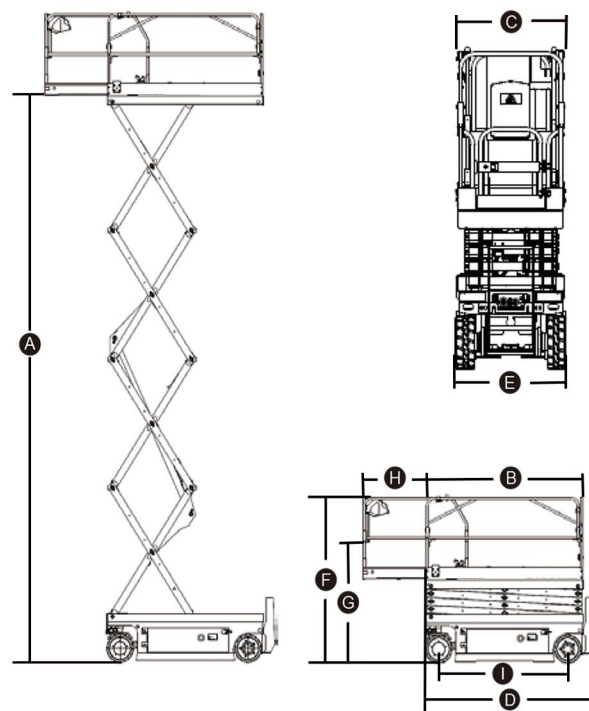

玖伍智能科技有限公司 Jovoo Industries Inc.

地址(Add): 山东省济南市济阳区济北开发区仁和街13号
No.13, Renhe Street, Jibei Development Zone, Jinan, China

电话(Phone): +86 198 5310 4505

邮箱(Email): contact@jovoolift.com

网址(Website): www.jovoolift.com



JOVVO

Z12W

HYDRAULIC MOTOR DRIVE
SCISSOR LIFT

- Compact Structure
- Complete Safety Device
- Large Working Range
- Strong Battery Life



技术参数 (Technical Parameters)

型号 Models	Z12W
最大工作高度 Max. Working Height	13.8m
Ⓐ 最大平台高度 Platform Height-Raised	11.8m
Ⓑ 平台长度 Platform Length	2.27m
Ⓒ 平台宽度 Platform Width	1.12m
Ⓓ 整车长度 Overall Length	2.43m
Ⓔ 整车宽度 Overall Width	1.21m
Ⓕ 整机高度(围栏未折叠) Overall Height-Guardrails Up	2.60m
Ⓖ 整机高度(围栏折叠) Overall Height-Guardrails Down	2.06m
Ⓗ 平台延伸尺寸 Extension Deck	0.9m
Ⓘ 轴距 Wheelbase	1.87m
离地间隙 (收起/升起) Ground Clearance(Stowed/Raised)	0.11m/0.02m

性能 Productivity	
最大工作人数 Max. Platform Occupants	2
安全工作载荷 Platform Capacity	320kg
延伸平台安全工作载荷 Platform Capacity-Extension Deck	113kg
行驶高度 Drive Height	高空行驶
最大爬坡能力(收起) Gradeability-Stowed	25%
内侧/外侧转弯半径 Turning Radius-Inside/Outside	0/2.2m
提升/降低速度 Raise/Lower Speed	3-5m/min
驱动模式 Drive Mode	4x2
轮胎类型 Tire Type	实心无痕轮胎
轮胎尺寸 Tire Size	φ381×127mm

动力 Power	
电池 Battery	24V/200Ah
充电器 Charger	24V/36A

液压系统 Hydraulic System	
液压油容量 Hydraulic Oil Capacity	25L

重量 Weight	
整机重量 Machine Weight	2900kg

标准功能 Standard Features	
比例控制 Proportional control	可折叠护栏 Foldable guardrail
手动制动器释放 Manual brake release	室内室外适用 Indoor and outdoor rated
紧急停止装置 Emergency stop device	旋出元件托盘 Swing-out component tray
紧急下降 Emergency descent	坑洞防护装置 Pothole guard
自锁式入口闸门 Self-lock entry gate	动作报警 All motions alarm
全高驱动器 Full-height drive	倾斜保护系统 Tilt alarm with lift cut-out
过载感应系统 Overload sensing system	工作指示灯 Descent alarm with flashing beacon
智能诊断系统 Intelligent diagnostic system	实心无痕轮胎 Solid non-marking tires
免维护电池 Maintenance-free batteries	

选配 Optional	
交流电源平台 AC power to platform	远程通信 Telematics
防撞保护 Anti-collision protection	可生物降解液压油 Biodegradable hydraulic oil
锂电池 Lithium battery	过载报警 Overload alarm
GPS远程定位 GPS remote positioning	

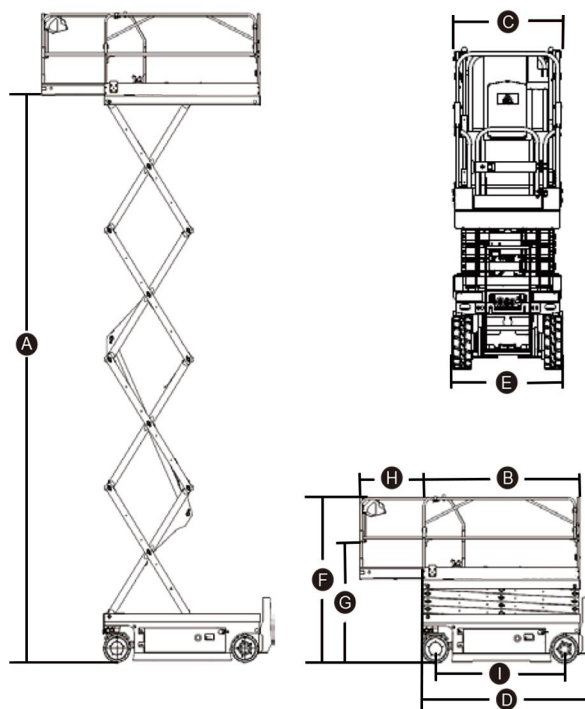

玖伍智能科技有限公司 Jovoo Industries Inc.

地址(Add): 山东省济南市济阳区济北开发区仁和街13号

No.13, Renhe Street, Jibei Development Zone, Jinan, China

电话(Phone): +86 198 5310 4505

邮箱(Email): contact@jovoolift.com

网址(Website): www.jovoolift.com



JOVVO

Z14W

HYDRAULIC MOTOR DRIVE
SCISSOR LIFT

- Compact Structure
- Complete Safety Device
- Large Working Range
- Strong Battery Life



技术参数 (Technical Parameters)

型号 Models	Z14W
最大工作高度 Max. Working Height	15.8m
Ⓐ 最大平台高度 Platform Height-Raised	13.8m
Ⓑ 平台长度 Platform Length	2.7m
Ⓒ 平台宽度 Platform Width	1.11m
Ⓓ 整车长度 Overall Length	2.85m
Ⓔ 整车宽度 Overall Width	1.31m
Ⓕ 整机高度(围栏未折叠) Overall Height-Guardrails Up	2.6m
Ⓖ 整机高度(围栏折叠) Overall Height-Guardrails Down	2.06m
Ⓗ 平台延伸尺寸 Extension Deck	0.9m
Ⓘ 轴距 Wheelbase	2.24m
离地间隙 (收起/升起) Ground Clearance(Stowed/Raised)	0.12m/0.02m

性能 Productivity	
最大工作人数 Max. Platform Occupants	2
安全工作载荷 Platform Capacity	230kg
延伸平台安全工作载荷 Platform Capacity-Extension Deck	113kg
行驶高度 Drive Height	高空行驶
最大爬坡能力(收起) Gradeability-Stowed	25%
内侧/外侧转弯半径 Turning Radius-Inside/Outside	0/2.5m
提升/降低速度 Raise/Lower Speed	3-5m/min
驱动模式 Drive Mode	4x2
轮胎类型 Tire Type	实心无痕轮胎
轮胎尺寸 Tire Size	φ381×127mm

动力 Power	
电池 Battery	24V/240Ah
充电器 Charger	24V/36A

液压系统 Hydraulic System	
液压油容量 Hydraulic Oil Capacity	30L

重量 Weight	
整机重量 Machine Weight	3570kg

标准功能 Standard Features	
比例控制 Proportional control	可折叠护栏 Foldable guardrail
手动制动器释放 Manual brake release	室内室外适用 Indoor and outdoor rated
紧急停止装置 Emergency stop device	旋出元件托盘 Swing-out component tray
紧急下降 Emergency descent	坑洞防护装置 Pothole guard
自锁式入口闸门 Self-lock entry gate	动作报警 All motions alarm
全高驱动器 Full-height drive	倾斜保护系统 Tilt alarm with lift cut-out
过载感应系统 Overload sensing system	工作指示灯 Descent alarm with flashing beacon
智能诊断系统 Intelligent diagnostic system	实心无痕轮胎 Solid non-marking tires
免维护电池 Maintenance-free batteries	

选配 Optional	
交流电源平台 AC power to platform	远程通信 Telematics
防撞保护 Anti-collision protection	可生物降解液压油 Biodegradable hydraulic oil
锂电池 Lithium battery	过载报警 Overload alarm
GPS远程定位 GPS remote positioning	

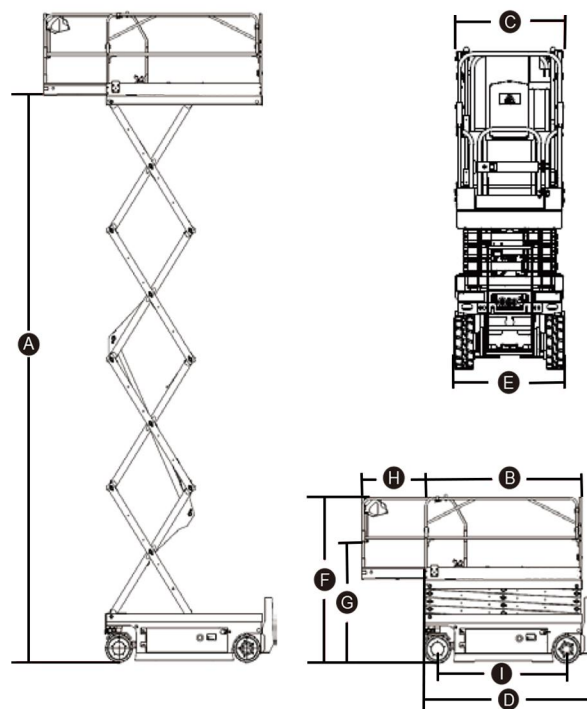

玖伍智能科技有限公司 Jovoo Industries Inc.

地址(Add): 山东省济南市济阳区济北开发区仁和街13号

No.13, Renhe Street, Jibei Development Zone, Jinan, China

电话(Phone): +86 198 5310 4505

邮箱(Email): contact@jovoolift.com

网址(Website): www.jovoolift.com

