



J A L E

COME FOR THE PARTS  
STAY FOR THE SERVICE



WEB: [HTTPS://WWW.JLEXCAVATOR-PARTS.COM/](https://www.jlexcavator-parts.com/)  
ADD: DONGCHANGFU DISTRICT, LIAOCHENG CITY, SHANDONG PROVINCE CHINA



QUALITY FROM PROFESSIONAL  
QUALITY CHANGES THE WORLD

WENDY  
MANAGER  
TEL: +86 17865576233  
E-MAIL: [wendyjiale@gmail.com](mailto:wendyjiale@gmail.com)  
WHATSAPP: +86 17865576233  
LINKEDIN: +86 17865576233



LOU  
VICE MANAGER  
TEL: +86 13355010111  
WHATSAPP: +86 13355010111  
LINKEDIN: +86 13355010111

SHANDONG JIALE IMPORT AND EXPORT CO., LTD





JALE introduces import equipment and adopts the foreign advanced production technology and raw materials, which not only increase the output, but also guarantee the product quality.

In the fast-changing market competition, the Company obtains the praises from the customers through constant innovation, good product quality and excellent product performance.



# COMPANY PROFILE

# PRODUCTION EQUIPMENT

Shandong Jiale Industry and Trade CO., LTD. (JALE) was founded in 2012. The company mainly specializes in production and the sales engineering machinery parts, and sales of engineering machinery and mining equipment. For 11 years, we have been pursuing excellence and striving to build an internationally competitive excavator parts company as our vision, to enhance value with quality and to be the most trusted excavator parts company; through the production of high-quality parts customers create value and then achieve our goals. Currently, the company boasts a professional technical R&D team and has entered in a long-term contract with many senior technical engineers and experts. JALE focuses on the production and development of excavator parts, besides the company has introduced the most advanced processing devices and testing methods to make production more professional, modern and large-scale.

JALE is an integrated production and sales enterprise integrating forging, processing and heat treatment. Our products have passed the ISO9001:2008 international quality management system certification. We develop and manufacture the market various types of imported and domestic excavator Bucket pins, high-strength Bucket bushings, Link bushings, I-link, H-link, Bucket teeth, Bolts&Nut, Track chain and other spare parts. The parts are applicable to KOMATSU, CAT, KOBELCO, HITACHI, DAEWOO and other well-known domestic and international brands of excavators. Now, we have developed our international market, currently our products are exported to Asia, Europe, North America and other regions.

JALE has always maintained innovation and leadership in the excavator parts market. We are committed to providing customers with better products and faster services. JALE measures our achievements through customer success and satisfaction.

JALE adheres to the business tenet of "High Quality, Lifetime Quality Assurance, Precise and Efficient", and abides by the "customer-centered" thinking, and fulfills the service tenet of satisfying customer needs as its own duty. Guarantee the high strength, high durability and high reliability of the products, and ensure the products with competitive price. We hope work with all new and old customers hand in hand, to create a brilliant tomorrow.

We sincerely welcome all to call and mails to communicate or for business negotiation.







Bucket Pin Series



Bucket Bushing Series

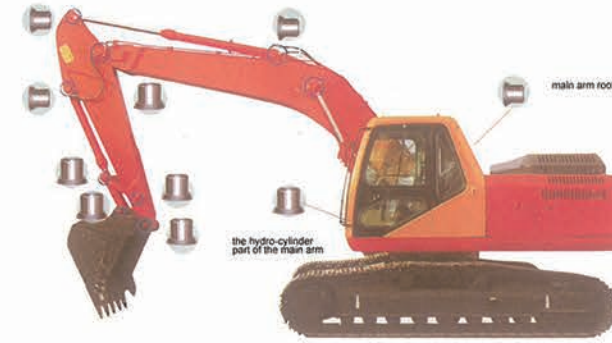

80 Bilateral Bucket Bushing



PC200 Special-purpose Bucket Bushing



PC300 Dotted Special-purpose Bucket Bushing



PC300 Special-purpose Bucket Bushing



PC400 Dotted Special-purpose Bucket Bushing



Dotted Phosphatized Bucket Bushing



Phosphatized Bilateral Bucket Bushing



Phosphatized Bucket Bushing



Bucket Bushing With Bilateral Oil Ducts



Bucket Link Series



SH65



EX200



SK140



DH380  
DH380 Original Machine



E320  
E320 Original Machine



PC220  
PC220 Original Machine



PC300  
PC300 Original Machine



ZAX350  
ZAX350 Original Machine



ZAX470  
ZAX470 Original Machine

Connecting Rod Series

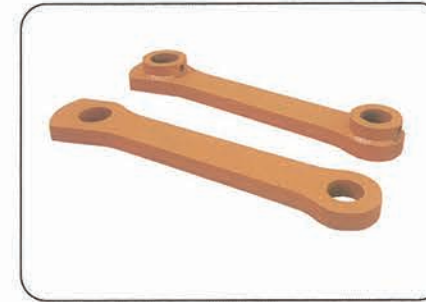

E320  
E320 Original Machine



EX200

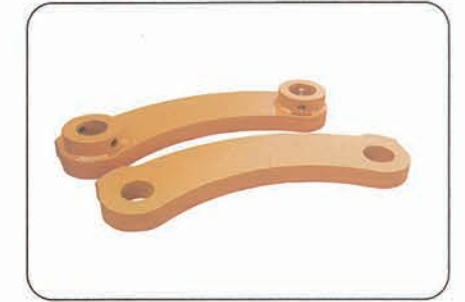

PC120  
PC120 Original Machine



50  
Kubota 50



SK460



EC460



DH220  
DH220 Original Machine



SY285  
SY285 Original Machine



PC360  
PC360 Original Machine





D41

SK200

PC60-5

EX100



Well lubricated oil recycle system

High Hardness ware-resisting alloy  
Chrom & Molybdenum floating seal  
and elastic rubber O ring

Deep hardened wear surface

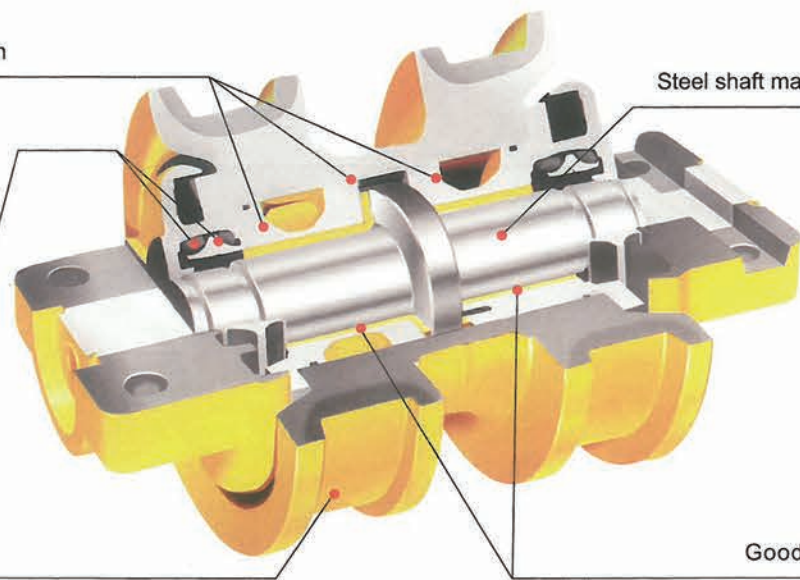

Steel shaft made by round steel or forging

Good quality Bronze bushings

Induction Harden illustration

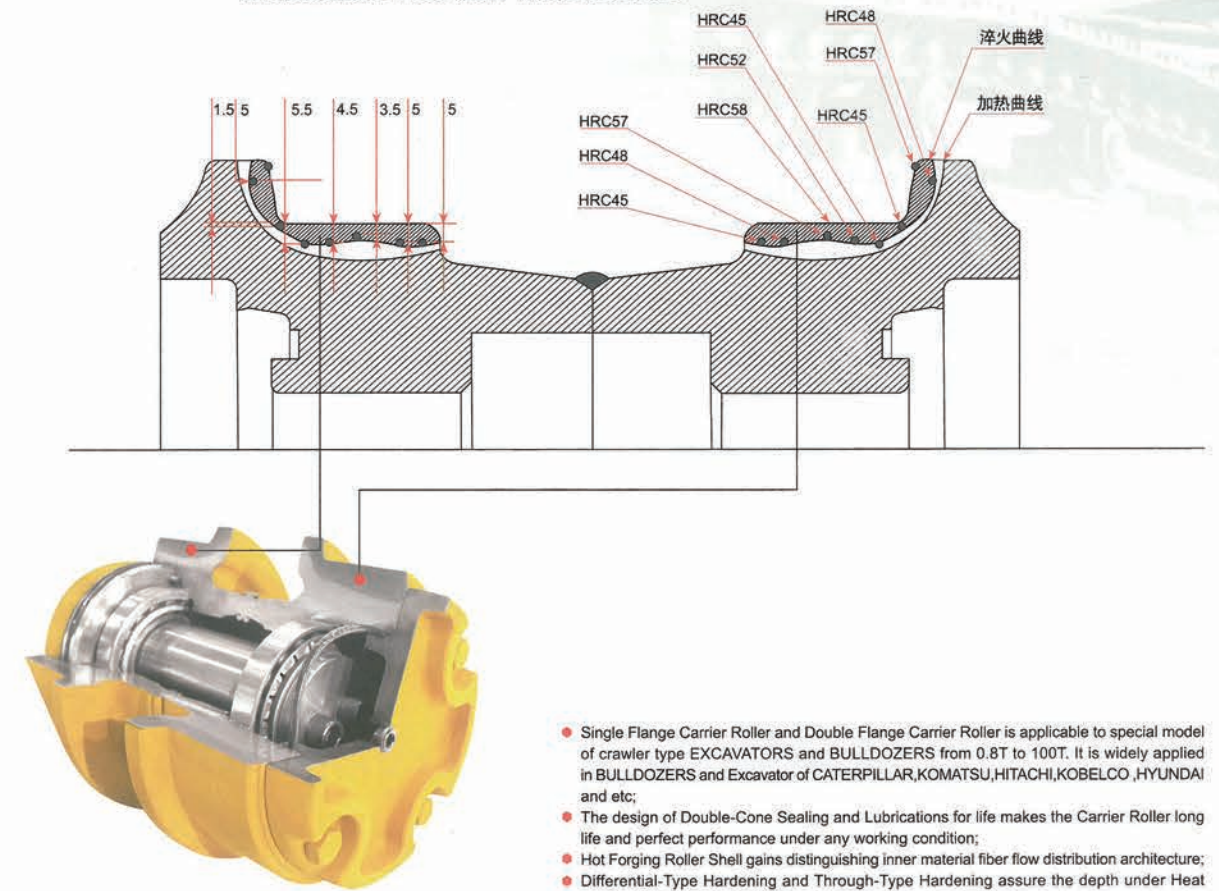

- Single Flange Carrier Roller and Double Flange Carrier Roller is applicable to special model of crawler type EXCAVATORS and BULLDOZERS from 0.8T to 100T. It is widely applied in BULLDOZERS and Excavator of CATERPILLAR, KOMATSU, HITACHI, KOBELCO, HYUNDAI and etc;
- The design of Double-Cone Sealing and Lubrications for life makes the Carrier Roller long life and perfect performance under any working condition;
- Hot Forging Roller Shell gains distinguishing inner material fiber flow distribution architecture;
- Differential-Type Hardening and Through-Type Hardening assure the depth under Heat Treating and the crack controlling.



EX200-5

D7G

SK200

PC200-5



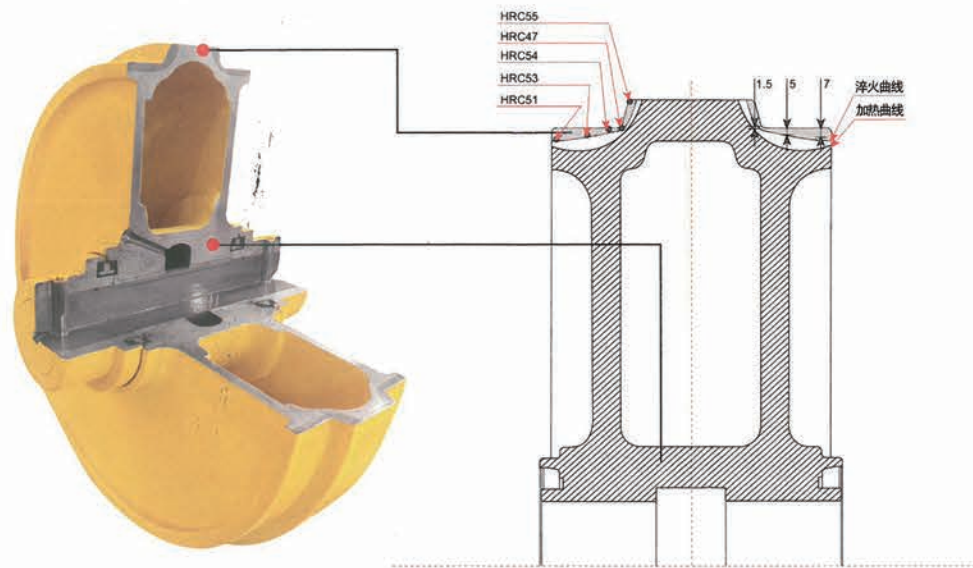
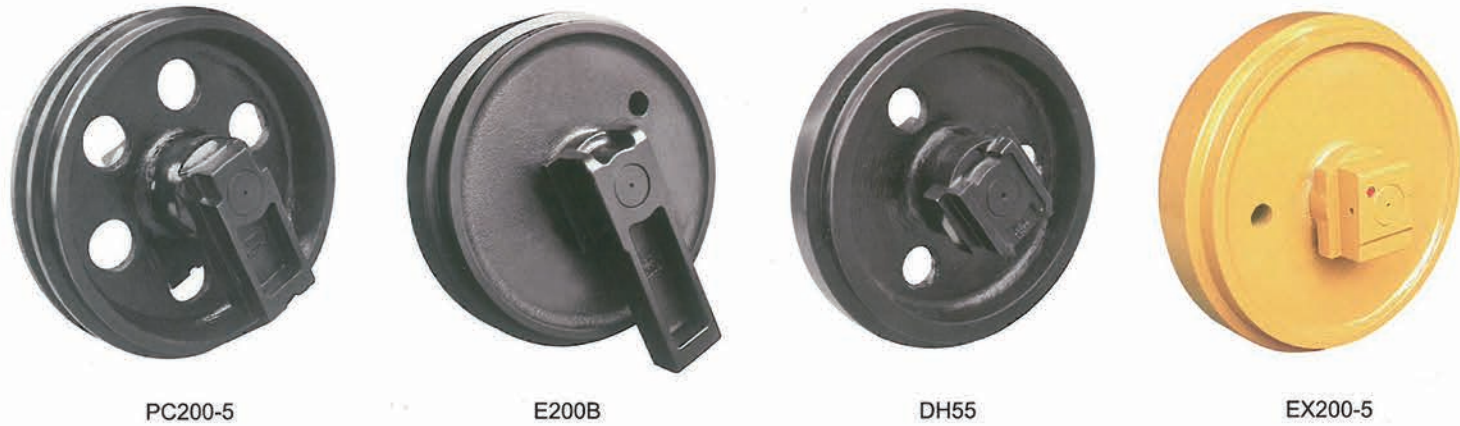

- Having wide choice range, the idler is applicable to special model of crawler type excavators and bulldozer from 0.8T to 100T. It is widely applied in bulldozers and excavators of Caterpillar, Komatsu, Hitachi, Kobelco and Hyundai etc.
- Have different manufacturing technology, like casting and welding.
- Use precision processing technology and special heat treatment technique to reach best wear-resistance and have maximum extent loading capacity as well as anti-cracking.

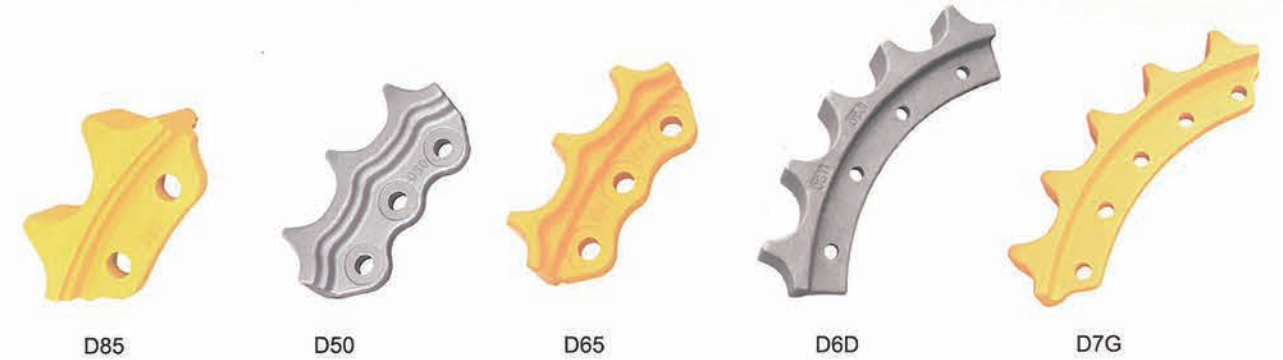
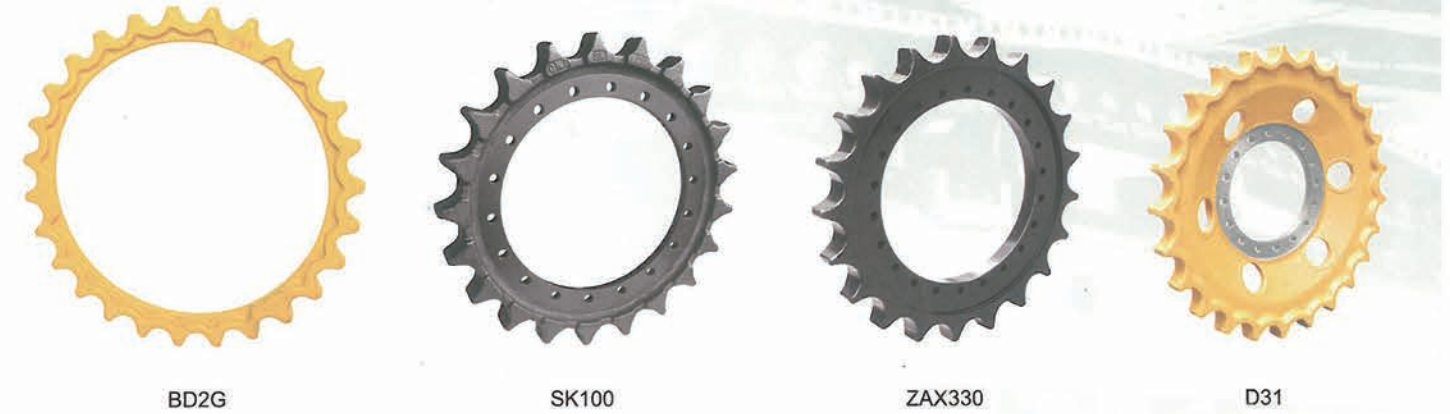

- Having wide choice range, the sprocket is applicable to special model of crawler type excavators and bulldozer from 0.8T to 100T. It is widely applied in bulldozers and excavators of Caterpillar, Komatsu, Hitachi, Kobelco and Hyundai etc.
- Adopts precision processing technology and special heat treatment technique, so reach the best wear-resistance and prolong life time to maximum extent.

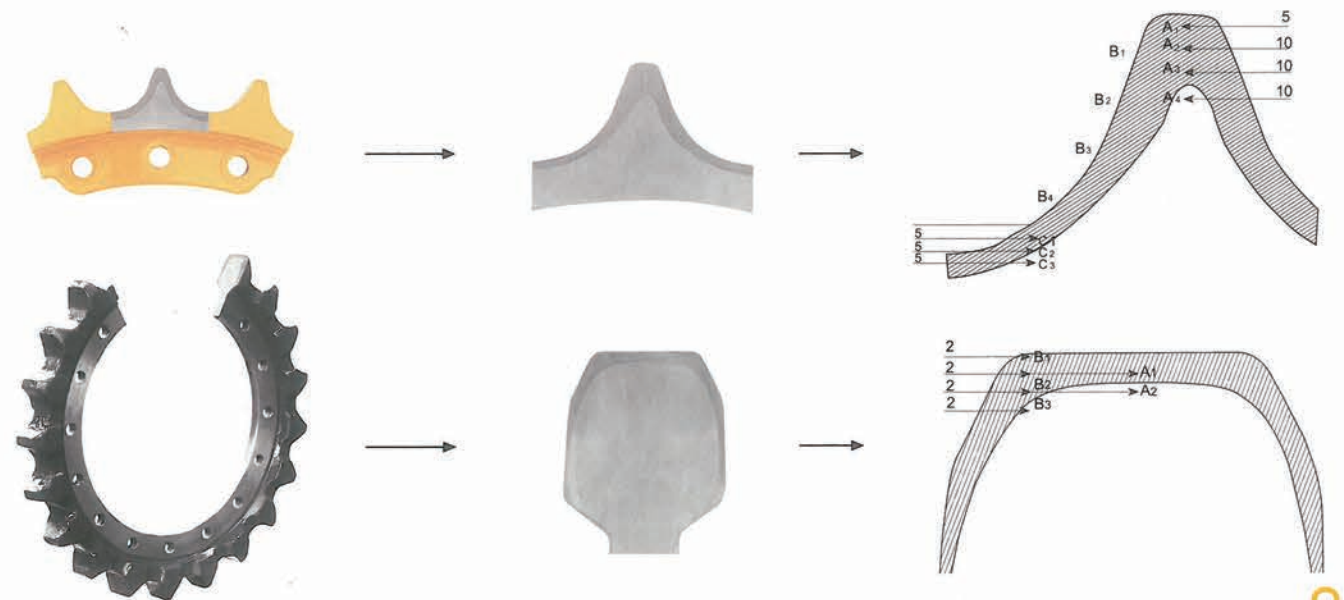





### Track Link

The combined track chain is elaborately cast with high-precision technique. Each pitch has perfect engagement. It guarantees the fast walking speed and excellent rotating performance of the excavator with high-standard quality. Its characteristic of light weight, high strength, simple structure and reasonable price can create more value for customers.

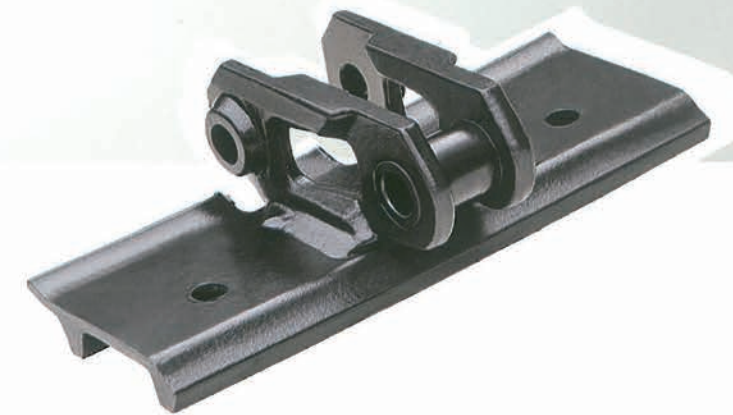
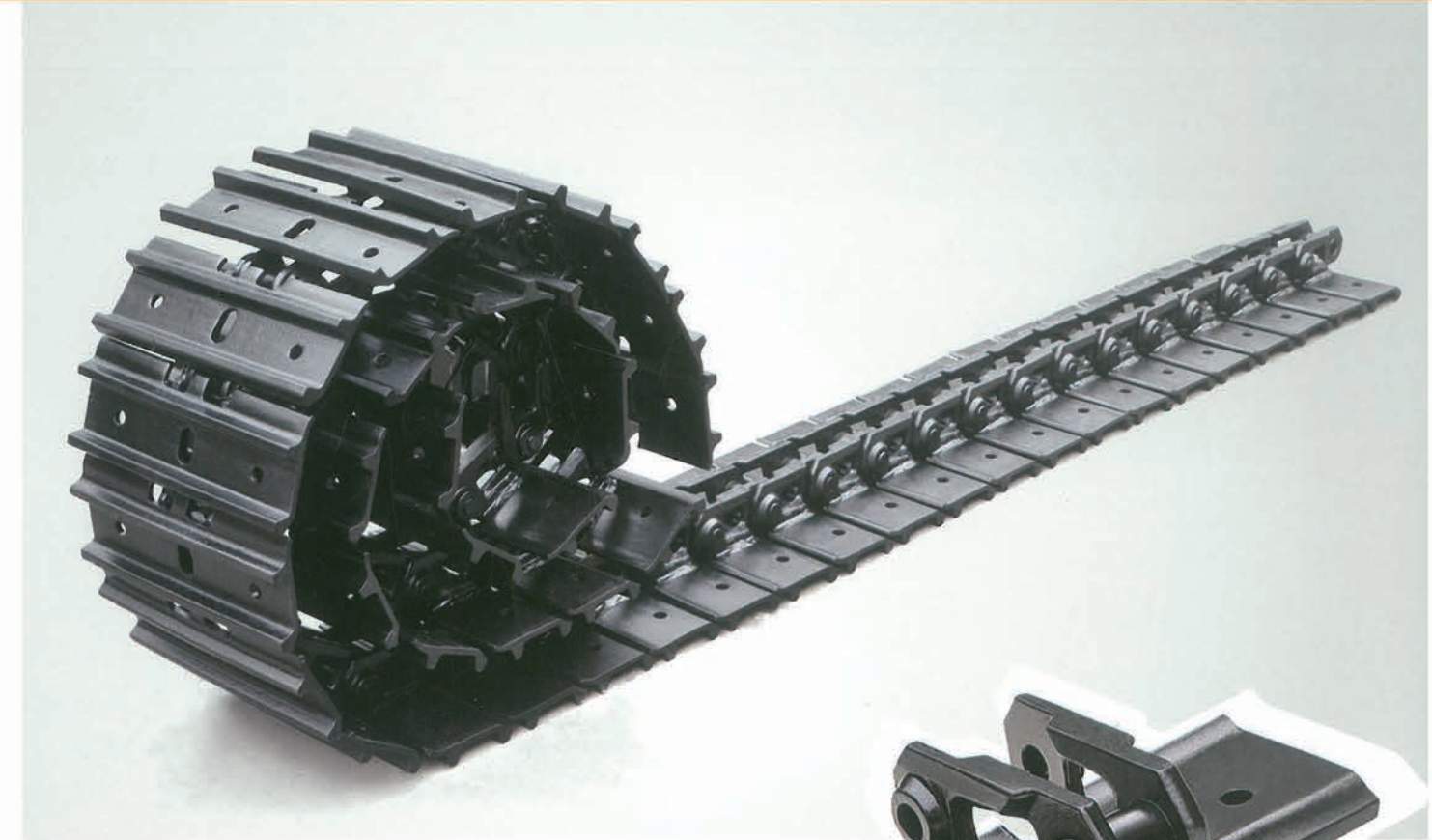
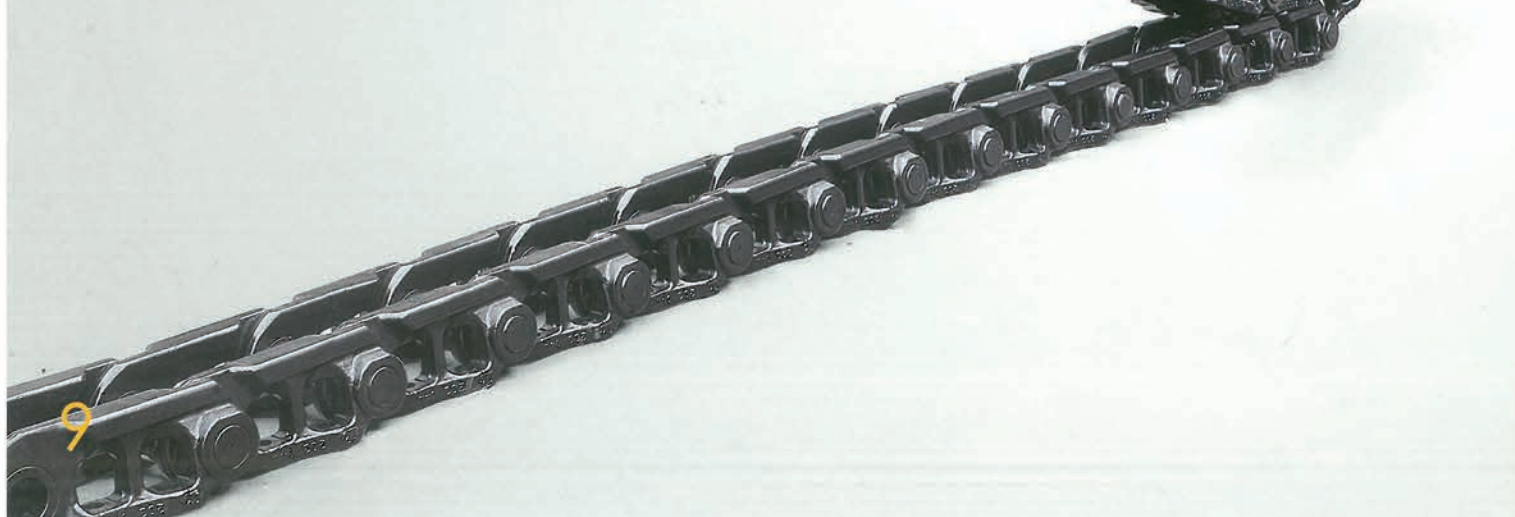

### Track Assembly

This is the high wear-resistant excavator track shoe after heat treatment. The choice of raw materials, high-tech heat treatment and the sophisticated skill improve the flexibility, high-strength wear resistance and service life of the track shoe in a comprehensive way, guarantees the super-strength smooth-going movement of the excavator and creates more value for customers.

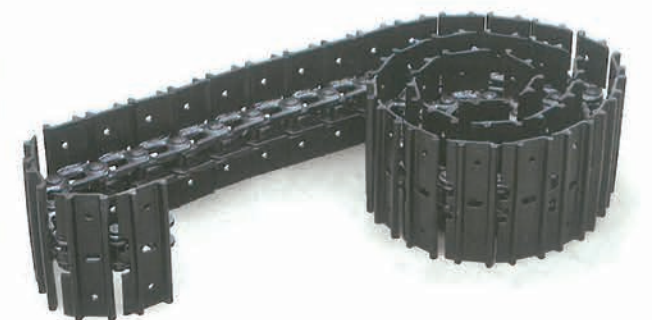





# Hot Bucket Series



EX330 1.4 CBM Rock Bucket



Cat320 1.0 CBM Heavy Duty Bucket



EX330 1.4 CBM Rock Bucket

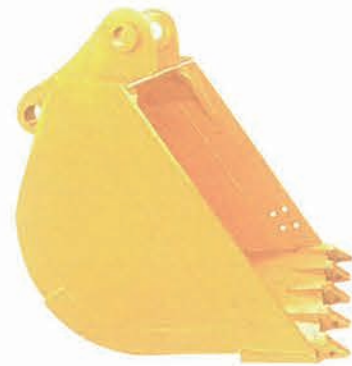

PC200 1.0 CBM Heavy Duty Bucket



Cat330D 1.6 CBM Rock Bucket



Bucket tooth-Forging

Bucket stand-Forging



Tooth pin



Spacer



Track guard



Endbit, cutting edge



Track Adjust



Cylinder



Link bushing



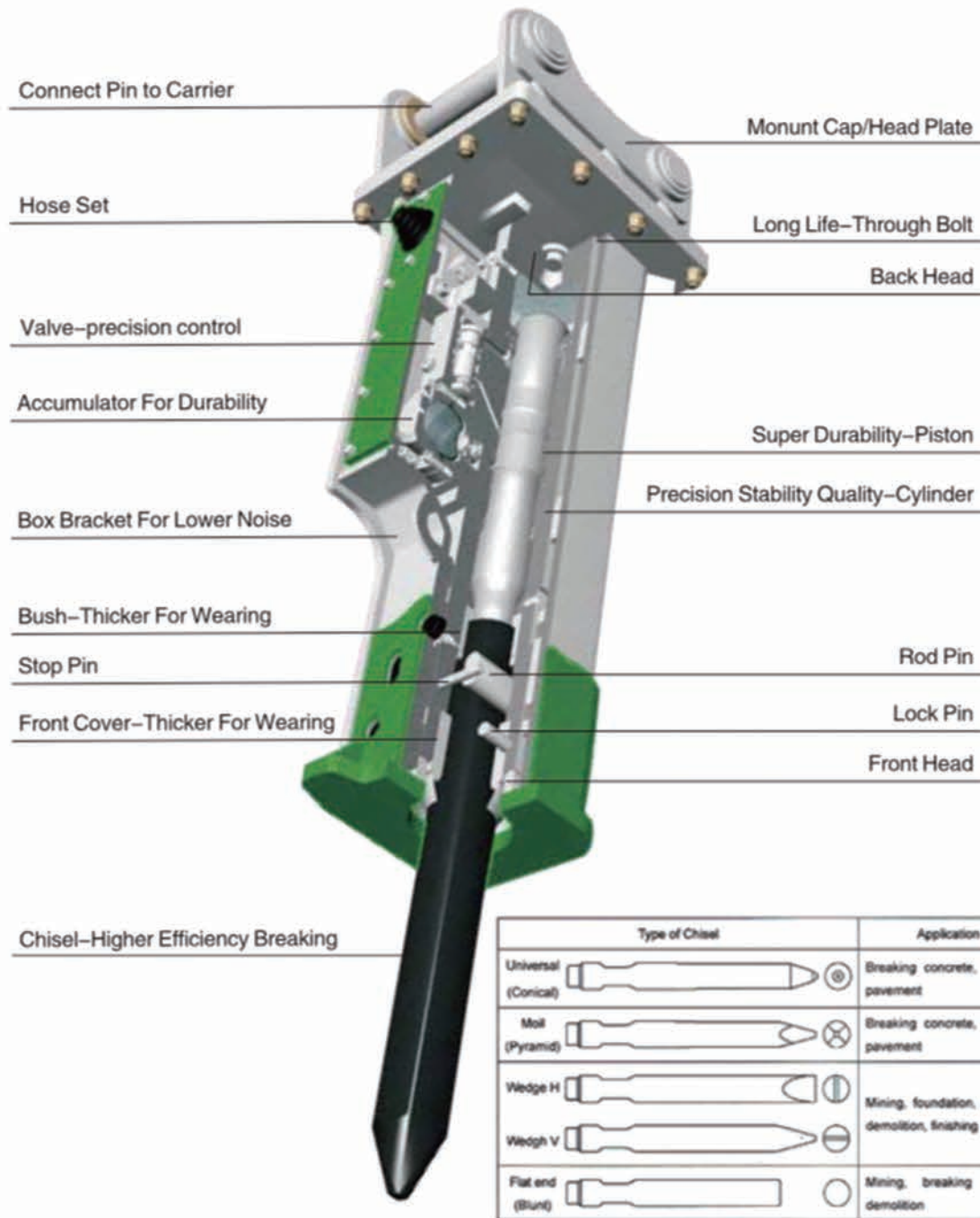

Drill Rod Series

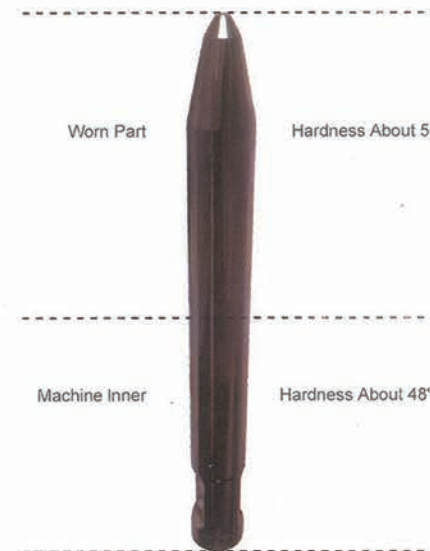

Adopt the sectional type quench to make drill shank wearale and not easily broken off.



Quick Coupler	Quick Coupler	SQ40P	SQ50P	SQ80P	SQ100H	SQ120H	Quick Coupler
	Type	Push type			Hitch type		
	L*W*H	543*306*225	765*388*346	925*493*414	970*545*515	1170*585*570	
	Installing Distance	230-280	380-420	455-485	490-545	530-610	
	Axis Disatnce	150	220	270	300	330	
	Required Oil Flow	10-20	10-20	10-20	10-20	10-20	
	Oil Pressure	40	40	40	40-380	40-380	
	Applicable Carrier Weight	3-5	7-15	18-26	27-30	30以上	

Special Alloy Steel	Special smithing technics	Special heat treatment method	Special performance and price ratio
---------------------	---------------------------	-------------------------------	-------------------------------------





### Chain Track Guard Series



DH55



DH300 Original Machine



E320 Original Machine



E330C Original Machine



EC210 Original Machine



HD450 Original Machine



R60 Original Machine



EX200



EX200 Imitation Original Machine



PC200 Original Machine



PC200 Imitation Original Machine



PC360 Original Machine



ZAX470 Siamesed Chain Track Guard



JALE introduces import equipment and adopts the foreign advanced production technology and raw materials, which not only increase the output, but also guarantee the product quality.



#### 欧美区

- 美国 U.S.A
- 西班牙 Spain
- 葡萄牙 Portugal
- 匈牙利 Hungary
- 爱尔兰 Ireland
- 俄罗斯 Russia
- 波兰 Poland
- 意大利 Italy
- 荷兰 Holand
- 加拿大 Canada
- 瑞典 Sweden
- 瑞士 Switzerland
- 希腊 Greek
- 英国 U.K
- 巴西 Brazil
- 乌拉圭 Uruguay

#### 亚澳区

- 澳大利亚 Australia
- 新西兰 New Zealand
- 日本 Japan
- 新加坡 Singapore
- 印度 India
- 孟加拉 Bangladesh
- 越南 Vietnam
- 印度尼西亚 Indonesia
- 菲律宾 Philippines
- 泰国 Thailand
- 韩国 Korea
- 马来西亚 Malaysia
- 中国香港 Hong Kong
- 蒙古 Mongolia
- 缅甸 myanmar
- 柬埔寨 Cambodia

#### 非洲区

- 埃及 Egypt
- 南非 South Africa

#### 中东区

- 以色列 Israel
- 土耳其 Turkey
- 沙特阿拉伯 Saudi Arabia
- 阿联酋 U.A.E
- 黎巴嫩 Lebanon
- 约旦 Jordan
- 科威特 Kuwait
- 伊朗 Iran