

**Automatic Grout Plant/Grout Station
Grout Equipment/Grout Mixer Pump**

GGP1200/1200/2x75/100PI-E Automatic Grout Station

- Mixer volume: 1200L
- Agitator volume: 1200L
- Piston pump 2 sets
- Max. Flow: 150L/min
- Max. Pressure: 100Bar
- Fully automatic mode and manual mode

GGP1000/4000/2x165/30PL-E Automatic Grout Station

- Mixer volume: 1000L
- Agitator volume: 4000L
- Plunger grout pump 2 sets
- Max. Flow: 2x(0-10m³/h)
- Max. Pressure: 30Bar
- Fully automatic mode and manual mode

GGP400/1000/95/165DPL-E/A Grout Mixer and Pump

- Mixer volume: 400L
- Agitator volume: 1000L
- Grout pump adjustable pressure: 0-165Bar
- Grout pump: 0-95L/min adjustable flow rate
- Fully automatic mode and manual mode
- Trailer type, easy to move

**Grout Plant/Grout Station/Grout
Equipment/Grout Mixer Pump**

GGP400/700/80/100DPI-D Grout Station

- Mixer volume: 400L
- Agitator volume: 1200L
- Pump flow and pressure: 40Bar@80L/min
- 100Bar@40L/min
- Yanmar diesel engine

GGP400/700/80DPL-D Diesel Engine Grout Inject Station

- Mixer capacity: 400L
- Agitator capacity: 700L
- Pump output/pressure: 80L/min@50Bar
- Double plungers, no pulse

GGP300/300/75PI-E Grout Plant

- Mixer capacity: 300L
- Mixer rated rev.: 1450rpm
- Agitator capacity: 300L
- Agitator rated rev.: 36rpm
- Max. Flow: 75L/min
- Max. Pressure: 100Bar

GGP300/300/300/70/80PI-E Mortar Grout Plant

- Mixer capacity: 300L
- Agitator 1 capacity: 300L
- Agitator 2 capacity: 300L
- Pump type: Mortar pump
- Max. Pump flow: 70L/min
- Max. Pressure: 80bar

Grout Pump

GGH95/165PL-E High Pressure Grout Pump

- Adjustable pressure: 0-165Bar
- Adjustable flow rate: 0-95L/min
- Power: 37kw, 380V, 50hz
- hydraulic type

GGP120/30PI-E Electric Grout Pump

- Hydraulic system working pressure: 10MPa
- Number of reciprocation: 42 times
- Piston pump cylinder diameter: 110mm
- Piston pump piston stroke: 160mm
- Piston pump displacement @pressure: 120L/min @ 3MPa

GGH75/100PI-E High Pressure Vertical Grout Pump

- Low pressure: flow: 0-75L/min, pressure: 0-50bar
- High pressure: flow: 0-40L/min, pressure: 0-100bar
- Power: 7.5kw
- Flow and pressure can be adjusted step-loss

GP Series High-pressure Grouting Pump with Frequency-conversion

- Max. Pump flow: 280L/min
- Max. Pressure: 450Bar
- Max. Power 250kw
- Mainly for jet grouting work
- Diesel type for option

High Shear Grout Mixer and Agitator

Grout mixer is one high shear high speed colloidal mixer, could finish mixing work in 2-3 mins. Agitator is low mixing speed to prevent the cement from setting and remove air bubbles, ensure whole grout work continuously. Have electric type, diesel type for option. Also have automatic mixing station to improve work efficiency!!



Refractory Gunite Machine

GZ-6DR/RD Diesel Engine Driven Refractory Gunite Machine

- Maximum output: 6m³/hr
- Hopper capacity: 80L
- Max. aggregate size: 10mm
- Feed bowl pocket number: 16
- Hose ID: 38mm
- Diesel engine power: 8.2kw

GZ-3ER/S Electrical Refractory Gunning Machine

- Rotor volume: 6.3L
- Rotor speed: 4-8r/min
- Max. output: 1.5-3m³/h
- Max. Horizontal conveying distance: 200m
- Max. Aggregate size: 10mm
- Conveying hose inner diameter: 38/32mm

GDPX200 Refractory Conveying Unit

- Output capacity: 4m³/h
- Useful vessel volume: 200L
- Total vessel volume: 250L
- Max. Grain size of mixture: 16mm
- Electric motor power: 11kw

Refractory Gunning Machine

- Max. Output: 5m³/h
- Conveying hose ID: 32/38mm
- Hopper volume: 45L
- Motor power: 4kw

Pre-dampening Nozzle

- Low rebound, low dust
- Reduce additive water amount
- Improve refractory compactness and strength

Refractory Mixer and Shotcrete Pump

Refractory Pan Mixer

- Mixing capacity: 100kgs, 250kgs, 500kgs, 800kgs, 1000kgs
- Rotating speed: 43rpm, 41rpm, 36rpm, 40rpm, 40rpm
- Motor power: 4kw, 7.5kw, 11kw, 30kw, 37kw
- Feeding height: 1150mm, 1150mm, 1400mm, 2500mm, 2500mm

GPS-7A Refractory Shotcrete Pump

- Output: 4m³/h
- Max. Pressure: 15Mpa
- Distribution valve type: S valve
- Power: 30kw

Tundish Spraying Machine

- Hopper capacity: 1.5m³
- Pump capacity: 40L/min
- Pump pressure: 20bar
- Mixer power: 5.5kw
- Pump power: 7.5kw

Pressure Vessel Gunning Machine

- Output capacity: 60-100kg/min
- Particle size: 0-5mm
- Outlet diameter: DN45
- Conveying distance: 50m (H), 35m (V)
- Load materials amount: 1500kg

Shotcrete Machine

GZ-10S Wet and Dry Concrete Spraying Machine

- Max. Output: 10m³/h
- Accept max. aggregate size: 20mm
- Air motor power: 8kw (Electric motor power: 7.5kw)
- Air pressure: 8Bar
- With automatic lubrication system
- With additive pump for wet shotcreting work

GZ-9E/S Wet & Dry Sprayed Concrete linings and Convey Pea-gravel Machine

- Output: 9.5m³/h
- Accept max. aggregate size: 20mm
- Electric motor power: 7.5kw
- Demand air consumption: 12-14m³/min
- Air pressure: 2-4Bar
- With automatic lubrication system

Other Shotcrete Machine for Option



Hydroseeder

GHS series hydroseeder is driven by diesel engine, tank capacity has 1000L, 1200L, 2000L, 3000L, 4500L, 6000L, 8000L, 10000L, 13000L and 15000L for option. They are with an exclusive pump to handle the thickest slurries. They with different configuration, support customize



Material Blower Machine and Conveying Machine

Material Blower is a versatile machine that efficiently processes a variety of landscaping materials including: bark mulch, wood chips, compost, soil amendments and other bulk materials.

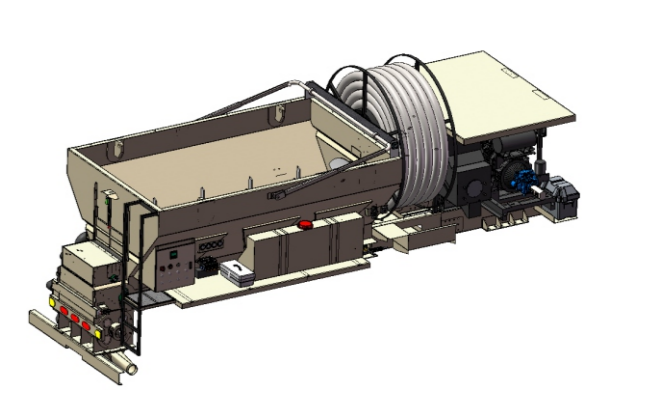

Hydraulic Jack

Lift Hydraulic jacks are used for bridge maintenance, bridge lift and bearing replacement, lift, lowering, weighing of heavy structures, center of gravity measurement, transfer of reinforced bearings/loads from temporary supports to fixed bearings, installation of heavy equipment, bridge sectional lifting and box lift. PC Strand multistrand hydraulic jack for tension PC strand.



Peristaltic / Hose Pump

Gaode GH series hose pump/peristaltic pump with tens of models, working pressure from 0-30bar, output from 0.01-50m³/h, NR, NBR, EPDM squeeze hose are available options for customization. Usually hose pump have very wide fields of application, such as construction, pharmacy, textile mill, dye making, water treatment, papermaking, mining, ceramic, underground engineering etc.



Planetary Concrete Mixer

GCPM planetary mixer is mixing with no hidden corners in the mixing pan by installing mixing tools and scraper tools on a specially designed drive system. Planetary Mixer has different mixing capacity from 5 to 4000 liters. It can mix all kinds of high-quality and high-performance concrete, and which can reach homogenous mixing at shortest time. It can also be widely used for glass, ceramics, refractories, fertilizer and concrete, etc.



Filter Press

The filter press is a solid-liquid separation equipment, uses the pressure difference between the two sides of the filter cloth to force most of the water in the material to pass through the filter cloth and flow out of the body, while the material is blocked in the filter chamber to form a filter cake to achieve the purpose of filtration. Due to the large pressure difference on both sides of the filter cloth during the filtration process, the filtration speed is increased and the moisture content of the filter cake is reduced.



Foam Concrete Equipment

Foam concrete machine also called Cellular Lightweight Concrete Machine, has been used in over 40 countries for building houses, apartments, schools, hospitals, industrial buildings, etc. We have developed full series of foam concrete machine with different models. The capacity from 5m³/h to 100m³/h. We also can supply CLC block cutting machine, foam agent and mould.



Jet Grouting Equipment

Jet Grouting Drilling Rig is suitable for built big diameter, deep soilcrete columns. Usually be applied to railway, highway, bridge, roadbed, dam foundation and other industrial and civil buildings, such as foundation reinforcement, water insulation and plugging engineering, soft foundation treatment and geological disaster control etc.



We also have other types for option, also could customize according to your demands, contact us now!!!

Gaode Equipment Co., Ltd.
No.1307, R&D Building #5, Block B, National University Science and Technology Park of Hainan Province, No.11 ChangChun Road, High-Tech District, ZhengZhou City, China
Tel: +86-371-55951210/55951660
Mobile/WhatsApp/Viber: +86-13939067523
Fax: +86-371-63526676
Email: info@gaodetec.com
Website: www.gaodetec.com www.gaodeequipment.com



GAODE EQUIPMENT
Offer you suitable machine or solution



Gaode Equipment Co., Ltd.
www.gaodetec.com