

技术参数 Technical Specification:

项目 Item	车型 Model	WT400	WT730	WT830	WT930	WT750D	WT870	WT1100	WT1200	WT1405	WT1605A
发动机型号 Engine Model	全柴 QC3B2	国产 China Engine	国产 China Engine	国产 China Engine	国产 China Engine	国产 China Engine	国产 China Engine	国产 China Engine	国产 China Engine	国产 China Engine	国产 China Engine
额定功率 Rated Power(KW)	26	39	45	45	45	45	65	65	85	85	85
标定转速 Rotating Speed(rpm)	2800	2650	2650	2650	2650	2300	2200	2200	2200	2200	2200
最大行驶速度 Max.Speed(km/h)	6.2	12	11.2	11.2	11.4/9.8	11.5	11.2/22.4	11.2/22.4	10.1/18.5	10.1/18.5	10.1/18.5
轮胎 Tire	23*8.5-12	10-16.5	10-16.5	12-16.5	250-15/23X10-12	10-16.5	12-16.5	12-16.5	12-16.5	12-16.5	12-16.5
额定载重 Operating Load(kg)	370	730	830	930	860	870	1100	1200	1400	1600	1600
倾翻载荷 Max.Loading(kg)	740	1460	1660	1860	1720	1740	2200	2400	2800	3200	3200
举升形式 Lifting Type	径向举升 Radial	径向举升 Radial	径向举升 Radial	径向举升 Radial	径向举升 Radial	径向举升 Radial	径向举升 Radial	径向举升 Radial	垂直举升 Vertical	垂直举升 Vertical	垂直举升 Vertical
工作三项和 Total Cycling Time (s)	9	10.2	10.2	10.2	8.6	11	9	9	9.5	9.5	9.5
铲斗容积 Bucket Capacity(m ³)	0.16	0.47	0.47	0.51	0.44/0.3	0.42	0.53	0.53	0.55	0.55	0.55
系统安全压 Pressure Of Working System (bar)	200	180	180	180	180	200	235	235	235	235	235
液压系统额定流量 Rated Flux(L/min)	43	80	80	80	80	80	76	76	75	75	75
大流量系统流量(选配) High Flow Flux(L/min)	无/without	无/without	无/without	无/without	无/without	无/without	140	140	150	150	150
燃油箱容量 Fuel Tank Capacity(L)	65	81	81	81	75	85	106	106	86	86	86
带标准铲斗自重 Self-weight With Bucket (kg)	1410	2850	2980	3230	3230	3050	3810	3970	4080	4260	4260

操作方式
 手动操作方式: 左手柄控制左边轮胎行走和动臂升降功能, 右手柄控制右边轮胎行走和铲斗的动作, 脚踏控制附具的装置工作。
 液控操作方式: 左手柄控制行走, 右手柄控制动臂、铲斗的动作, 开关控制附具的动作功能。
Operation Type
 Manual (Servo) control operation mode. The left handle controls the walking of left tire and lifting function of working arms, and the right handle controls the walking of right tire and movement of bucket, and the pedal controls the working of attachment.
 Hydraulic Joystick control operation mode. The left handle controls the walking, the right handle controls the movement of working arms and bucket, and the switch controls the working attachments.

主要参数 Main Specification

主要技术参数 Major	型号 Model	WT400	WT730	WT830	WT930	WT750D	WT870	WT1100	WT1200	WT1405	WT1605A
A 最大操作高度 Overall Operating Height (mm)		2666	3897	3857	3577	3710	4143	4143	4347		
B 至铲斗销高度 Height To Bucket Hinge Pin (mm)		2000	2982	2982	2729	2885	3205	3205	3407		
C 至驾驶室顶高度 Height To Top Of Cab (mm)		1520	2090	2090	1552/1420	2010	2065	2065	2075		
D 至铲斗底部的最大高度 Height To Bottom Of Level Bucket (mm)		1868	2855	2855	2531	2726	3010	3010	3217		
E 不带铲斗总长 Overall Length Without Bucket (mm)		2015	2536	2536	2637	2850	2857	2857	3051		
F 带铲斗总长 Overall Length With Bucket (mm)		2500	3352	3302	3367	3370	3649	3649	3835		
G 卸载高度 Dumping Height (mm)		1468	2266	2298	2044	2190	2460	2460	2679		
H 卸载距离 Dumping Reach (mm)		701	662	601	449	430	590	590	868		
I 铲斗在地面的翻转角度 Rollback Of Bucket On Ground (°)		30	25	25	38	25	30	30	26		
J 离地间隙 Ground Clearance (mm)		177	210	200	144	204	195	195	220		
K 离去角 Angle Of Departure (°)		28	30	32	24	26	26	26	26		
L 不带附件时前转弯半径 Front Turning Radius without Bucket (mm)		860	1252	1290	1299	1188	1338	1338	1390		
M 前转弯半径 Front Turning Radius (mm)		1518	2052	2036	2059	1983	2174	2174	2246		
N 后转弯半径 Rear Turning Radius (mm)		1210	1516	1516	1580	1634	1746	1746	1898		
O 车宽(标准轮胎) Width (mm)		1166	1730	1818	1806	1705	1798	1798	1864		
P 带标准铲斗宽度 Bucket Width (mm)		1250	1800	1880	2000	1740	1910	1910	1980		

产品数据如有改动, 恕不另行通知。
 Notice: Materials and specification are subject to change without notice.

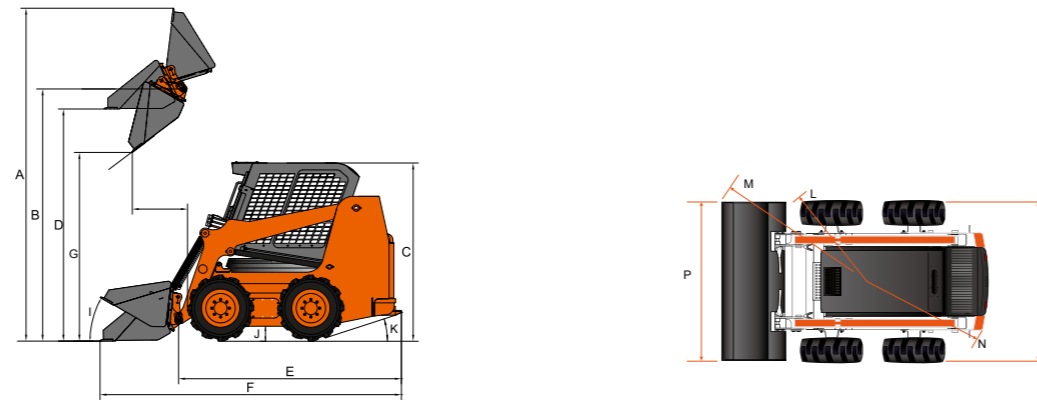

可选配置 Optional Configuration

WT730/WT830/WT930 选装配置/Optional Configuration	
发动机可选装/Optional Engine	新柴、全柴、科勒、日本五十铃、洋马、三菱/Xinchai, Quanchai, Kohler, Japan Isuzu, Yanmar, Mitsubishi
空滤形式可选/Optional Air Filter	标准空滤、旋风除尘过滤器、唐纳森三级空滤/Standard Air Filter, Cyclone Dust Filter, Donaldson 3-stage Air Filter
冷暖风形式可选/Optional Air-conditioner	单冷空调、冷暖空调、暖风/Cool Air-conditioner, Cool and Heat Air-conditioner, Heater
轮胎可选/Optional Tire	大花纹真空充气胎10-16.5、牧场耐磨小花纹充气胎10-16.5/Big Pattern Tubeless Tire 10-16.5, Wear-resistant Small Pattern Pneumatic Tire 10-16.5 for Pasture
液控系统可选/Optional Hydraulic System	苗莱机械伺服双联泵、苗莱液控双联泵、苗莱马达、波克兰马达/Inline Manual Servo Pump, Inline Hydraulic Control Pump, Inline Hydraulic Motor, France Poclain Motor
燃油系统可选/Optional Fuel System	寒冷地区柴油电控防冻系统/Antifreezing Fuel System for Cold Region

WT400配置/Configuration	
发动机可选装/Optional Engine	珀金斯403D-15T(29.4KW/2800r/min)、全柴3B2-35V31(26KW/2600r/min)/Perkins 403D-15T, Quanchai 3B2-35V31
轮胎/Tire	真空充气胎23*8.5-12/Tubeless Tire23*8.5-12
液控系统可选/Optional Hydraulic System	苗莱液控双联泵、苗莱马达、意大利进口双联泵、多路阀、液控手柄; 美国进口马达/Inline Hydraulic Control Pump, Inline Hydraulic Motor, Italy Double Pump, Multiway Valve, Hydraulic Joystick, American Motor
燃油系统可选/Optional Fuel System	寒冷地区柴油电控防冻系统/Antifreezing Fuel System for Cold Region

WT1100/WT1200选装配置/Optional Configuration	
发动机可选装/Optional Engine	全柴4C6-88C33(65KW/2200r/min)/Quanchai 4C6-88C33(65KW/2200r/min)
空滤器/Air Filter	标准空滤、唐纳森空滤/Standard Air Filter, Donaldson Air Filter
冷暖风形式可选/Optional Air-conditioner	单冷空调、冷暖空调、暖风/Cool Air-conditioner, Cool and Heat Air-conditioner, Heater
轮胎可选/Optional Tire	大花纹真空充气胎12-16.5、牧场耐磨小花纹充气胎12-16.5/Big Pattern Tubeless Tire 12-16.5, Wear-resistant Small Pattern Pneumatic Tire 12-16.5 for Pasture
液控系统可选/Optional Hydraulic System	苗莱机械伺服双联泵、苗莱液控双联泵、苗莱马达、波克兰马达、丹佛斯马达/Inline Manual Servo Pump, Inline Hydraulic Control Pump, Inline Hydraulic Motor, France Poclain Motor, Danfoss Motor
燃油系统可选/Optional Fuel System	寒冷地区柴油电控防冻系统/Antifreezing Fuel System for Cold Region

WT1405/WT1605A配置/Configuration	
发动机/Engine	全柴4J1-115C32(85KW/2200r/min)/Quanchai 4J1-115C32(85KW/2200r/min)
空滤器/Air Filter	珀金斯1104D-E44TA(87KW/2200r/min)/Perkins 1104D-E44TA(87KW/2200r/min)
冷暖风形式可选/Optional Air-conditioner	标准空滤、唐纳森空滤/Standard Air Filter, Donaldson Air Filter
轮胎可选/Optional Tire	大花纹真空充气胎12-16.5、牧场耐磨小花纹充气胎12-16.5/Big Pattern Tubeless Tire 12-16.5, Wear-resistant Small Pattern Pneumatic Tire 12-16.5 for Pasture
液控系统可选/Optional Hydraulic System	苗莱机械伺服双联泵、苗莱液控双联泵、苗莱马达、波克兰马达、丹佛斯马达/Inline Manual Servo Pump, Inline Hydraulic Control Pump, Inline Hydraulic Motor, France Poclain Motor, Danfoss Motor
燃油系统可选/Optional Fuel System	寒冷地区柴油电控防冻系统/Antifreezing Fuel System for Cold Region



实心胎250-15/300-15
Solid Tire 250-15/300-15



可拆卸刃板, 易更换
Removable blade plate



钢制-轮胎式履带
Steel - rubber-tired track



高档减震座椅
Damping seat

山东威肯科技有限公司

SHANDONG WECAN TECHNOLOGY CO.,LTD

地址:中国菏泽曹县迎宾大道66号 邮编(P.C.):274400

Address: No. 66 Yingbin Avenue, Caoxian County, Heze City, Shandong Province, China

内销电话(Domestic Phone): +86-530-3893606 19953018868

传真(Fax): +86-530-3893666

外销电话(Export Phone): +86-530-3893601 19953018868

传真(Fax): +86-530-3893671

售后服务(After-sales Service): +86-530-3893616 19953018825

E-Mail:wecan@wecanforklift.com wecan@wecanfactory.com

Http://www.wecanfactory.com Http://www.wecanforklift.com

本公司保留技术参数变更的权力, 并不另行通知客户。如需详细规格, 请电话。2024年6月



多功能滑移装载机系列

Multi-function Skid Steer Loader



滑移主机 Skid Steer Loader

WT400



标准配置液压先导操作, 国产发动机, 铲斗液压调平。
Standard with Hydraulic Joystick and hydraulic controlling system, China brand Engine, bucket hydraulic balance

WT750D

推砂机
WT750D Push Sand Machine



标准配置液压先导操作, 国产发动机, 冷暖空调, 铲斗液压调平(可选装液压输出管路, 四种整车高度可选: 1575mm、1550mm、1500mm、1420mm)。
Standard with hydraulic controlling system, China brand Engine, Cool & Heat air conditioner, bucket hydraulic balance (Optional height : 1575mm, 1550mm, 1500mm, 1420mm)

WT1100/WT1200



标准配置机械伺服操作(可选装液压先导操作), 国产发动机, 双速行驶, 大流量系统, 铲斗液压调平。
Standard with manual (Servo) control (Optional Hydraulic Joystick and hydraulic controlling system), China brand Engine, double-speed driving, high flow, bucket hydraulic balance

WT730/830/930



标准配置机械(伺服)操作(可选装液压先导操作), 国产发动机, 铲斗液压调平。
Standard with manual (Servo) control (Optional Hydraulic Joystick and hydraulic controlling system), China brand Engine, bucket hydraulic balance

WT870



采用国产发动机, 可选进口发动机, 进口双联泵和马达, 全封闭驾驶室带风扇和暖风, 液压伺服操作使工作更轻松。
Adopts China brand engine, and optional imported engine; Adopts imported main pump and hydraulic motor; Closed cabin with fan and heater; Hydraulic joystick control make work easy and comfortable.

WT1405/WT1605



标准配置液压先导操作, 国产发动机, 双速行驶, 大流量系统, 冷暖空调, 铲斗液压调平。
Standard with Hydraulic Joystick and hydraulic controlling system, China brand Engine, double-speed driving, high flow, Cool & Heat air conditioner, bucket hydraulic balance

公路养护 Road maintenance



封闭清扫器用于公路、市政、港口、广场、工厂区路面的清扫。该附件可以向前或向后清扫路面上的灰尘和废料。迅速清扫停车场、人行道、码头和仓库。还可以用来均匀撒播材料。规格型号为72英寸、84英寸。效率为1200米/小时。铲斗容量为0.47L。滑移装载机配带的封闭清扫器，清扫大型铣削后的路面，形成机械化的施工组合。

Sweeper is used for cleaning of road, municipal administration, port, plaza and factory area, and it could move forward or backward to clean the the dust and waste. Rapid digging for parking lots, sidewalks, docks and warehouses. It could also be used to spread material evenly. Model number 72inches, 84inches. The efficiency is 1200m/h, and the capacity is 0.47L. Sweeper of skid steer loader could sweep the surface of milling road, and it is part of mechanized construction.



该辅具主要用于市政、公路上井盖附近损坏的沥青路面的切除。打开井盖，首先将定位器固定于井框内，其次将铣刨机的定位轴置于定位器中间圆孔内，随后调节刀具到沥青路面的距离，然后开始切割直到切割到土层为止。最后提起定位轴，定位器和切割下来的路面部分可随之提出。

This attachment is mainly used for cutting the damaged asphalt road on the manhole cover in municipal road. Open the manhole cover, firstly fix the positioner in the well frame, and adjust the cutter to the asphalt road, then begin to cut until the soil layer, finally lift the positioning shaft, then the positioner and the cutting asphalt part will be also lifted.

园林设备 Garden equipment



利用该附件可以在几分钟内完成挖掘、装载并重新种植树木。该附件可以使威肯滑移装载机变成一台移栽机械。操作者无需离开滑移装载机，即可挖掘、运输和种植一棵树。可张开液压控制前铲，使操作者几乎能从任何角度接近树木。移/植树机能够切割树根，快速挤压根部土包。有圆锥铲和截头圆锥铲两种铲。是专为高效和经济的操作设计的。它不仅可用于挖掘树木，还可以在几分钟内将树木装载到卡车上，只需要一个人可以完成所有任务。

Using this attachment, you could finish the digging, loading and replant trees in minutes. This attachment could make WE CAN skid steer loader become a transplanting machine. The operator can dig, transport and grow a tree without leaving his machine. Opening the hydraulically controlled front shovel, the operator could reach the tree from any angle. Tree spade could cut the root and squeeze the roots of soil bag quickly. There are two types of shovels: a coned shovel and a truncated coned shovel. It is designed for efficient and economical operation. It could be used for digging trees and also loading the trees onto the trucks in minutes, and only one person is enough.



滑移装载机配置该附件，将你的威肯滑移装载机变成一台配备全系列挖掘附件的强力挖掘。可广泛应用于燃气、自来水、电力电信等行业的管线铺设，以及园林的绿化。

Skid steer loader could be equipped with this single-arm backhoe. This attachment could make your WE CAN skid steer loader a very powerful excavator and it could be used in pipe laying and landscaping project in many different industries.

冬季除雪 Snow removal in winter



滑移装载机配置该附件，推雪板的角度可以左右调整30°，可以轻松快速地清除人行道上的薄雪，带避让功能不会破坏路面。

Skid steer loader could be equipped with this snow blade. The angle of snow blade could be adjusted by 30degree left and right, and it could remove the thin snow in the cross walk, and it will not destroy the road surface.



滑移装载机配置该附件，斜角清扫器可以快速和有效的清除灰尘、结块干泥、薄雪和其他废料。非常适合清扫车道、人行道、停车场、码头和仓库，尤其在狭小空间使用有明显的优势。并且不会破坏路面的摊铺表层。3种型号供用户选择60英寸、72英寸和84英寸。

港口清仓船厂推砂WT750D Port clearance and pushing gravel in shipyard WT750D



滑移装载机配置该附件，抛雪机用液压驱动系统清除人行道、车道和停车场厚厚的积雪。可调节支撑脚的高度，可定位铲斗高度防止其碰到沙力和破坏地面摊铺表层。抛雪距离长达12米远。

牧场设备 Pasture equipment



功功能:滑移主机带附件WT-051575型耙器通过滑移液压力控制角度可以调节长度，使耙器达到工作状态。滑移匀速行走通过松料把将牛舍奶牛卧床上高低不平的垫料进行疏松和整平功能。效率高，节约人力。

Function: Skid steer loader could be equipped with this WK-051575 horizontal rotary pickfront and control the turning angle by hydraulic system to adjust the length, so that the horizontal rotary pickfront could be in working situation. Skid steer loader is in a constant speed to make the padding loose and smooth in the cow house by horizontal rotary pickfront, and it is very high effectively and save manpower.



功功能:滑移主机带附件WT-0411B型U型推粪器主要用于牛舍粪道2.0米以上粪道清理。U型推粪器上面钢板结构下端及左右两端有橡胶刃板保护,防止损坏粪道防漏槽,并且快速清理粪道效率高。

Function: Skid steer loader could be equipped with this U-type manure blade. It is mainly used for cleaning manure more than 2meters coprodaeum. The upper U-type manure blade is made of steel plate, and the bottom and two sides have rubber blade protection, and this way could avoid destroying the anti-skid slot of coprodaeum, and it could finish the cleaning in the coprodaeum in a high efficiency.