



 徐州博汇电控科技有限公司
XUZHOUBOHUI ELECTRIC CONTROL TECHNOLOGY CO., LTD

2021

新起点开创新未来

合作·共赢

成信合作/共创未来



电话：0516-87735988

地址：江苏省徐州市经济技术开发区庙兴路7号

网址：www.dk.bhcmg.com.cn



 徐州博汇电控科技有限公司
XUZHOUBOHUI ELECTRIC CONTROL TECHNOLOGY CO., LTD

2021

新起点开创新未来

合作·共赢

成信合作/共创未来

电话：0516-87735988

地址：江苏省徐州市经济技术开发区庙兴路7号

网址：www.dk.bhcmg.com.cn





诚信立足 创新致远



02

过程稳定

Process stability

03

质量可靠

Reliable quality

01

技术创新

technological innovation

04

追求卓越

Pursuit of excellence



COMPANY PROFILE 企业简介 >>>

徐州博汇电控科技有限公司位于徐州经济开发区大庙工业园区内，占地18000平方米，成立于2018年12月，公司总注册资本1000万元，现有员工120余人，年销售收入近亿元，是中国生产工程机械仪表电气的专业厂家，主要从事各类工程机械专用仪表、仪表台、仪表盘总成、总线线束、电气控制系统、工程机械电子监控系统、各种多功能操纵台的生产与销售，目前主要客户有山东临工、三一重工、临工重机、山推股份、中联重科、柳工、合力股份，戴纳派克、青岛雷沃等国内外知名企业集团。

Xuzhou Bohui Electric Control Technology Co., Ltd. is located in Damiao Industrial Park, Xuzhou Economic Development Zone, covering an area of 18000 square meters. It was established in December 2018. The company has a total registered capital of 10 million yuan, more than 120 employees and an annual sales revenue of nearly 100 million yuan. It is a professional manufacturer of construction machinery instrument and electricity in China, mainly engaged in the assembly of special instruments, instrument consoles and instrument panels for all kinds of construction machinery Production and sales of bus harness, electrical control system, electronic monitoring system of construction machinery and various multi-functional consoles. At present, the main customers include Shandong Lingong, Sany Heavy Industry, Jinan Heavy machinery, Shantui Co., Ltd., Zoomlion, Liugong, heli Co., Ltd., dynapak, Qingdao Lovol and other well-known enterprise groups at home and abroad.

LEARN WIDELY FROM OTHERS ' STRONG POINTS
GATHER TALENTS
PUNCTUAL SHIBO
YUANYUZEHUI

CONTENTS 目录



博采众长 汇聚英才
守约施博 渊淳泽汇

- 05 ● 企业简介
Company profile
- 07 ● 企业荣誉
Enterprise honor
- 09 ● 专业设备
Professional equipment
- 15 ● 仪表台
Instrument platform
- 19 ● 仪表产品
Instrument series
- 23 ● 扶手箱
Armrest box
- 26 ● 线束
Wire harness
- 29 ● 线缆固定夹
Cable fixing clip
- 31 ● 连接器固定夹
Connector retaining clip
- 33 ● 销售与服务
Sales and Service



BHCMEG

BHCMEG

BHCMEG

ENTERPRISE HONOR 企业荣誉



FOR THE COUNTRY
BASED IN SHANDONG
团结奋进 共创辉煌





诚信立足 创新致远



- ◆ 拥有多台现代化进口设备，主要有：美国TYCO自动下线压接机，韩国KM自动下线压端机，喷码机，数码绕线机，超声波焊接机，并线塑胶机，微电脑仪表检测台等。
- ◆ 公司全面实施ERP管理，建立从计划到开发、生产、质量管理、销售、财务、采购、库房乃至公共管理的一系列流程，能够迅速及时生产、配送产品；
- ◆ 公司所生产的产品集成化程度高，可以快速发运到客户的生产线进行装配。
- ◆ it has a number of modern imported equipment, mainly including Tyco automatic offline crimping machine in the United States, KM automatic offline crimping machine in Korea, inkjet printer and digital winding machine, Ultrasonic welding machine, parallel plastic machine, microcomputer instrument test bench, etc.
- ◆ the company fully implements ERP management and establishes a system from planning to development, production, quality management, sales, finance, procurement, warehouse and even public management Set up processes to produce and distribute products quickly and timely;
- ◆ the products produced by the company are highly integrated and can be quickly shipped to the customer's production line for assembly.



专业设备

Professional equipment

线束检测仪
Harness testing instrument



自动下线压端机
Pressure-side automatic offline machine



全自动下线机组
Fully automatic crimping machine



电源线裁线机组
Power cable cutting unit



超静音端子机
Super Mute Terminal Machines



六边伺服免换模压接机
Hexagonal servo crimping machine



伺服压接机 套管烘缩机
Servo crimping machine Casing shrinkage machine



高低温试验箱
High-low temperature tester



沙尘试验箱
Dust chamber



淋雨试验箱
Rain chamber



电子万能试验机
Electronic Universal Testing



超级恒温槽
Bath



盐雾试验箱
Salt spray chamber

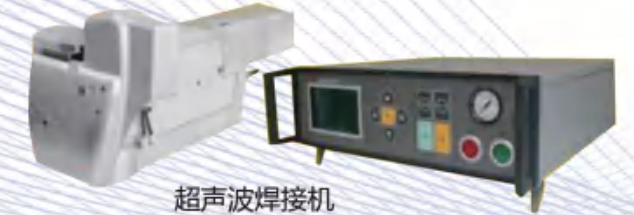

超声波焊接机
Ultrasonic welding machine



激光打标机
Laser Marking Machine



导线喷码机
Wire inkjet printer



标签机
Label printer



TN-Q压力校验台
Tn-q pressure check table

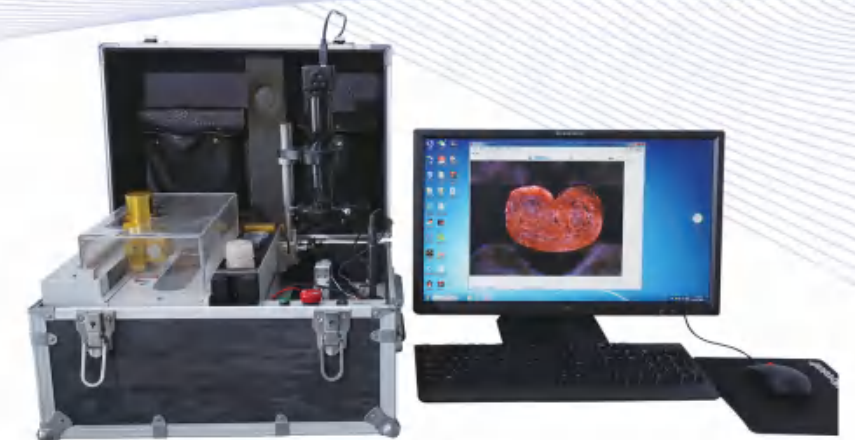

端子剖面分析仪
Terminal profile analyzer



诚信立足 创新致远



BHG101
适用：胶轮压路机
等路面工程机械

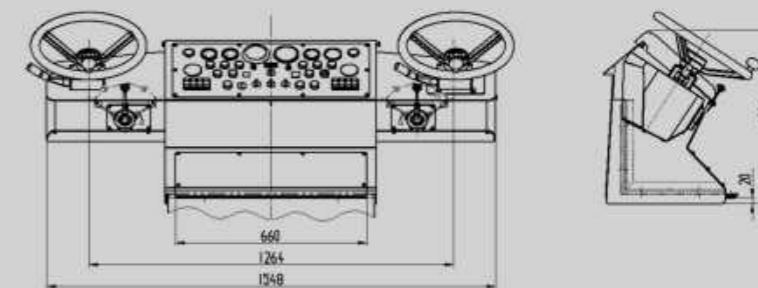

仪表台

Instrument platform

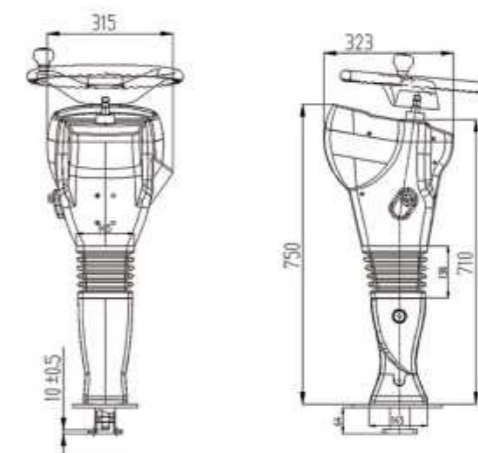

BHQ303/BHG303 适用：装载机等小型铲运工程机械

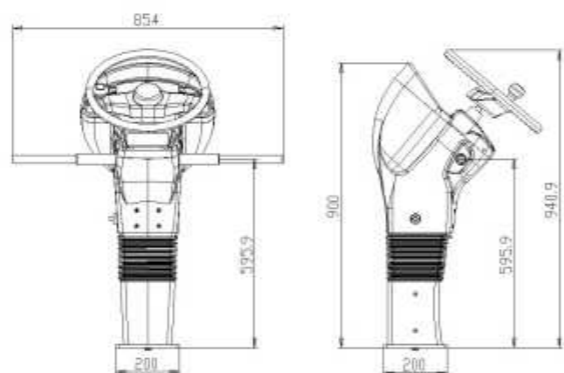

BHQ201

适用：平地机等路面机械工程车辆

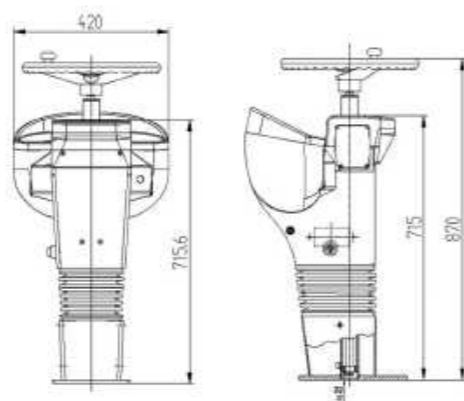

BHQ301/BHG301

适用：装载机、压路机等铲运压实工程机械

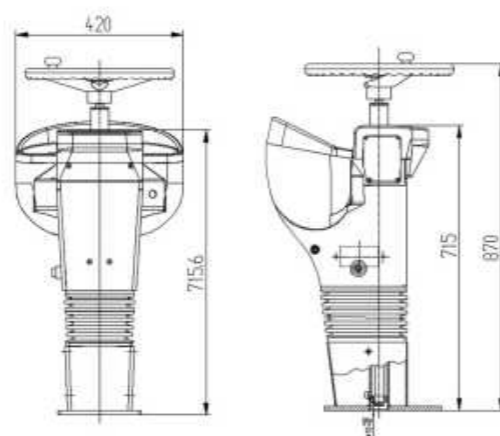

BHQ302/BHG302

适用：装载机、压路机等铲运压实工程机械

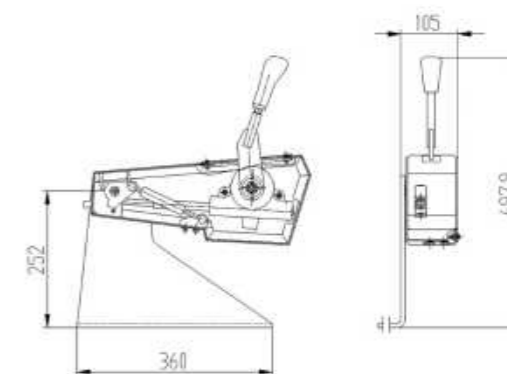

BHG101-1

适用：压路机等铲运压实工程机械

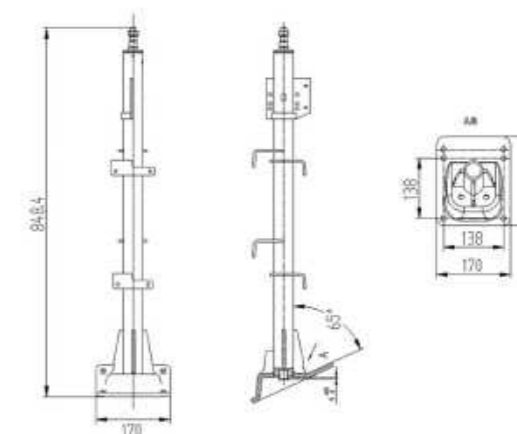

BHG401

适用：装载机等铲运压实工程机械

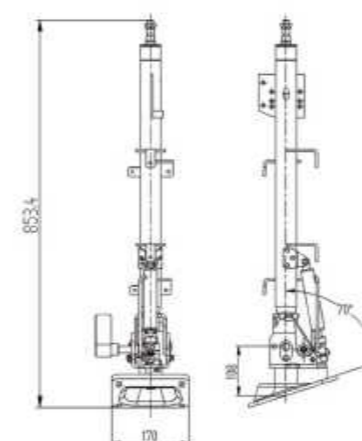

BHQ402

适用：装载机等铲运压实工程机械

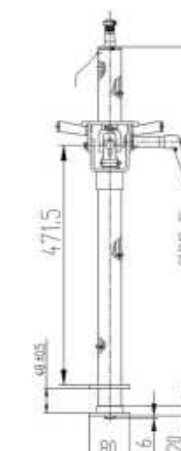

BHQ403

适用：装载机等铲运压实工程机械



诚信立足 创新致远



仪表产品

Instrument series



D0102000
水温表 (40-115)
SW201C总成
Water temperature gauge



D0104000
燃油表RY201总成
Fuel temperature gauge



D0105001
电压表DY201
voltmeter



D0107167
转速小时表GS901F
Tachometers



D0101051
车速里程表SL903A (0-30)
Speedometers with Odometers



D0103006
油温表YWB204A总成
Oil temperature gauge



D0104018
水量表RY201F总成
Water meter



D0111001
车速里程表SL85A11CAN
Speedometers with Odometers



D0119001
计时表JS55H61CAN
Hour meter



D0207004
转速传感器ZG901(M18*1.5*70)全丝
Speed sensor



D0112001
转速表ZS85A11CAN
Tachometer



D0114001
水温表SW55A11CAN
Water temperature gauge



D0204057
燃油传感器RG205-285 (直杆)
Fuel sensor

D0204012
燃油传感器RG205K-830 (直杆)
Fuel sensor



D0115001
油压表YY55A11CAN
Oil pressure gauge



D0116001
油温表YW55A11CAN
Oil temperature gauge



D0101097
组合表BH3GC-CL01-CAN
Instrument clusters



D6011038
油门电位器GE210H
Throttle sensor



D0109039
水量表Can52-01 (水位报警)
Water meter



诚信立足 创新致远



扶手箱

Armrest box



FSX-501

左箱外形尺寸: 554x120x332 (长x宽x高)
微挖用扶手箱, 整体可掀起约50°, 带手托、行程开关。
右箱外形尺寸: 476x130x310 (长x宽x高)
安装部件: 手油门、翘板开关、启动锁。



FSX-502

左箱外形尺寸: 516x202x328 (长x宽x高)
安装部件: 收音机、空调控制面板、杂物盒、锁止开关
右箱外形尺寸: 516x145x328 (长x宽x高)
安装部件: 启动锁、油门旋钮、备用电源、6个单翘板开关



FSX-503

左箱外形尺寸: 480x130x346 (长x宽x高)
安装部件: 钮子开关, 手托支架, 行走手柄
右箱外形尺寸: 480x130x318 (长x宽x高)
安装部件: 4个单翘板开关、点烟器



FSX-504

左箱外形尺寸: 445x160x326 (长x宽x高)
安装部件: 锁止开关、杂物盒
右箱外形尺寸: 478x180x326 (长x宽x高)
安装部件: 一键启动、推土铲、开关组件、杂物箱



FSX-505

左箱外形尺寸: 613x147x290 (长x宽x高)
安装部件: 锁止开关、备用电源、手托
右箱外形尺寸: 419x134x290 (长x宽x高)
安装部件: 启动锁、空调面板、推土铲、手托



FSX-506

左箱外形尺寸: 474x190x319 (长x宽x高)
安装部件: 锁止开关、手油门、收音机
右箱外形尺寸: 474x128x319 (长x宽x高)
安装部件: 启动锁、7个单翘板开关、推土铲



FSX-507
 左箱外形尺寸: 443x154x333 (长x宽x高)
 安装部件: 锁止开关、杂物盒
 右箱外形尺寸: 443x125x333 (长x宽x高)
 安装部件: 启动锁、六联翘板开关、推土铲



FSX-508
 左箱外形尺寸: 479x163x340 (长x宽x高)
 安装部件: 锁止开关、收音机、空调面板
 右箱外形尺寸: 479x140x340 (长x宽x高)
 安装部件: 启动锁、四联翘板开关、推土铲、油门旋钮



FSX-509
 左箱外形尺寸: 443x184x333 (长x宽x高) (不含手托)
 安装部件: 锁止开关、四联翘板开关、手托
 右箱外形尺寸: 443x125x333 (长x宽x高) (不含手托)
 安装部件: 四联翘板开关、手托



FSX-511
 左箱外形尺寸: 516x210x328 (长x宽x高)
 安装部件: 收音机、空调控制面板、杂物盒、锁止开关
 右箱外形尺寸: 516x156x328 (长x宽x高)
 安装部件: 启动锁、油门旋钮、备用电源、6个单翘板开关



FSX-510
 左箱外形尺寸: 345x200x310 (长x宽x高) (不含手托)
 安装部件: 锁止开关、手托
 右箱外形尺寸: 498x190x280 (长x宽x高) (不含手托)
 安装部件: 启动锁、手油门、推土铲、显示器、单翘板开关



FSX-512
 左箱外形尺寸: 580x170x330 (长x宽x高)
 安装部件: 锁止开关、翘板开关
 右箱外形尺寸: 620x202x330 (长x宽x高)
 安装部件: 集成开关面板、启动锁、备用电源、杂物盒等



线束

Wire harness

- ◆ 配套生产矿车、登高车、压路机、装载机、平地机、起重机、挖掘机、等各类工程机械线束及控制部件。
- ◆ Supporting the production of wire harness and control parts of various construction machinery such as mining car, climbing car, roller, loader, grader, crane, excavator and so on.



电机连接线束
Motor connection harness

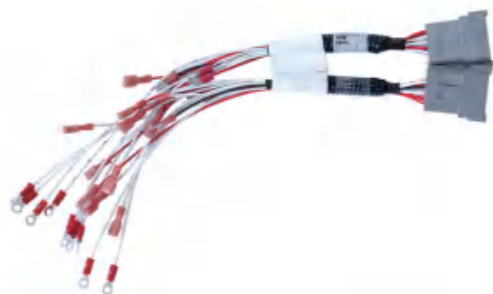

下控面板线束
Lower control panel harness



发动机线束
Engine harness



驱动电机线束
Drive motor harness



翘板开关线束
Rocker switch harness



电机控制线束
Motor control harness



电源线
Power cord



主线束
Main harness



控制板
Controller



诚信立足 创新致远



连接器固定夹

Connector retaining clip

- 用于固定德驰DT 系列, 德尔福15系列, AMP等连接器
- For fixed Deutsch DT, Delphi 15, AMP etc



名称	规格	材质
德驰卡板夹	003-08 -1DKDCBJ	不锈钢
德驰卡板夹	003-12 -1DKDCBJ	不锈钢
德驰卡板夹	003-08 -2DKDCBJ	Q235
德驰卡板夹	003-12 -2DKDCBJ	Q235



名称	规格	材质
AMP板夹	DK-AMP-01	不锈钢
德尔福卡板夹	DK-XJ-01	不锈钢

销售与服务

Sales and Service

适应市场，提升服务，博汇始终将创造客户价值，提升服务品质作为追求目标，全力打造售前、售中、售后的全方位服务体系。

To adapt to the market and improve service, Bohui always takes creating customer value and improving service quality as its pursuit goal, and makes every effort to build a comprehensive service system before, during and after sales.

战略合作伙伴

