

ENDURANCE
POWER
IMPROVEMENT
DEDICATION

IT'S SIMEX

GENERAL CATALOGUE

SIMEX
HEAVY MADE EASY

ENDURANCE
POWER
IMPROVEMENT
DEDICATION

IT'S SIMEX



Since 1991, the year it was founded, Simex has stood out for the innovative nature of its products. Production facilities have been expanded in order to accommodate a wider product range, with a view to increasing quality, production and logistics. Over the last 30 years, the company has become the technology partner of choice for thousands of earthmoving industry professionals worldwide.



Simex products are designed and engineered to be exceptionally durable and high-performing. A large amount of space is dedicated to testing equipment so as to ensure the highest quality standards where every area is reserved for a specific type of product. Today Simex boasts a state-of-the-art production department, with a monthly production capacity of up to 500 units during peak demand periods.



Constant investment in R&D is an essential lever of success for Simex and the pioneering quality of its production. The numerous patents Simex has filed over the years are a testament to its keen eye and can-do approach to a constantly evolving market.



Simex strongly believes in its human capital, the beating heart of the whole company, on which it has never stopped investing. An extensive sales network and prompt customer and after-sales service contribute to spreading brand awareness in over 80 countries, around the world. The proven reliability and engineering quality of Simex attachments stems from the commitment, passion and expertise of hundreds of people.

HYDRAULIC ATTACHMENTS FOR EARTHMOVING MACHINES

SIMEX IS THE TECHNOLOGY PARTNER OF CHOICE FOR COUNTLESS APPLICATIONS, EVEN THE MOST COMPLEX.

Simex produces hydraulic equipment for earthmoving machinery, boasting a wide and diverse range of products that covers various fields of

application: from the road sector to construction, from underground utilities to infrastructures, as well as demolition, quarrying and tunnelling. Simex equipment, featuring exceptional durability and engineering quality, ensure costs and execution times are optimized with consequent benefits for retailers and users.

THE NUMBERS

SIMEX
HEAVY MADE EASY



Scan the QR code using your smartphone



WATCH THE VIDEO

54,000 m²

TOTAL AREA

30+

PRODUCT RANGES

21,000 m²

INDOOR SPACE

120+

MODELS

80+

COUNTRIES COVERED

3

BRANCHES

65%

EXPORT

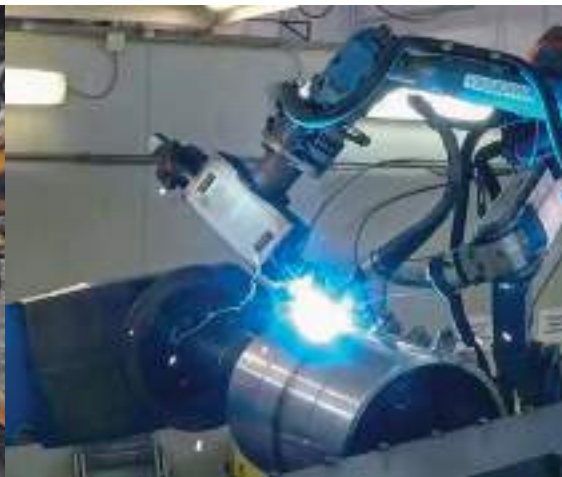

EQUIPMENT FOR



CBA

ASPHALT GRANULATOR BUCKETS

PAGE 12



CBE

CRUSHER BUCKETS

PAGE 14



CHD

CHAIN TRENCHERS

PAGE 16



CT

VIBRATING WHEEL COMPACTORS

PAGE 18



RWE

WHEEL SAWS FOR DEMOLITION

PAGE 30



TF

DOUBLE-DRUM CUTTER HEADS

PAGE 32



TFC

CUTTER HEADS
WITH CONTINUOUS CUTTING

PAGE 38



TFU

UNIVERSAL CUTTER HEADS

PAGE 42

EXCAVATOR



MP

CUTTER HEADS FOR PROFILING

PAGE 20



PLB/PHD

PLANERS

PAGE 22



PV

VIBRATING PLATE COMPACTORS

PAGE 26



RWE

WHEEL SAWS

PAGE 28



TFV

VERTICAL CUTTER HEADS

PAGE 44



VSE

SCREENING BUCKETS WITH ADJUSTABLE
OUTPUT SIZE

PAGE 46



VSU

UNIVERSAL SCREENING BUCKETS

PAGE 52



WG

WALL GRINDERS

PAGE 54

EQUIPMENT FOR FRONT LOADERS



ART

ASPHALT REPAIR TECHNOLOGY

PAGE 58



BC

BEACH CLEANERS

PAGE 62



CB

CRUSHER BUCKETS

PAGE 64



CHD

CHAIN TRENCHERS

PAGE 66



PL SG

ROAD PLANERS FOR MILLING
UNDER GUARDRAIL

PAGE 82



PLC

SELF-LEVELLING ROAD PLANERS
WITH CONVEYOR BELT

PAGE 84



RS

PLANERS FOR RUMBLE STRIPS

PAGE 86



RW/RWA

SELF-LEVELLING WHEEL SAWS

PAGE 88

AND COMPACT LOADERS



CT

VIBRATING WHEEL COMPACTORS

PAGE 68



PL

SELF-LEVELLING ROAD PLANERS

PAGE 70



PL

SELF-LEVELLING STABILIZERS

PAGE 78



PL RAIL

PLANERS FOR RAIL TRACKS

PAGE 80



ST

ASPHALT FLOAT

PAGE 92



T/TA

WHEEL SAWS

PAGE 94



VS

FRONTAL SCREENING BUCKETS

PAGE 98

INDEX BY APPLICATION

ROAD MAINTENANCE

RESTORATION

ART ASPHALT REPAIR TECHNOLOGY page 58

MILLING, SCARIFICATION

PL SELF-LEVELLING ROAD PLANERS page 70

PL SG ROAD PLANERS FOR MILLING UNDER GUARDRAIL page 82

PLB/PHD PLANERS page 22

PLC ROAD PLANERS WITH CONVEYOR BELT page 84

RS PLANERS FOR RUMBLE STRIPS page 86

STABILIZATION

PL SELF-LEVELLING STABILIZERS page 78

FILLING AND PAVING

ST ASPHALT FLOATS page 92

COMPACTION

CT VIBRATING WHEEL COMPACTORS FOR COMPACT LOADERS page 68

CT VIBRATING WHEEL COMPACTORS FOR EXCAVATORS page 18

PV VIBRATING PLATE COMPACTORS page 26

QUARRY, DEMOLITION & RECYCLING

DEMOLITION, MATERIAL SELECTION AND RECOVERY, QUARRYING, BACKFILLING, EXCAVATIONS AND PIPELINES

CB CRUSHER BUCKETS FOR COMPACT LOADERS page 64

CBA ASPHALT GRANULATOR BUCKETS page 12

CBE CRUSHER BUCKETS page 14

RWE WHEEL SAWS FOR DEMOLITION page 28

TF DOUBLE-DRUM CUTTER HEADS page 32

TFV VERTICAL CUTTER HEADS page 44

VS SCREENING BUCKETS FOR COMPACT LOADERS page 98

VSE SCREENING BUCKETS WITH ADJUSTABLE OUTPUT SIZE page 46

VSU UNIVERSAL SCREENING BUCKETS page 52

TRENCHING & UTILITIES

CUTTING, SET-SECTION TRENCHING, MINI- AND MICRO-TRENCHING

CHD	CHAIN TRENCHERS FOR COMPACT LOADERS	page 66
CHD	CHAIN TRENCHERS FOR EXCAVATORS	page 16
RW/RWA	SELF-LEVELLING WHEEL SAWS	page 88
RWE	WHEEL SAWS	page 28
T/TA	WHEEL SAWS	page 94
TF	DOUBLE-DRUM CUTTER HEADS	page 32
TFC	CUTTER HEADS WITH CONTINUOUS CUTTING	page 38

PROFILING & TUNNELLING

MP	CUTTER HEADS FOR PROFILING	page 20
PLB/PHD	PLANERS	page 22
TF	DOUBLE-DRUM CUTTER HEADS	page 32
TFC	CUTTER HEADS WITH CONTINUOUS CUTTING	page 38
WG	WALL GRINDERS	page 54

AGRICULTURE, FORESTRY, GREEN

BC	BEACH CLEANERS	page 62
CHD	CHAIN TRENCHERS FOR COMPACT LOADERS	page 66
CHD	CHAIN TRENCHERS FOR EXCAVATORS	page 16
TF	DOUBLE-DRUM CUTTER HEADS	page 32
TFC	CUTTER HEADS WITH CONTINUOUS CUTTING	page 38
VSE	SCREENING BUCKETS WITH ADJUSTABLE OUTPUT SIZE	page 46

PERFORMER

PERFORMER: WORK BETTER, WORK MORE, WORK FASTER

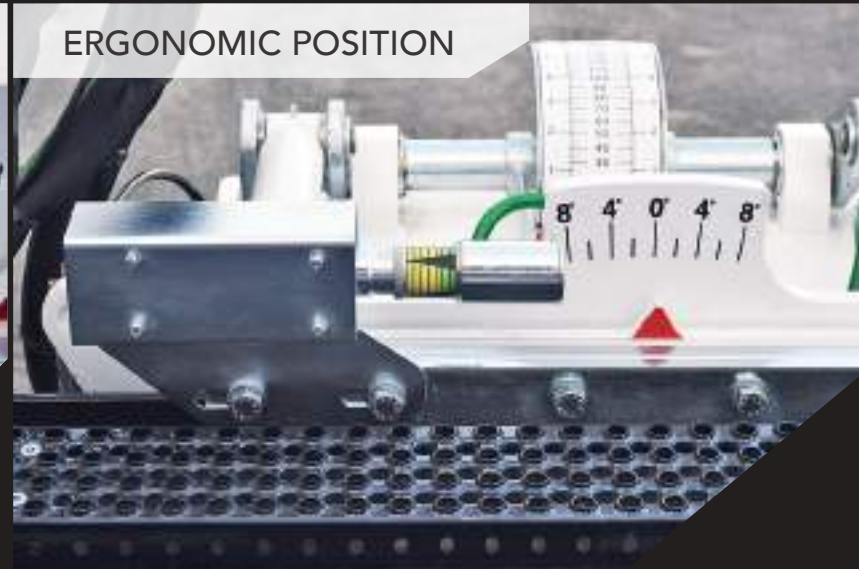

Scan the QR code using your smartphone to see the PERFORMER in action.



PERFORMER: PERFORMANCE OPTIMIZER

Allows the operator to optimize the equipment's performance according to the forward speed of the operating machine.

SELF-REGULATING

With the machine off, simply push the ring nut towards the internal support; once the motor has started, push forward until the drum adjustable output size) is locked. The Simex patent allows the device to self-calibrate exactly on the maximum pressure of the prime mover on which the equipment is installed.

EASY TO READ

Mounted in an ergonomic position, the operator can easily see it without being distracted from driving. Made with different colours and a graphic scale that make it easy to read. Push forward while staying on the green colour if you wish to optimize performance; instead, red means the drum will be locked, and therefore the machine will soon stop.

ROTATION DEVICES

RM 135° manual rotation

Manual rotation with hydraulic lock. For safely and quickly modifying the work angle without needing the excavator to be fitted with an auxiliary line.

Pressure is released via a hand-operated tap located on the side of the equipment, or from a button inside the cabin.

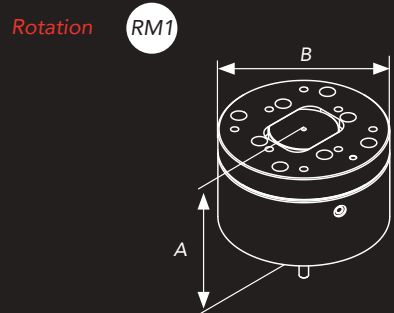

Technical data		Rotation RM1
Height	mm	180
Diameter	mm	290
Weight	kg	95

Equipment compatibility

RANGE	MODELS
CT Vibrating wheel compactors <i>(page 18)</i>	CT 2.8B, CT 3.8B
PLB/PHD Planers <i>(page 22)</i>	PLB 200, PLB 300, PHD 350, PLB 400, PLB 450
PV Vibrating plate compactors <i>(page 26)</i>	PV 300, PV 450, PV 600

RI 360° Hydraulic rotation

The 360° hydraulic rotation, operated from the cabin, makes it easy to position the equipment, so you can reach even the most difficult points, promoting productivity and operator comfort.

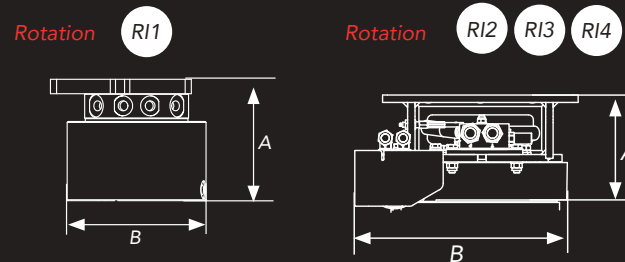

Technical data		Rotation RI1	Rotation RI2	Rotation RI3	Rotation RI4
Height A	mm	230	310	365	435
Width B	mm	230	500	540	665
Max. flow rate	l/min.	15	50	65	75
Max. pressure	bar	140	140	140	140
Weight	kg	70	120	195	230 (300*)
Motor type		piston	orbital	orbital	orbital

*for PHD weight 300 kg

Equipment compatibility

RANGE	MODELS			
	Rotation RI1	Rotation RI2	Rotation RI3	Rotation RI4
CT Vibrating wheel compactors <i>(page 18)</i>		CT 2.8B, CT 3.8B		
PLB/PHD Planers <i>(page 22)</i>	PLB 200, PLB 300	PHD 350, PLB 400	PLB 450, PHD 450	PLB 600
PV Vibrating plate compactors <i>(page 26)</i>	PV 300	PV 450, PV 600		PV 700, PV 850

RTF Rotation for TF* cutter heads

The 360° hydraulic rotation, operated from the cabin, makes it easy to position the equipment, so you can reach even the most difficult points, promoting productivity and operator comfort.

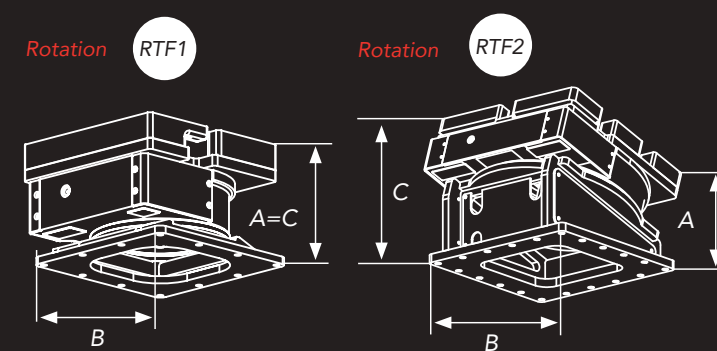

Technical data		TF 450	TF 650	TF 850 / TF 1100	TF 2100
		Rotation RTF1		Rotation RTF2	
Height A	mm	322	414	375	405
Width B	mm	475	475	610	700
Height C	mm	-	-	556	625
Max. flow rate	l/min.	60	70	75	80
Max. pressure	bar	175	175	175	175
Weight	kg	260	270	530	810
Speed of rotation	RPM	5 - 9	5 - 8	5 - 7	4 - 6
Motor type		orbital	orbital	orbital	orbital

*page 32

CBA

 12 - 40 TON
Excav.

ASPHALT GRANULATOR BUCKETS

CBA 20 | CBA 30 | CBA 40

The CBA asphalt granulator buckets are specially designed for the volumetric reduction of asphalt slabs or other aggregates directly on site. The cylindrical drum consists of interchangeable teeth, and is driven by direct-drive, high-displacement radial piston hydraulic motors.

The back-grille determines the size of the spoil piece and is available in different setups. The result is a reclaimed asphalt pavement (RAP) with a certifiable and measurable particle size.

WATCH THE VIDEO

Scan the QR code using your smartphone



The back-grille determines the size of the spoil piece and is available in different setups.



Füller grain size curve for 25 mm diameter grille:

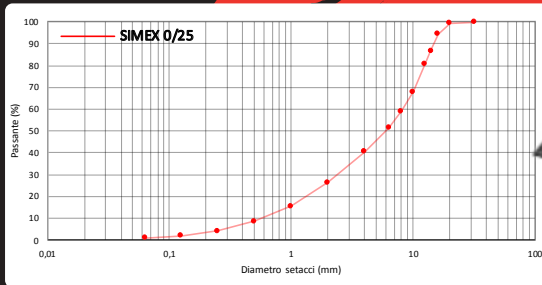

Cylindrical drum with asymmetric teeth distribution (Simex patented)

AUTOMATIC SYSTEM INVERTS the rotation of the drum in case of blocking, granting high productivity and avoiding downtimes.

TWO RADIAL PISTON HYDRAULIC MOTORS, high-displacement, in direct drive with the drum, generate high tooth force.

SIMEX
• patented •



RECOVERY OF ASPHALT MILLING

The CBA asphalt granulator bucket is specialized in the recovery of milled asphalt material, classified in national regulations as bituminous conglomerate granulate (otherwise known as RAP, Reclaimed Asphalt Pavement), and has the dual advantage of combining reduced construction site costs, supply of new raw materials, and possibility of reintroducing the milled material into the production cycle of new asphalt.

DOWNLOAD THE UPDATED TECHNICAL BROCHURE

Scan the QR code using your smartphone



TECHNICAL DATA		CBA 20	CBA 30	CBA 40
Recommended excavator weight (1) (2)	ton lbs	12 - 18 26400 - 40000	18 - 28 40000 - 62000	25 - 40 55000 - 88000
Total width B	mm inch	1485 58	1700 67	1960 77
Drum width A	mm inch	735 29	915 36	1050 41
Back-grille diameter	mm inch	25 - 30 - 35 - 40 1 - 1.2 - 1.4 - 1.6	25 - 30 - 35 - 40 1 - 1.2 - 1.4 - 1.6	25 - 30 - 35 - 40 1 - 1.2 - 1.4 - 1.6
Bucket capacity (SAE)	m ³ yd ³	0.60 0.78	0.8 1.05	1.0 1.30
Empty bucket weight (3)	kg lbs	1320 2900	2170 4775	2900 6400
Required oil flow	l/min gpm	100 - 190 26 - 50	150 - 250 40 - 66	200 - 350 53 - 93
Maximum oil pressure	BAR psi	350 5100	350 5100	350 5100

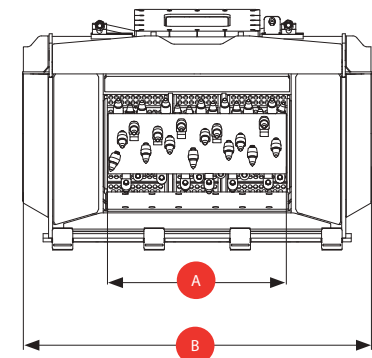
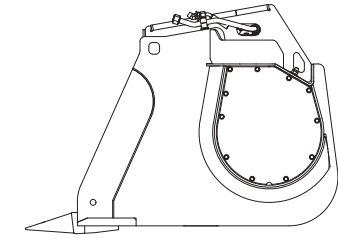

(1) The operating load permitted for the excavator, when added to the weight of the standard bucket, must match or exceed the weight of the crusher bucket at full load.

(2) The installer is responsible for ensuring that the equipment meets the excavator's specifications and weight requirement.

(3) Without mounting bracket.

Simex does not accept responsibility or liability for the information provided. Technical modifications may vary without prior notice.



CBE



8 - 40 TON

CRUSHER BUCKETS

CBE 10 | CBE 20 | CBE 30 | CBE 40

The CBE crusher buckets for excavators are designed for the volumetric reduction of aggregates directly on site and are ideal for crushing reinforced concrete and demolition materials. The rotor system they are equipped with and the high tooth force generated, allow optimal work with iron, rock, soil and deformable, damp or wet parts. The rotor with teeth is driven by direct-drive, high-displacement radial piston hydraulic motors. An automatic system inverts the rotation of the drum to avoid blockages and machine downtimes.

WATCH THE VIDEO

Scan the QR code using your smartphone



THE TOOLS ENGAGE THE SHAFT without any welding and are easy and quick to replace.

TWO RADIAL PISTON HYDRAULIC MOTORS, high-displacement, in direct drive with the drum, generate high tooth force. This ensures work is efficient and constant even with rebar inside the reinforced concrete.

UPON REQUEST, THEY MAY BE FITTED WITH TOOLS OF DIFFERENT SIZES to vary the size of the crushed material output.

BREAKABLE MATERIALS: masonry, reinforced concrete, bricks, natural aggregates, concrete, tiles, glass and asphalt slabs.

AUTOMATIC SYSTEM INVERTS the rotation of the drum in case of blocking, granting high productivity and avoiding downtimes.



SIMEX
• patented •





FEARLESS AGAINST IRON REBARS

In the treatment of aggregates, reinforced concrete is one of the most difficult materials to crush. The CBE buckets, thanks to the rotor system and the high tooth force, **are fearless against the iron rebars** inside demolition waste.



DOWNLOAD THE UPDATED TECHNICAL BROCHURE

Scan the QR code using your smartphone



TECHNICAL DATA		CBE 10	CBE 20	CBE 30	CBE 40
Recommended excavator weight (1) (2)	ton lbs	8 - 13 17500 - 28600	10 - 18 22000 - 40000	16 - 28 35000 - 61600	24 - 40 53000 - 88000
Mouth width	B mm inch	1030 41	1180 46	1410 55	1630 64
Total width	A mm inch	1220 48	1485 58	1700 67	1960 77
Rotor width	C mm inch	725 28	735 29	915 36	1050 41
Bucket capacity (SAE)	m ³ yd ³	0.40 0.52	0.60 0.78	0.80 1.04	1.00 1.30
Number of teeth	no.	5	5	6	7
Max. cutting force	kN lbf	80 18000	95 21500	125 28000	152 34000
Empty bucket weight (3)	kg lbs	880 1950	1320 2900	2170 4800	2900 6400
Required oil flow	l/min gpm	80 - 160 21 - 42	100 - 190 26 - 50	150 - 250 40 - 66	200 - 350 53 - 92
Maximum oil pressure	BAR psi	350 5100	350 5100	350 5100	350 5100

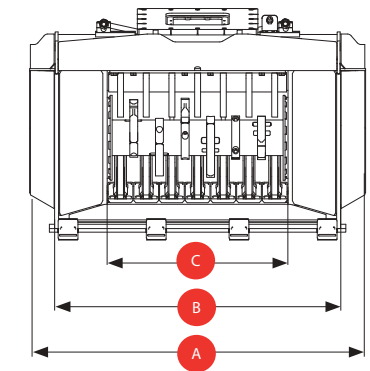
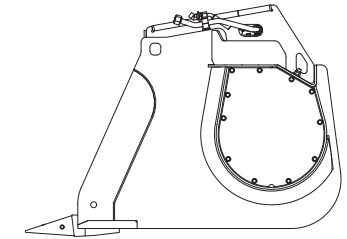

(1) The operating load permitted for the excavator, when added to the weight of the standard bucket, must match or exceed the weight of the crusher bucket at full load.

(2) The installer is responsible for ensuring that the equipment meets the excavator's specifications and weight requirement.

(3) Without mounting bracket.

Simex does not accept responsibility or liability for the information provided. Technical modifications may vary without prior notice.



CHD



2.5 - 15 TON

CHAIN TRENCHERS

CHD 90SB | CHD 120SB | CHD 90B
CHD 120B | CHD 150B

FOR EXCAVATOR

CHD chain trenchers for excavator booms are designed for set-section trenching on natural soils. The discharge screw on the right-hand side and the trench clearing device make sure the trench is always kept clean. Models 90S B and 120S B are recommended for soft soils.

WATCH THE VIDEO

Scan the QR code using your smartphone

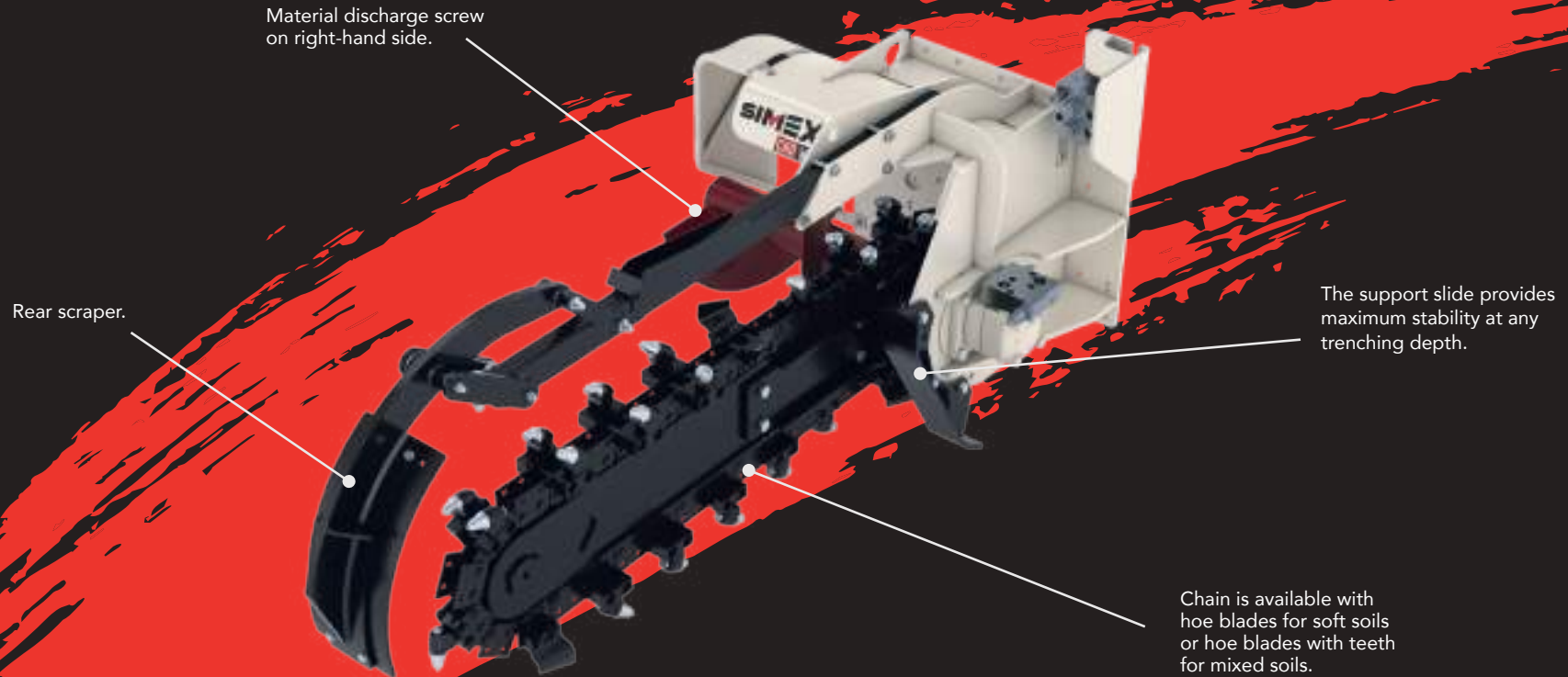

Material discharge screw on right-hand side.

Rear scraper.

The support slide provides maximum stability at any trenching depth.

Chain is available with hoe blades for soft soils or hoe blades with teeth for mixed soils.

Scan the QR code using your smartphone



TECHNICAL DATA			FOR SOFT SOILS		FOR MIXED SOILS		
			CHD 90S B	CHD 120S B	CHD 90B	CHD 120B	CHD 150B
Maximum trench depth	A	mm inch	900 35	1200 47	900 35	1200 47	1500 59
Standard trench width		mm inch	150 6	150 6	150 6	150 6	150 6
Optional trench width		mm inch	100 - 200 4 - 8	100 - 200 4 - 8	200 - 250 8 - 10	200 - 250 8 - 10	200 8
Scraper			mechanical with spring	mechanical with spring	mechanical with spring	mechanical with spring	mechanical with spring
Operating weight (1) (2)		kg lbs	260 570	425 936	525 1150	590 1300	640 1410
Required oil flow		l/min gpm	35 - 95 9 - 25	60 - 115 16 - 30	60 - 120 16 - 32	70 - 140 18 - 37	90 - 160 24 - 42
Maximum oil pressure		BAR psi	240 3500	240 3500	250 3625	250 3625	250 3625
Recommended excavator weight		ton lbs	2.5 - 4.5 5500 - 9900	4.5 - 8 9900 - 17637	7 - 15 15400 - 33000	8 - 15 17600 - 33000	8 - 15 17600 - 33000

(1) The installer is responsible for ensuring that the equipment meets the prime mover's specifications and weight requirement.

(2) Without mounting bracket.

Simex does not accept responsibility or liability for the information provided. Technical modifications may vary without prior notice.

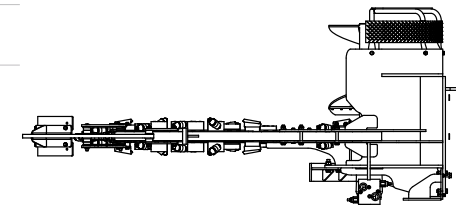
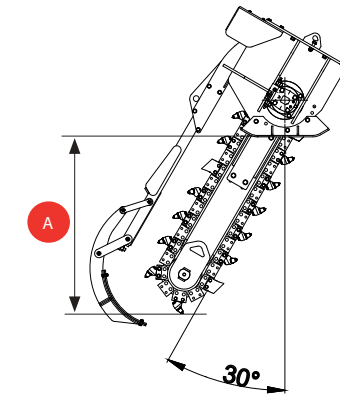

CT

Mini Exc. | Midi Excav. | 5 - 12 TON

VIBRATING WHEEL COMPACTORS

CT 2.8B | CT 3.8B

FOR EXCAVATOR

Designed for compacting trench bottoms, Simex CT vibrating wheel compactors guarantee a solid, even and well-compacted bottom that ensures maximum road safety and will not give way under the weight of farming or other heavy vehicles.

WATCH THE VIDEO

Scan the QR code using your smartphone

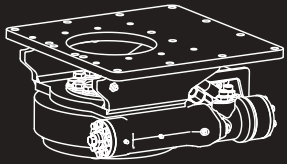

360° HYDRAULIC ROTATION (OPTIONAL): activated from the cabin, allows compaction in any position, even in the most difficult-to-reach spots.

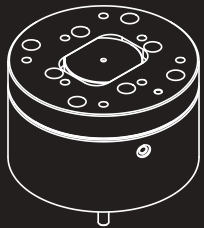

135° MECHANICAL ROTATION WITH HYDRAULIC LOCKING (OPTIONAL): Does not require additional hydraulic control.



Wheel width can be adjusted via bolted sectors that are easily changed on site.

Perfect insulation from prime mover, thanks to the reverse-rotation vibrating twin shaft positioned at centre of the wheel.



SEGMENTED WHEEL

In order to adapt to various types of section trenching, the CT vibrating compactor base wheel is fitted with bolted sectors, easily changed on site. Available widths: 150-200-250-300-350 and 400 mm.

DOWNLOAD THE UPDATED TECHNICAL BROCHURE

Scan the QR code using your smartphone



TECHNICAL DATA		CT 2.8 B	CT 3.8 B
Recommended excavator weight (1)	ton lbs	5 - 9 11000 - 20000	7 - 12 15400 - 26400
BASE WHEEL			
Width of bolted sectors A	mm inch	150 - 200 - 250 - 300 - 350 - 400 6 - 8 - 10 - 12 - 14 - 16	150 - 200 - 250 - 300 - 350 - 400 6 - 8 - 10 - 12 - 14 - 16
Working depth B	mm inch	0 - 700 0 - 28	0 - 800 0 - 32
SPECIAL WHEELS			
Wheel widths (2)	mm inch	50 - 75 - 100 2 - 3 - 4	50 - 75 - 100 2 - 3 - 4
Working depth	mm inch	0 - 350 0 - 14	0 - 465 0 - 18
Vibration frequency	Hz	30 - 40	30 - 40
Max. vertical force	kN lbf	42 9400	42 9400
Operating weight (3)	kg lbs	530 - 585 1160 - 1300	750 - 800 1650 - 1760
Required oil flow	l/min gpm	40 - 60 11 - 16	40 - 60 11 - 16
Maximum oil pressure	BAR psi	220 3200	220 3200

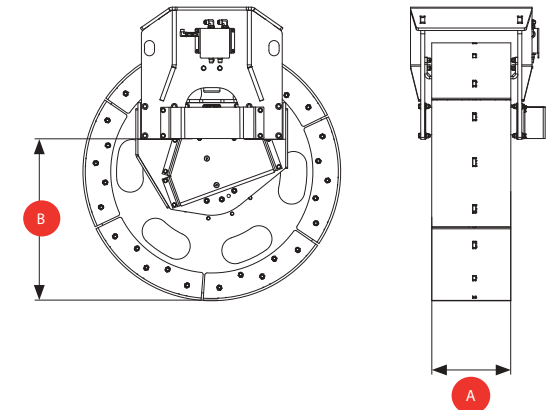

(1) The installer is responsible for ensuring that the equipment meets the prime mover's specifications and weight requirement. (2) Widths different from those indicated are available on request. (3) Without mounting bracket

Simex does not accept responsibility or liability for the information provided. Technical modifications may vary without prior notice.



MP



11 - 40 TON

CUTTER HEADS FOR PROFILING

MP 500 | MP 600 | MP 800 | MP 1000

Simex MP cutter heads for profiling, designed for excavator mounting, guarantee perfect precision finishing in applications such as: resurfacing tunnel roofs, restoring deteriorated surfaces, profiling concrete embankments and milling industrial floorings. Wheels or lateral slides allow milling thickness to remain constant in any condition.

Four models for 11 to 40-ton excavators specially designed for profiling horizontal, vertical or sloped surfaces, or where constant milling depth is required.

WATCH THE VIDEO

Scan the QR code using your smartphone



The new MP 500 and MP 600 cutter heads for profiling, designed with 11 to 25-ton excavators in mind, can be fitted with just one support wheel, perfect for applications where the frame's footprint needs to be reduced as much as possible.

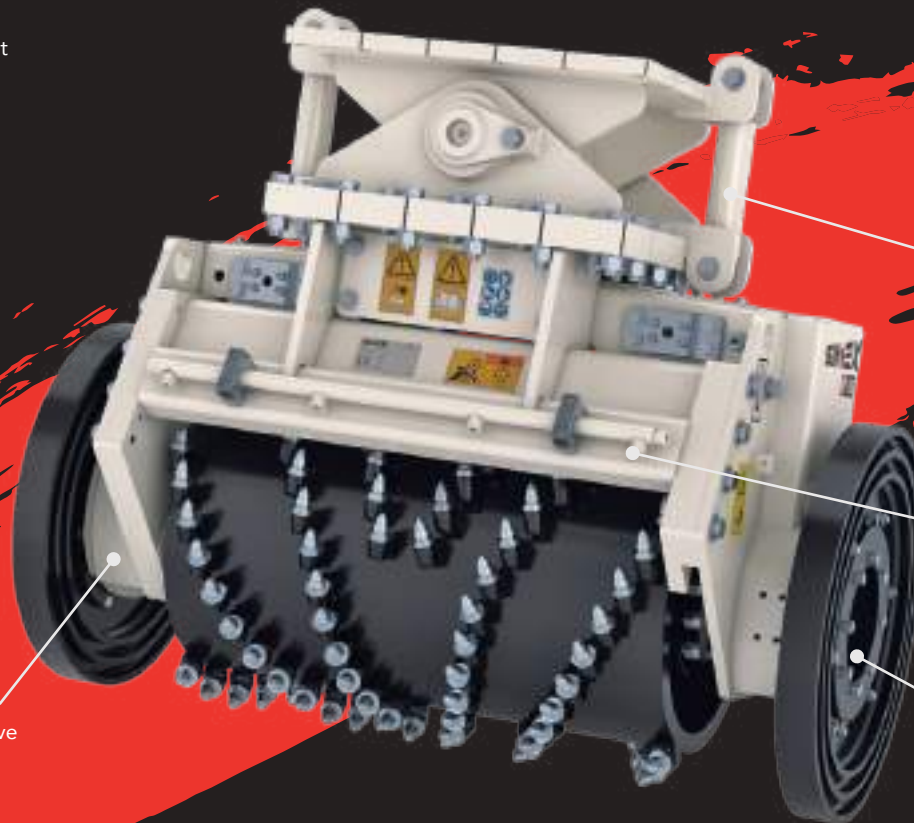
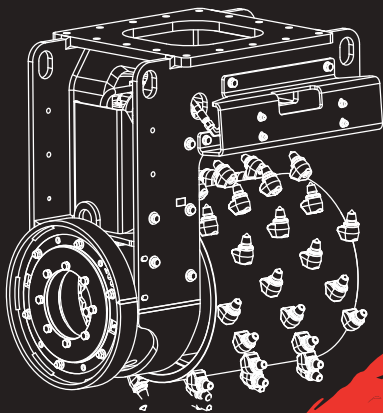

Piston motor in direct drive with the drum.

The adjustable attachment (optional), thanks to two shock absorbers, allows perfectly following the profile of surfaces to be milled while working.

Nebulizer kit: for reducing dust emission in the tunnel (optional).

Work depth is controlled by lateral wheels for constant milling thickness.



THE CUTTER HEAD FOR PROFILING TUNNELS

In tunnels, there is often widespread deterioration of the lining concrete, with cracks and gravel pockets that arise due to numerous infiltrations of water. The MP range is particularly effective in removing damaged concrete. Scarification depth and uniformity are ensured by lateral wheels, for profiling the tunnel from the crown and along the side walls, down to the ground.

DOWNLOAD THE UPDATED TECHNICAL BROCHURE

Scan the QR code using your smartphone



TECHNICAL DATA		MP 500	MP 600	MP 800	MP 1000
Recommended excavator weight (1)	ton lbs	11 - 20 22000 - 44000	16 - 25 35000 - 55000	22 - 40 48500 - 88000	22 - 40 48500 - 88000
Milling width	mm inch	500 20	600 24	800 31	1000 40
Max. working depth	mm inch	100 4	100 4	100 4	100 4
Cutting force	kN lbf	21 4720	31 7000	43.8 9850	43.8 9850
Hydraulic motors	no.	1	1	2	2
Operating weight (2)	kg lbs	900* 1080*	1050* 2314*	2000 4400	2300 5060
Required oil flow	l/min gpm	90 - 180 24 - 48	120 - 200 32 - 53	200 - 300 53 - 80	200 - 300 53 - 80
Maximum oil pressure	BAR psi	350 5100	350 5100	350 5100	350 5100

MP 500 / MP 600

MP 800 / MP 1000

OPTIONALS:

- 1 - support wheel
- 2 - adjustable attachment

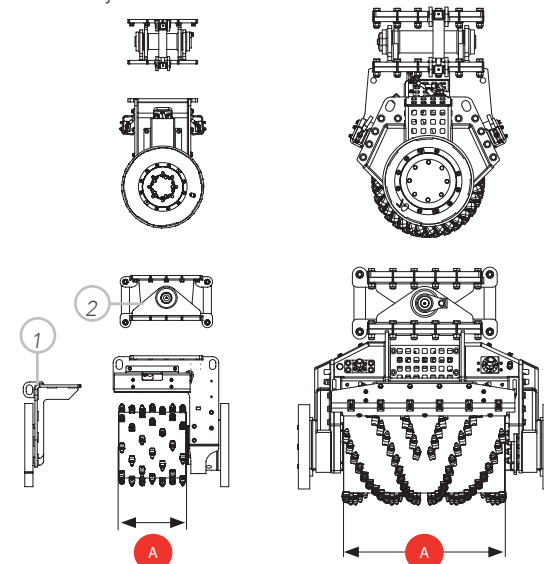

(1) The installer is responsible for ensuring that the equipment meets the excavator's specifications and weight requirement.

(2) Without mounting bracket.

(*) Weight without support wheel and adjustable attachment.

Simex does not accept responsibility or liability for the information provided. Technical modifications may vary without prior notice.



MP 1000 with aspiration (optional).

PLB PHD





 2 - 22 TON

PLANERS

PLB 200 | PLB 300 | PLB 400 | PLB 450 | PLB 600
 PHD 350 | PHD 450

WATCH THE VIDEO

Scan the QR code using your smartphone



Manual or hydraulic depth adjustment (optional).

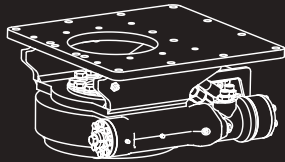

360° HYDRAULIC ROTATION (OPTIONAL):
 activated from the cabin, allows milling in any position, even in the most difficult-to-reach spots.

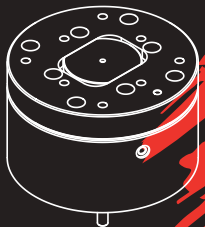

135° MECHANICAL ROTATION WITH HYDRAULIC LOCKING (OPTIONAL):
 available on models from PLB 200 to PHD 450. Does not require additional hydraulic control.

Independent RH-LH depth adjustment (PHD 350 and PHD 450).

SIMEX
 • patented •



PERFORMER

Performer: allows the operator to optimize the equipment's performance according to the forward speed of the operating machine.

Nebulizer kit (optional)

Boom-planer connection support pivoted on same rotation axis as cutter drum.

Motor in direct drive with the drum.

Designed to mill pre-set sections on hard and compact surfaces, the PLB and PHD planers for excavators are able to remove the entire layer of asphalt or cement in preparation for trenching, or are used to mill deteriorated sections for later resurfacing. These planers for excavators can work on horizontal, vertical or sloped surfaces.

AVAILABLE DRUMS AND DISKS:



STANDARD DRUMS



CEMENT DRUM
Reduced pitch compared with standard drum



SPECIAL DRUM
For widths and/or depths other than standard



CUTTING DISK

AVAILABLE TEETH:



TEETH FOR ASPHALT



TEETH FOR CEMENT



PLB 450. Removal of deteriorated concrete for later resurfacing.



PHD 450. Creating tracks in tunnels.



PHD 450. Asphalt removal in preparation for trenching.



PHD 350. Side-by-side passes.



PLB 450. Footpath milling.



PHD 450 Detailed view of milled channel.



PLB 300. Removal of asphalt layer on a road construction site

CONSTANT PLANING DEPTH

Thanks to the swinging support pivoted on the same rotation axis as the cutter drum, the attachment maintains a perfect planing surface in any condition, regardless of ground contour or the position of the attachment with respect to the prime mover.



PHD 350 AND PHD 450: INDEPENDENT DEPTH ADJUSTMENT

Independent RH-LH depth adjustment allows the slide on the opposite side of the motor to be height-adjusted independently. This ensures perfect surfaces with side-by-side passes.

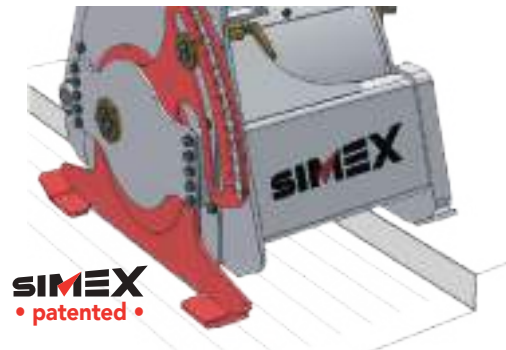

VAULT PLANING

The PLB and PHD swing planers ensure great versatility as they can work on any surface, including vertical and sloped. Such as in vault planing for creating tracks and recesses, to accommodate cables of various kinds or pipes. The planers for excavators ensure scarification depth and uniformity along the tunnel profile.



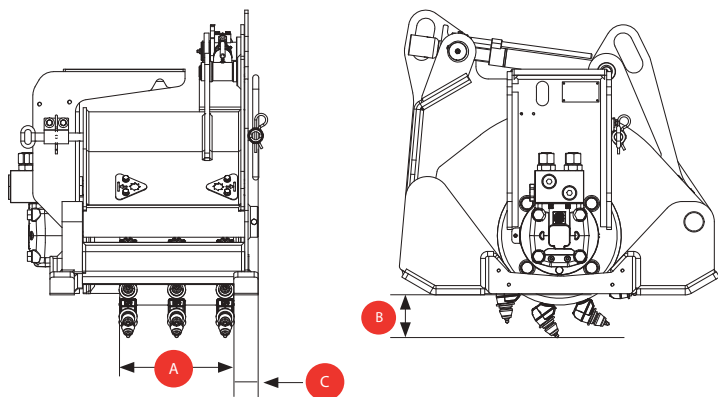

DOWNLOAD THE UPDATED TECHNICAL BROCHURE

Scan the QR code using your smartphone



TECHNICAL DATA		SINGLE DEPTH					DOUBLE DEPTH	
		PLB 200	PLB 300	PLB 400	PLB 450	PLB 600	PHD 350	PHD 450
Recommended excavator weight (1)	ton lbs	2 - 4 4400 - 8800	3 - 7 6600 - 15400	6 - 9 13000 - 20000	8 - 13 17600 - 29000	16 - 22 35000 - 48400	6 - 9 13000 - 20000	10 - 16 22000 - 35000
STANDARD DRUM								
Width	A mm inch	200 8	300 12	400 16	450 18	600 24	350 14	450 18
Depth	B mm inch	0 - 70 0 - 3	0 - 100 0 - 4	0 - 120 0 - 5	0 - 150 0 - 6	0 - 200 0 - 8	0 - 120 0 - 5	0 - 180 0 - 7
SPECIAL DRUMS UPON REQUEST								
Width	A mm inch	50 - 250 2 - 10	50 - 300 2 - 12	50 - 400 2 - 16	75 - 450 3 - 18	75 - 600 3 - 24	50 - 350 2 - 14	75 - 450 3 - 18
Max. depth	B mm inch	125 5	130 5	150 6	200 8	250 10	150 6	220 9
Independent RH-LH depth adjustment	-	-	-	-	-	-	Standard	Standard
Min. distance from footpath	C mm inch	40 (20*) 1.6 (0.8*)	50 (25*) 2 (1*)	50 (25*) 2 (1*)	60 (30*) 2.4 (1.2*)	75 (40*) 2.6 (1.4*)	50 (27*) 2 (1*)	75 (40*) 3 (1.4*)
Swinging support rotation angle	-	120°	127°	118°	120°	105°	118°	102°
Operating weight	kg lbs	185 407	390 860	515 1130	710 1560	1150 2530	530 1160	900 1980
Required oil flow	l/min gpm	30 - 50 8 - 13	45 - 75 12 - 20	55 - 90 15 - 24	75 - 140 20 - 37	120 - 200 32 - 53	55 - 90 15 - 24	90 - 140 24 - 37

(1) The installer is responsible for ensuring that the equipment meets the excavator's specifications and weight requirement.

(*) Upon request.

Simex does not accept responsibility or liability for the information provided. Technical modifications may vary without prior notice.

PV



1.5 - 40 TON

VIBRATING PLATE COMPACTORS

PV 300 | PV 450 | PV 600 | PV 700 | PV 850

Designed to compact any surface, Simex PV vibrating plate compactors are an excellent solution for achieving a solid, even, and well-compacted bottom that will never give way. Possibility to mount the rotation device allows compaction in any position, even in the most difficult-to-reach spots. No routine maintenance is needed. Vibrating oil bath provides for internal lubrication.

WATCH THE VIDEO

Scan the QR code using your smartphone

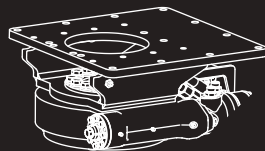

360° HYDRAULIC ROTATION (OPTIONAL):

activated from the cabin, allows compaction in any position, even in the most difficult-to-reach spots.

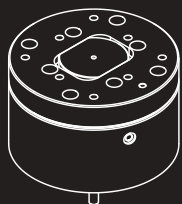

135° MECHANICAL ROTATION WITH HYDRAULIC LOCKING (OPTIONAL):

available on models PV 300, PV 450, PV 600. Does not require additional hydraulic control.



End-of-stroke pad

Flow and pressure limiting valve ensures perfect coupling with variety of excavators.

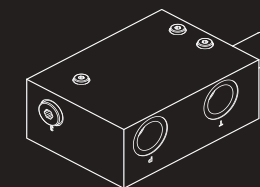

Central vibrating unit, powered by hydraulic motor

SIMEX
• patented •

Scan the QR code using your smartphone



TECHNICAL DATA		PV 300	PV 450	PV 600	PV 700	PV 850
Recommended excavator weight	ton lbs	1.5 - 5 3300 - 11000	4 - 10 8800 - 22000	6 - 15 13000 - 33000	12 - 25 26400 - 55000	20 - 40 44000 - 88000
Plate dimensions	A x B mm inch	290 x 780 11 x 31	440 x 850 17 x 34	550 x 920 22 x 36	690 x 1160 27 x 45	840 x 1220 33 x 48
Vibration frequency	n/min vpm	2100	2100	2100	2100	2100
Compaction force	kN lbf	15 3400	27 6000	34 7650	75 16900	93 20900
Weight without mounting bracket (1)	kg lbs	185 410	310 685	415 915	740 1630	1005 2215
Required oil pressure	BAR psi	160 2320	160 2320	160 2320	160 2320	160 2320
Required oil flow	l/min gpm	30 8	57 15	75 20	110 29	155 41

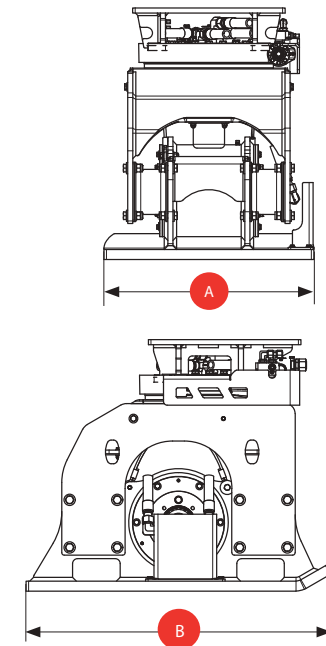

(1) The installer is responsible for ensuring that the equipment meets the excavator's specifications and weight requirement. Simex does not accept responsibility or liability for the information provided. Technical modifications may vary without prior notice.



Compaction of trenches after laying underground utilities



Compaction of building foundations



360° Hydraulic rotation (optional)

RWE



1.5 - 18 TON

WHEEL SAWS

RWE 15 | RWE 20 | RWE 30 | RWE 35 | RWE 50

RWE wheel saws, designed for excavator mounting, are for cutting and small-section trenching in 100-500 mm working depths. Depending on model, RWEs are specially indicated for mini- and micro-trenching on hard and compact surfaces, such as asphalt and cement, for fibre optic cable installation; or for making longitudinal cuts on concrete industrial floors for demolition and removal purposes.

WATCH THE VIDEO

Scan the QR code using your smartphone



PERFORMER

Performer: allows the operator to optimize the equipment's performance according to the forward speed of the operating machine.

RWE 15, RWE 30 AND RWE 35: Available also for skid steer mounting, with connection frame and side shift. Fitted with a tilting self-levelling system thanks to the jointed support that rotates on the axis of the drum.



The self-levelling system ensures constant trench depth in any condition, regardless of ground contour or the position of the attachment with respect to the prime mover.

Depth adjustment (RWE 50)

CLEAN TRENCH: the special design of outlets allows trench to be cleared efficiently at the depth programmed.

RWE 50: disk with removable, interchangeable segments allows quick variation of the trench width while maintaining the same base wheel.

SIMEX
• patented •

Scan the QR code using your smartphone



TECHNICAL DATA		RWE 15	RWE 20	RWE 30	RWE 35	RWE 50
Recommended excavator weight (1)	ton lbs	1.5 - 3.5 3300 - 7700	2.5 - 5 5500 - 11000	5 - 10 11000 - 22000	8 - 13 17600 - 28600	14 - 18 30800 - 39600
Trench width	A mm inch	25 - 30 - 40 - 50 1 - 1.2 - 1.6 - 2	25 - 30 - 40 - 50 1 - 1.2 - 1.6 - 2	25 - 30 - 40 - 50 - 80 1 - 1.2 - 1.6 - 2 - 3.2	25 - 30 - 40 - 50 - 80 1 - 1.2 - 1.6 - 2 - 3.2	50 - 80 - 100 - 120 2 - 3.2 - 4 - 4.7
Trench depth	B mm inch	100 - 125 - 150 4 - 5 - 6	200 8	200 - 250 - 300 8 - 10 - 12	250 - 300 - 350 10 - 12 - 14	from 300 to 500 12 - 20
Depth adjustment		mechanical manual	-	mechanical manual	mechanical manual	mechanical manual hydraulic (optional)
Operating weight (2)	kg lbs	145 (3) - 160 (4) 320 (3) - 353 (4)	125 275	490 (3) - 550 (5) 1080 (3) - 1210 (5)	700 (3) - 790 (5) 1540 (3) - 1740 (5)	1390 3060
Required oil flow	l/min gpm	30 - 65 8 - 17	30 - 75 8 - 20	60 - 115 16 - 30	90 - 130 24 - 34	100 - 160 26 - 42
Maximum oil pressure	BAR psi	250 3625	250 3625	300 4350	300 4350	350 5100

(1) The installer is responsible for ensuring that the equipment meets the excavator's specifications and weight requirement.

(2) Without mounting bracket.

(3) With trench wheel width: 25 mm.

(4) With trench wheel width: 50 mm.

(5) With trench wheel width: 80 mm.

Simex does not accept responsibility or liability for the information provided. Technical modifications may vary without prior notice.

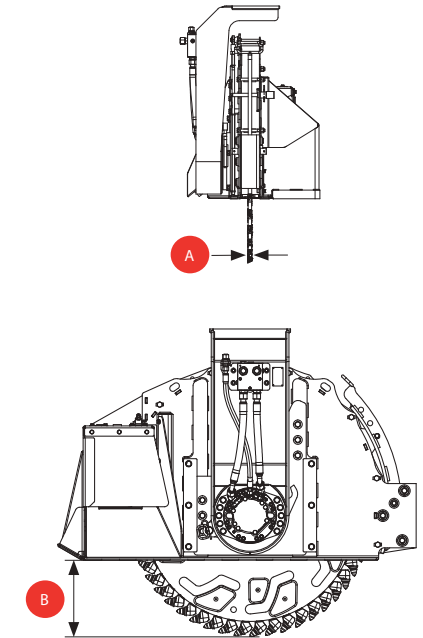

RWE



Excav. 25 - 75 TON

WHEEL SAWS FOR DEMOLITION

RWE 60 | RWE 80 | RWE 90 | RWE 100

The RWE 60-80-90-100 wheel saw models are designed for heavy excavators to cover all those job-sites where cuts need to be made on horizontal or vertical surfaces and in the presence of very resistant and abrasive materials. These wheel saw models intended for heavy excavators, make set-section cuts on hard and compact surfaces: asphalt, cement, rock. Ideal for demolition and underwater works.

WATCH THE VIDEO

Scan the QR
code using your
smartphone



Cutting disks for 600-800-900-1000 mm
working depths.



Flow and pressure limiting
valve ensures coupling
versatility with variety of
excavators.

Two high-displacement, radial piston
hydraulic motors, in direct drive with
the drum, guarantee high torque and
generate high tooth force.

Scan the QR code using your smartphone



TECHNICAL DATA		RWE 60	RWE 80	RWE 90	RWE 100
Recommended excavator weight (1)	ton lbs	25 - 45 61000 - 99000	50 - 75 110000 - 165000	50 - 75 110000 - 165000	50 - 75 110000 - 165000
Width	A mm inch	100 - 130 - 200 4 - 5 - 8	130 - 200 5 - 8	130 - 200 5 - 8	130 - 200 5 - 8
Depth	B mm inch	600 24	800 32	900 35	1000 39
Maximum applicable power	kW	100	220	220	220
Max. cutting force (3)	kN lbf	23 5170	55.7 12520	50.2 11285	44.8 9891
Operating weight (2)	kg lbs	2550 5600	5000 11000	5550 12200	6175 12350
Required oil flow	l/min gpm	200 - 350 53 - 93	400 - 450 106 - 120	400 - 450 106 - 120	400 - 450 106 - 120
Maximum oil pressure	BAR psi	350 5100	350 5100	350 5100	350 5100

(1) The installer is responsible for ensuring that the equipment meets the excavator's specifications and weight requirement.

(2) Without mounting bracket.

(3) Cutting force at 350 bar pressure.

Simex does not accept responsibility or liability for the information provided. Technical modifications may vary without prior notice.

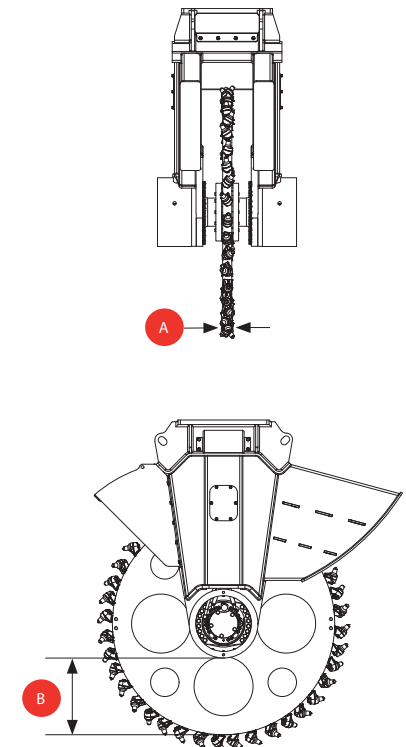

TF



2.5 - 75 TON

DOUBLE-DRUM CUTTER HEADS

TF 200 | TF 450 | TF 650 | TF 850 | TF 1100 | TF 2100 | TF 2500 | TF 3100

WATCH THE VIDEO

Scan the QR code using your smartphone

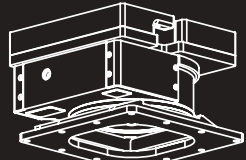

PARALLEL HYDRAULIC ROTATION for TF 450 and 650.

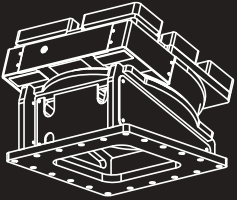

TILTED HYDRAULIC ROTATION for TF 850/1100/2100.

learn more on page 11

INCREASED PRODUCTIVITY AND MAXIMUM PRECISION: cutter head can be rotated 90° with respect to mounting bracket (thanks to square holes of coupling plate).

FILTER ON FEED LINE prevents impurities from entering the motor.

Hose hook-up on both cabin side (standard) and front.

MILLED MATERIAL IS DISCHARGED FROM THE TRENCH WITHOUT GETTING STUCK IN THE FRAME due to special shape.

DRUMS AND TEETH FOR ANY APPLICATION, designed to achieve the highest performance according to the required application. Multiple tooth geometries available for working on different materials.

HIGH TORQUE AND HIGH PERFORMANCE guaranteed by integrated high displacement hydraulic piston motor in direct drive with the drums. Shaft transmits motion only and bears no load thanks to double support bearings for each drum.

REPLACEABLE ANTI-WEAR PLATES

MECHANICAL GASKETS FITTED ON DRUMS SEAL AGAINST DUST also when attachment is submerged into the ground, even in muddy conditions.

SIMEX
• patented •

The Simex TF double drum cutter heads are ideal for trenching, profiling rock and cement walls, tunnelling, quarrying, demolition, dredging, finishing operations and underwater works. They are highly effective where conventional excavation systems are too weak and percussion ones have little effect.

AVAILABLE DRUMS:



HP (STANDARD)
Allows deep penetration even into hard materials



GP (OPTIONAL)
Recommended for wall profiling and various types of jobs



WP (OPTIONAL)
Special drum for finishing and profiling



HPP (OPTIONAL)
Special drums for mixing soils

AVAILABLE TEETH:



STANDARD
For mixed materials



OPTIONAL
For milling very hard materials



OPTIONAL
For wood



OPTIONAL
For tilling

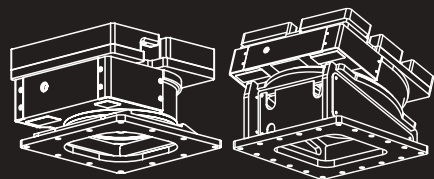

360° HYDRAULIC ROTATION

Hydraulic rotation allows the operator to always find the ideal working position. Increased productivity. Maximum precision.

learn more on page 11

UTILITIES

TF 850 with 360° hydraulic rotation. In trenching, hydraulic rotation allows operator to find the ideal working position.



CONDUITS

TF 850. Trench excavation for laying underground utilities and pipes.



VERTICAL PROFILING

TF 450. Precision vertical milling for building works.

TUNNELLING

TF 1100. Removal of deteriorated concrete for later shotcrete application.



QUARRYING

TF 1100. Extraction of calcium carbonate in limestone quarry.



TRENCHING

TF 1100. Trenching with the narrowest possible width (A=B).



DIRECT DRIVE AND HIGH TORQUE

The direct drive hydraulic piston motor directly delivers power to the drums without mechanical transmission components, thus guaranteeing high torque and high performance.

Shaft transmits motion only and bears no load thanks to double support bearings for each drum.

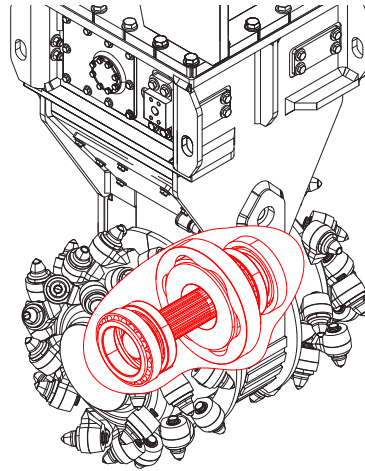

MAXIMUM PROTECTION AND ZERO ROUTINE MAINTENANCE

Filter on feed line and filter on drainage line, both integrated, protect the hydraulic system from any external impurities, which can damage or reduce the performance of both the excavator and the equipment. (In TF 200 and TF 450 models the filter is only on the feed line). Additional protection from pressure peaks is ensured on drainage line by an accumulator and a fuse, an on feed line by a flow limiting valve. The latter also allows easy coupling with various excavator models and sizes, facilitating installation and calibration operations. The direct drive motor does not require lubrication or other types of routine maintenance.

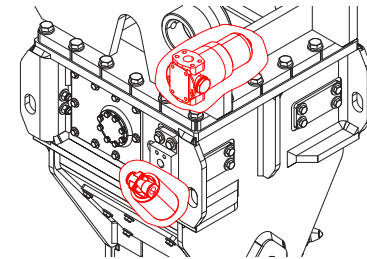

UNDERWATER WORKS

TF 3100. Trench excavation for laying water mains pipes.

CRUSHING TREE TRUNKS

TF 850. Crushing tree trunks with special teeth made for wood.

DESIGN AND HIGH PERFORMANCE

The frame's particular shape allows reducing the distance between the drums improving the total working width. Furthermore, milled material is discharged from the trench without getting stuck in the structure due to perfect symmetry of the frame, which also allows hoses to be hooked up at sides and front (except for TF 200 and TF 450 models). Replaceable anti-wear plates. In addition, the mechanical gaskets fitted on the drums ensure maximum resistance to dust and any external agents, allowing the equipment to work completely submerged into the ground or water up to a maximum depth of 30 metres.

A TRUE ALTERNATIVE TO TRADITIONAL SYSTEMS

The TF cutter heads are especially useful where conventional excavation systems are too weak and percussion systems have little effect. The low vibrations and seamless milling make the TF cutter head particularly suitable in applications requiring selective breaking of the rock mass, while at the same time producing crushed material of a particle size suitable for on-site reuse or transport elsewhere.



SOFT SOIL	MEDIUM SOIL	HARD SOIL Fractured Rock	VERY HARD SOIL Compact Rocks
BUCKET			
	RIPPER		
		CUTTER HEAD TF - SIMEX	
			BREAKER
			EXPLOSIVES

PRODUCTIVITY ESTIMATE

RATIO BETWEEN CUTTING EFFICIENCY AND COMPRESSIVE STRENGTH

The graph below gives an approximate indication of the ratio between cutting efficiency of each cutter head model in optimal conditions and the unconfined compressive strength of the rock.

Since many variables exist regarding the material (**fracturing, weathering, ductility**, etc.), the prime mover and the operability, the ratio should be understood as only an approximation of cutting efficiency. The actual production may be estimated after all noted variables are taken into account.

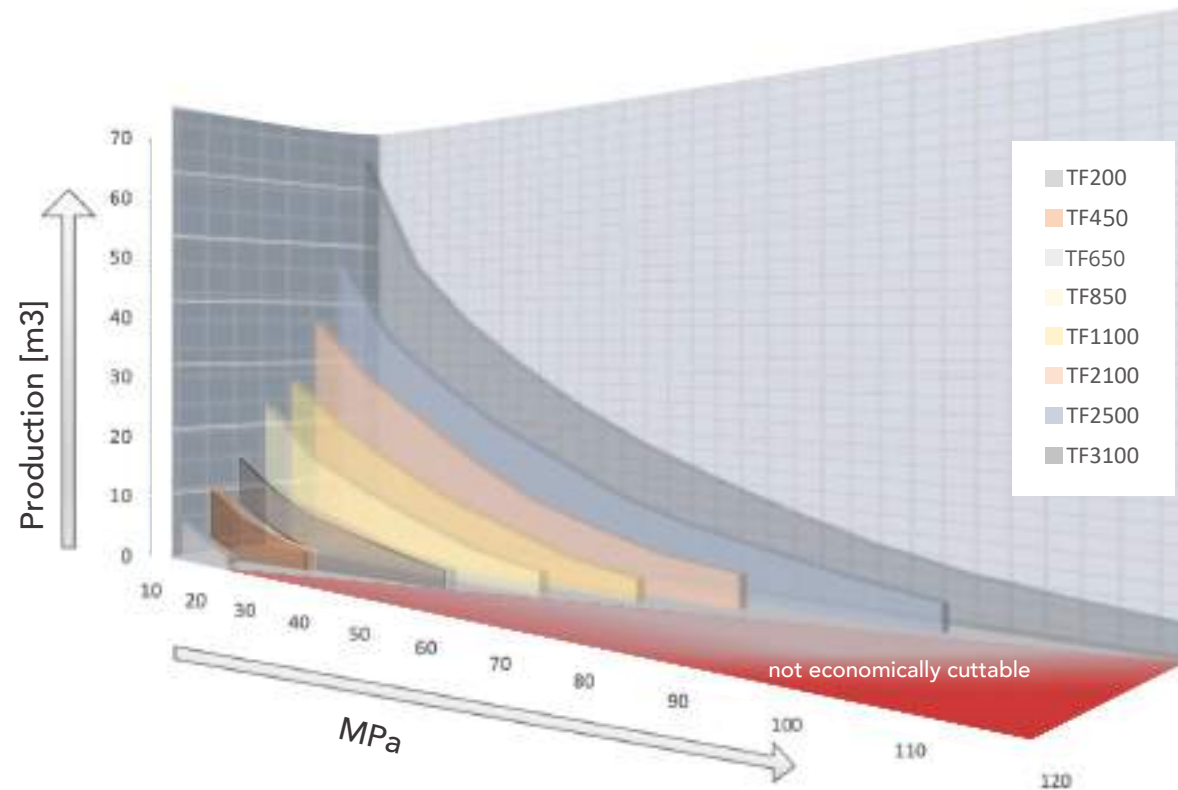

CALCULATION OF HOURLY PRODUCTION

Our team of experts has created a tool to help you calculate the theoretical hourly production, guiding you in choosing the most appropriate drum cutter for the type of material to be worked. Scan the QR code on the side with your smartphone to access the calculator for hourly production.



BUILDINGS AND INFRASTRUCTURE

TF 3100. Rock wall profiling for later real estate development.



EXTREME CONDITIONS

TF 1100. Trenching on frozen ground in permafrost conditions (-40°).



EARTHWORKS

TF 850. Excavation for the construction of foundations for pillars.

PRODUCTIVITY: A FEW APPLICATION EXAMPLES

TRENCH EXCAVATION FOR LAYING UNDERGROUND UTILITIES

Job: Trench excavation with TF 850 for later connection to sewers

Material: metamorphic rock with schist texture

Forward speed: 10 linear metres per hour, depth: 80 cm.



PROFILING NATURAL WALL IN CONSTRUCTION FIELD

Job: profiling natural wall in a construction site with TF 2100 and TF 3100

Material: hard and compact sedimentary conglomerate, 80-90 MPa

Production: 10-15 m³/h



DEMOLITION OF INDUSTRIAL FLOORS

Job: Dismantling of industrial concrete flooring, 25 MPa with TF 2100

Material: Reinforced concrete

Production: 40-45 m²/h



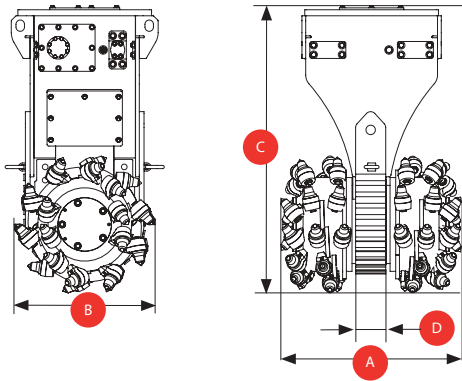

DOWNLOAD THE UPDATED TECHNICAL BROCHURE

Scan the QR code using your smartphone



TECHNICAL DATA		TF 200	TF 450	TF 650	TF 850	TF 1100	TF 2100	TF 2500	TF 3100
Recommended excavator weight	ton lbs	2.5 - 7 5500 - 15500	6 - 12 13000 - 26500	9 - 16 19800 - 35200	14 - 22 30800 - 48500	20 - 34 44000 - 75000	28 - 45 61700 - 99000	40 - 55 88000 - 121000	50 - 75 110000 - 165400
Weight without mounting bracket (1)	kg lbs	300 660	470 1050	650 1430	1100 2420	1340 2950	2380 5240	2700 5950	2940 6470
Nominal power	hp (kW)	40 (30)	55 (40)	68 (50)	95 (70)	122 (90)	163 (120)	205 (150)	250 (185)
Rotation torque	kNm lbf.ft	2.8 2080	5.1 3760	7.4 5450	12.1 8920	20 14750	26.7 19700	36.1 27600	48 35400
Cutting force	kN lbf	15.1 3400	22.5 5100	30.5 6850	40.2 9000	61 13700	71 16000	96.4 21600	128 28700
Maximum pressure (2)	BAR psi	350 5100	350 5100	350 5100	400 5800	400 5800	400 5800	400 5800	400 5800
Required oil flow	l/m gpm	45 - 80 12 - 21	65 - 120 17 - 32	90 - 150 24 - 40	140 - 190 37 - 50	170 - 250 45 - 66	240 - 340 63 - 90	280 - 400 74 - 105	350 - 500 92 - 132
360° Hydraulic rotation optional		-	yes	yes	yes	yes	yes	-	-
Drum width (HP) standard	mm inch	565 22	625 25	700 28	800 32	865 34	965 38	1000 40	1270 50
Drum width (GP) optional	mm inch	-	-	-	890 36	1000 40	1100 43	1150 45	1350 53
Drum width (WP) optional	mm inch	650 26	750 30	850 34	920 36	1200 47	-	-	-
Drum diameter HP	mm inch	380 15	450 18	500 20	595 24	660 26	750 30	750 30	750 30
Height without mounting bracket	mm inch	840 33	970 38	1005 40	1270 50	1335 53	1570 62	1675 66	1825 72
Drum distance	mm inch	110 4	130 5	135 5.3	180 7	190 7.5	250 10	250 10	330 13
Tooth holder diameter	mm inch	20 0.8	22 0.9	22 0.9	38/30 1.5/1.2	38/30 1.5/1.2	38/30 1.5/1.2	38/30 1.5/1.2	38/30 1.5/1.2

(1) The installer is responsible for ensuring that the equipment meets the excavator's specifications and weight requirement.

(2) Torque and cutting force decrease with lowered operating pressure.

Simex does not accept responsibility or liability for the information provided. Technical modifications may vary without prior notice.

TFC



1.2 - 12 TON

CUTTER HEADS WITH CONTINUOUS CUTTING

TFC 50 | TFC 100 | TFC 400 | TFC 600

WATCH THE VIDEO

Scan the QR code using your smartphone



Ideal for trenching as well as wall profiling.

The double drum system plus central chain makes the front continuous cutting profile without gaps at centre.

A versatile attachment, it may be used in various application fields.



SIMEX
• patented •

The TFC cutter heads with continuous cutting are specifically designed for mounting on mini-excavators and excavators up to 12 tons. They feature an innovative system without gaps at centre or side footprints and are ideal for finishing flat surfaces and trenches. Quiet and precise in the work zone, they do not intrude on the surrounding area. Versatile and high-performing, they can also be utilized for crushing roots and tree trunks, milling asphalt and cement, milling plaster.

DRUMS

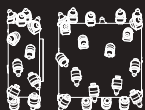

STANDARD
For TFC 50



STANDARD
For TFC 100



STANDARD
For TFC 400



STANDARD
For TFC 600

TEETH



STANDARD
For TFC 50



STANDARD
For TFC 100



STANDARD
For TFC 400



STANDARD
For TFC 600

SUPPORT WHEELS (OPTIONAL)

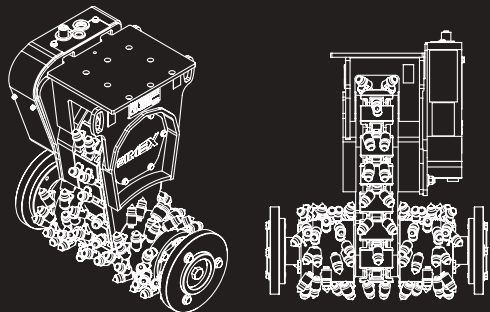

Models TFC 50 and TFC 100 may be fitted with lateral disks to ensure perfect control on the thickness of the milled material.



VERTICAL PROFILING

TFC 400. Vertical profiling on rock wall for later consolidation.



CONTROLLED REMOVAL

TFC 100. Removal of plaster on wall with thickness control thanks to side wheels.



CONDUITS

TFC 400. Trench excavation for laying water mains pipes.



SCARIFICATION

TFC 100. Scarification of concrete pillars.



ROADWORKS

TFC 50. Selective removal of deteriorated asphalt for later resurfacing.



CONDUITS

TFC 400. Trench excavation for laying underground utilities.



CRUSHING TREE TRUNKS

TFC 100. Crushing roots and tree trunks.

CONTINUOUS CUTTING WITH CENTRAL CHAIN

TF technology is naturally completed by the TFC range, for excavators in the 1.2-12 ton category. It features a double drum system plus central chain, which makes the front continuous cutting profile without gaps at centre between the drums. Ideal for finishing flat surfaces and for creating set-section trenches.



TRENCHING

With trench excavations it is possible to work at great depths (the only limit being the excavator boom) since thanks to the continuous cut given by the central chain, movement will only be vertical, allowing the operator to keep the excavation width as small as possible. With this method, it will no longer be necessary to move the boom left and right to remove portions of unmilled material that normally form between the drums.



WALL PROFILING

Similarly to flat surfaces, with the TFC is possible to do narrow millings as narrow as the cutter head profile is also on vertical walls or tunnel vaults, and are therefore particularly indicated for laying utilities, building elements, formworks, etc. When profiling walls and tunnels, the central chain allows side-by-side millings using the entire cutting width profile, avoiding any unmilled material to be left, granting more productivity in less time.



VARIOUS APPLICATION FIELDS

Quiet and precise in the work area, their versatility ensures high performance in various application fields, such as:

- Trench excavation
- Scarification and profiling of flat surfaces and vertical walls
- Removal of deteriorated concrete in tunnel
- Crushing of roots and tree trunks
- Precision road maintenance (finishing around manholes and footpaths).



Scan the QR code using your smartphone

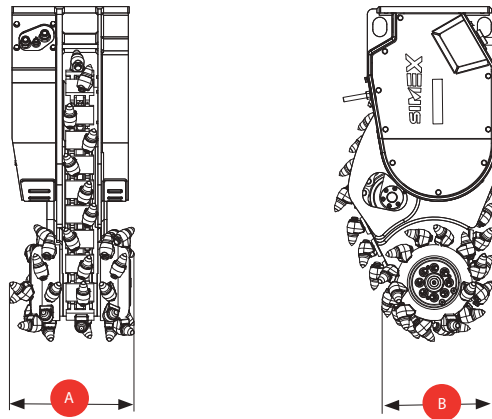

TECHNICAL DATA		TFC 50	TFC 100	TFC 400	TFC 600
Width (cutting profile)	A mm inch	370 15	480 19	440 / 500 (*) 17 / 20 (*)	490 / 540 (*) 20 / 21 (*)
Drum diameter (cutting profile)	B mm inch	230 9	260 10	420 16	480 19
Weight (1)	kg lbs	90 200	170 375	400 880	670 1470
Recommended excavator weight (2)	ton lbs	1.2 - 3.0 2640 - 6600	2.5 - 4.5 5600 - 9900	6 - 10 13000 - 22000	9 - 12 20000 - 26400
Required oil flow (3)	l/min gpm	20 - 40 5 - 10	30 - 60 8 - 16	65 - 115 17 - 30	90 - 150 24 - 40
Maximum oil pressure (4)	BAR psi	250 3625	300 4350	300 4350	300 4350
Max. torque	Nm lbf.ft	600 (at 250 bar) 445 (at 3625 psi)	1060 (at 300 bar) 780 (at 4350 psi)	3800 (at 300 bar) 2800 (at 4350 psi)	5900 (at 300 bar) 4350 (at 4350 psi)
Max. cutting force	N lbf	5100 (at 250 bar) 1145 (at 3625 psi)	8100 (at 300 bar) 1820 (at 4350 psi)	18500 (at 300 bar) 4160 (at 4350 psi)	24500 (at 300 bar) 5500 (at 4350 psi)

(*) Drums optional.

(1) Without mounting bracket.

(2) The installer is responsible for ensuring that the equipment meets the excavator's specifications and weight requirement.

(3) RPM and cutting speed decrease with lowered oil flow.

(4) Torque and cutting force decrease with lowered operating pressure.

Simex does not accept responsibility or liability for the information provided. Technical modifications may vary without prior notice.

TFU



1.5 - 25 TON

UNIVERSAL CUTTER HEADS

TFU 200 | TFU 250 | TFU 350 | TFU 450
TFU 550 | TFU 650

The TFU universal cutter heads for excavators are versatile attachments that can be used on horizontal, vertical or sloped surfaces, for scarification, profiling, cutting and trenching. In fact, they may be fitted with cutting drum or cutting wheel for various widths and depths.

WATCH THE VIDEO

Scan the QR code using your smartphone



360° Rotation (optional).

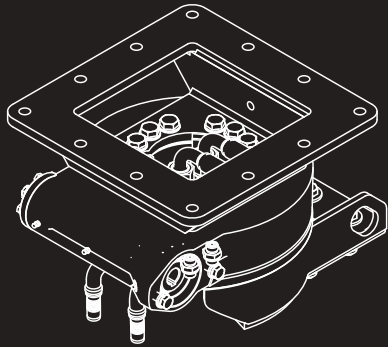

May be fitted with either cutting drum or wheel.



Flow and pressure limiting valve (TFU 550 and TFU 650).

Motor in direct drive with the drum.



MAY BE FITTED WITH EITHER CUTTING DRUM OR WHEEL

The universal cutter heads may be fitted with a cutting drum for scarification of cement, asphalt, or for profiling vertical or sloped surfaces. The cutting wheel, instead, may be used for trenching and small excavations of various depths and widths on hard and compact surfaces.



DOWNLOAD THE UPDATED TECHNICAL BROCHURE

Scan the QR code using your smartphone



DRUM

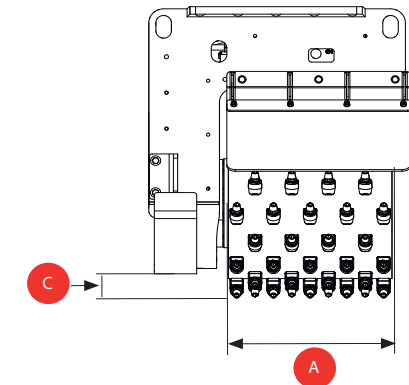

CUTTING WHEEL

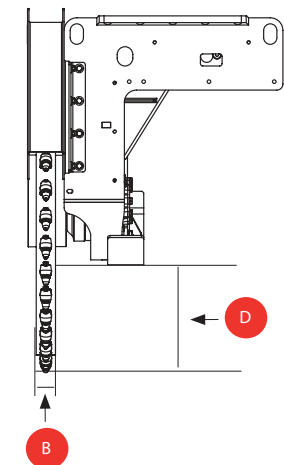

TECHNICAL DATA

		TFU 200	TFU 250	TFU 350	TFU 450	TFU 550	TFU 650
Recommended excavator weight (1)	ton lbs	1.5 - 3.5 3300 - 7700	3 - 6 6600 - 13200	5 - 11 11000 - 24200	9 - 15 20000 - 33000	11 - 18 24200 - 39600	15 - 25 33000 - 55000
DRUM							
Standard width	mm inch	200 8	250 10	350 14	450 18	550 22	650 26
Max. depth	mm inch	60 2.4	70 2.8	100 4	120 5	150 6	200 7
CUTTING WHEELS							
Width	mm inch	30 - 50 1 - 2	30 - 50 - 80 1.2 - 1 - 3	50 - 80 - 100 2 - 3 - 4	50 - 80 - 100 - 120 2 - 3 - 4 - 5	80 - 120 - 150 3 - 5 - 6	100 - 150 - 200 4 - 6 - 8
Max. depth	mm inch	150 6	200 8	250 10	300 12	350 14	450 18
Maximum pressure	BAR psi	250 3625	350 5100	350 5100	350 5100	350 5100	350 5100
Required oil flow	l/m gpm	25 - 50 7 - 14	40 - 80 11 - 22	60 - 115 16 - 30	80 - 140 21 - 37	110 - 190 29 - 50	150 - 250 40 - 66

(1) The installer is responsible for ensuring that the equipment meets the excavator's specifications and weight requirement.

Simex does not accept responsibility or liability for the information provided. Technical modifications may vary without prior notice.

TFV



7 - 25 TON

VERTICAL CUTTER HEADS

TFV 400 | TFV 600 | TFV 850

Designed for mounting on excavator booms, the TFV vertical cutter heads are ideal for profiling, excavating irregular shapes, cropping and cleaning pillars, trenching smaller widths, removing iron and steel residues, or mixing soils.

WATCH THE VIDEO

Scan the QR code using your smartphone



Flow control valve

Filter on feed line



Radial piston motor generates high cutting force

Drum fitted with mechanical gaskets for underwater works



CROPPING REINFORCED CONCRETE PILLARS

The vertical cutter head is often used in cropping pole heads in reinforced concrete, in order to strip the rebar. The cutter head ensures precision in the work area, while at the same time producing crushed material of a particle size suitable for immediate transfer to disposal centres or on-site reuse.

DOWNLOAD THE UPDATED TECHNICAL BROCHURE

Scan the QR code using your smartphone



TECHNICAL DATA		TFV 400	TFV 600	TFV 850
Recommended excavator weight (1)	ton lbs	7 - 12 15400 - 26400	10 - 18 22000 - 39600	15 - 25 33000 - 55000
Speed of rotation	rpm	100	90	80
Diameter A	mm inch	380 15	420 17	450 18
Height without mounting bracket B	mm inch	1000 40	1100 43	1200 48
Max. power	kW (hp)	37 (50)	50 (68)	60 (82)
Operating weight (2)	kg lbs	245 540	400 880	570 1255
Required oil flow	l/min gpm	60 - 110 16 - 29	100 - 140 26 - 37	120 - 170 32 - 45
Maximum pressure	BAR psi	350 5100	350 5100	350 5100

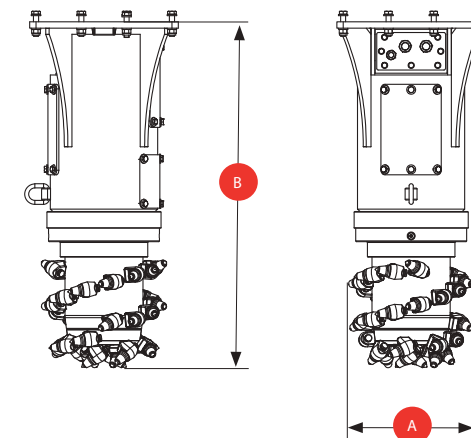

(1) The installer is responsible for ensuring that the equipment meets the excavator's specifications and weight requirement.

(2) Without mounting bracket attaching to prime mover.

Simex does not accept responsibility or liability for the information provided. Technical modifications may vary without prior notice.



VSE

Mini Exc. | Midi Exc. | Excav. | Backhoe 1.5 - 50 TON

SCREENING BUCKETS

VSE 2 | VSE 3 | VSE 5 | VSE 10 | VSE 20 | VSE 30 | VSE 40 | VSE 50

WATCH THE VIDEO

Scan the QR code using your smartphone



INSTANT ADJUSTMENT OF OUTPUT SIZE (EXCEPT VSE 2, VSE 3 AND VSE 5).

With a simple control in the cabin, the Simex designed and patented mechanism allows the shafts to be distanced or closed by means of a hydraulic system. This feature makes it possible to vary the output size of the screened material instantly.

Alternatively, if the excavator is fitted with a double-acting auxiliary system, this adjustment is made using joysticks.

PRODUCTIVITY

Shafts are composed of elements with varying-sized disks that produce an intense whirling of the material to be screened.

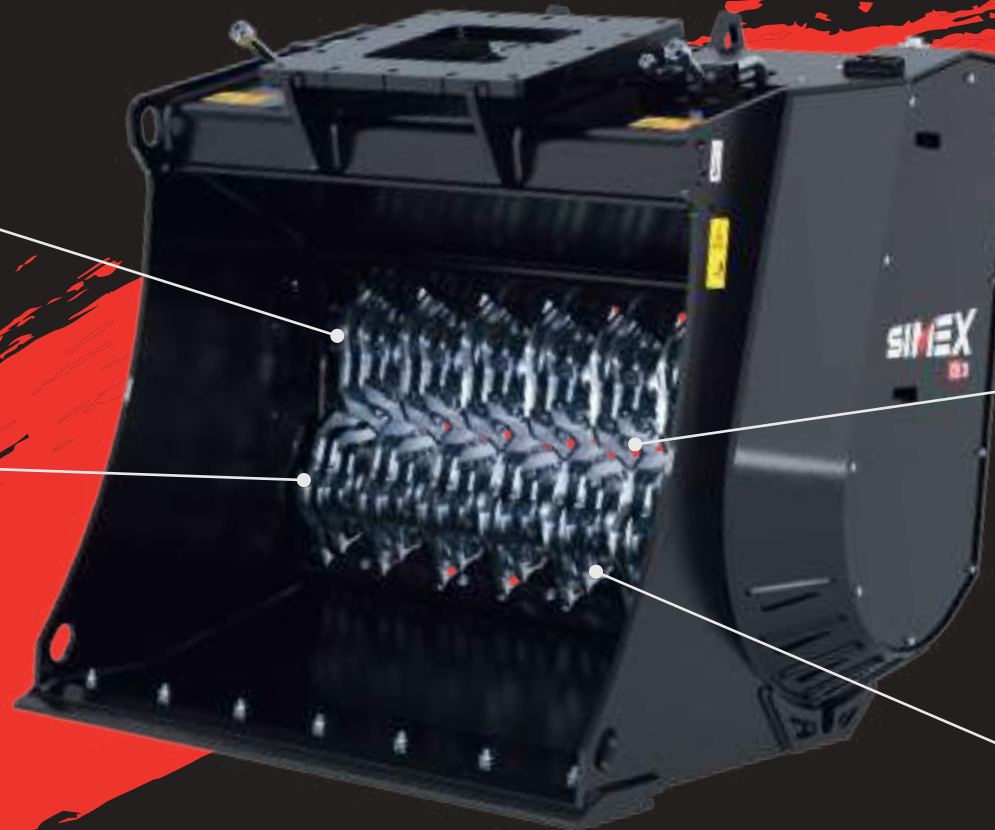

FIT: NEW SCREENING TOOLS (EXCEPT VSE 2 AND VSE 3)

Easily replaceable screening elements, with different profiles for processing different materials. Tool replacement is quick and does not require shaft disassembly.

EASY TO LOAD

Wide mouth, shaped as standard bucket.



SIMEX
• patented •

Designed for separating different-sized materials directly on the work site, Simex VSE screening buckets for excavators are unique for their easy loading, very simple operation and high productivity. The exclusive Simex patent allows instant adjustment of output size of the screened material in only seconds via a control in the operator cabin.

FIT: THE SIMEX-PATENTED TOOL SYSTEM

The patented FIT tool system, which is modular and customizable, allows multiple configurations depending on the materials to be screened. Tools are easily and quickly replaced, thanks to interlocking elements with no welding, which means saving up to 75% in maintenance costs.

AVAILABLE CONFIGURATIONS:



RECYCLING CONFIGURATION

Indicated for: dry soils, with dry clay, gravel, silt and peat.

Recommended application: backfilling excavations and pipelines. Selecting demolition aggregates.



DISREGGATION CONFIGURATION

Indicated for: topsoil, plant waste, clay and peat.

Recommended application: Screening and aeration of compost, growing medium for the landscape and horticultural sector.



MIXED CONFIGURATION

Indicated for: humid soils, mixed with stones, gravel and clay. Light crushing of demolition waste.

Recommended application: screening plant waste, soil remediation of debris, stones and roots. Selecting demolition aggregates.



AGGRESSIVE CONFIGURATION

Indicated for: separating damp and wet material that tends to adhere to stones, roots and demolition waste. Greater crushing thanks to the presence of only toothed elements.

Recommended application: screening and separation of plant waste, clayey soils, very humid or wet demolition waste.



LEARN MORE ON PAGE 50



VSE 10. Selecting excavation waste material for later reuse in backfilling water mains pipes.



VSE 20. Removal of natural soil aggregates for establishing new green areas within a construction site.

VSE 40. Construction of installation bed and later backfilling of underground conduits.

VSE 30. Soil selection and cleaning for subsequent transfer to a decontamination plant.





VSE 30. Aeration and screening of topsoil for later resale in horticultural field.



VSE 10. Separation of waste material from excavations for reuse as aggregates for road foundations.



VSE 20. Soil remediation of stones and debris for reuse in backfilling underground pipelines.

VSE 2, VSE 3 AND VSE 5: GREEN AREAS AND HORTICULTURE

The smallest models in the range do not employ rapid output size adjustment but benefit from **high-performance tools**, made of different-sized disks, available in various configurations, depending on the application field. The VSE 5 model also benefits from the patented FIT tool system, which are modular and interchangeable tools to make maintenance and replacement of screening elements easier, thanks to interlocking discs with no welding, which means saving up to 75% in maintenance costs.



For mini and midi excavators from 1.5 to 8 tons, the VSE 2, VSE 3 and VSE 5 models are specifically designed for use in the **horticultural field**, for maintenance of **green areas**, for **gardening** and for soil remediation of roots and stones.



INSTANT ADJUSTMENT OF OUTPUT SIZE: SIMEX PATENT

With a **simple control in the cabin**, the Simex designed and patented mechanism allows the shafts to be distanced or closed by means of a hydraulic system. This feature makes it possible to vary the output size of the screened material in only seconds.



The patented system allows distancing and closing the shafts on which the screening tools are fixed, with a maximum travel of 40 mm, to instantly change the particle size of the screened material.

This ensures the operator:

- 1 **speed of execution**
- 2 **considerable time saving**
- 3 **high versatility**

In fact, it is possible to work on different materials, eliminating downtimes due to spacing the shafts or changing tools, as occurs with conventional systems.





**Third phase
discharge of remainder**

>55 mm >2.2 inch



**Second phase - 5 seconds
medium output size ma-
terial**

15-55 mm 0.6-2.2 inch



**First phase - 5 seconds
fine material**

0-15 mm 0-0.6 inch

With a simple control in the cabin, the operator can get **three different particle sizes of the output material with the same bucket**: a fine screening size of 0-15 mm, a medium particle size between 15 and 55 mm, and coarse aggregates greater than 55 mm.*

**Other sizes available on request*

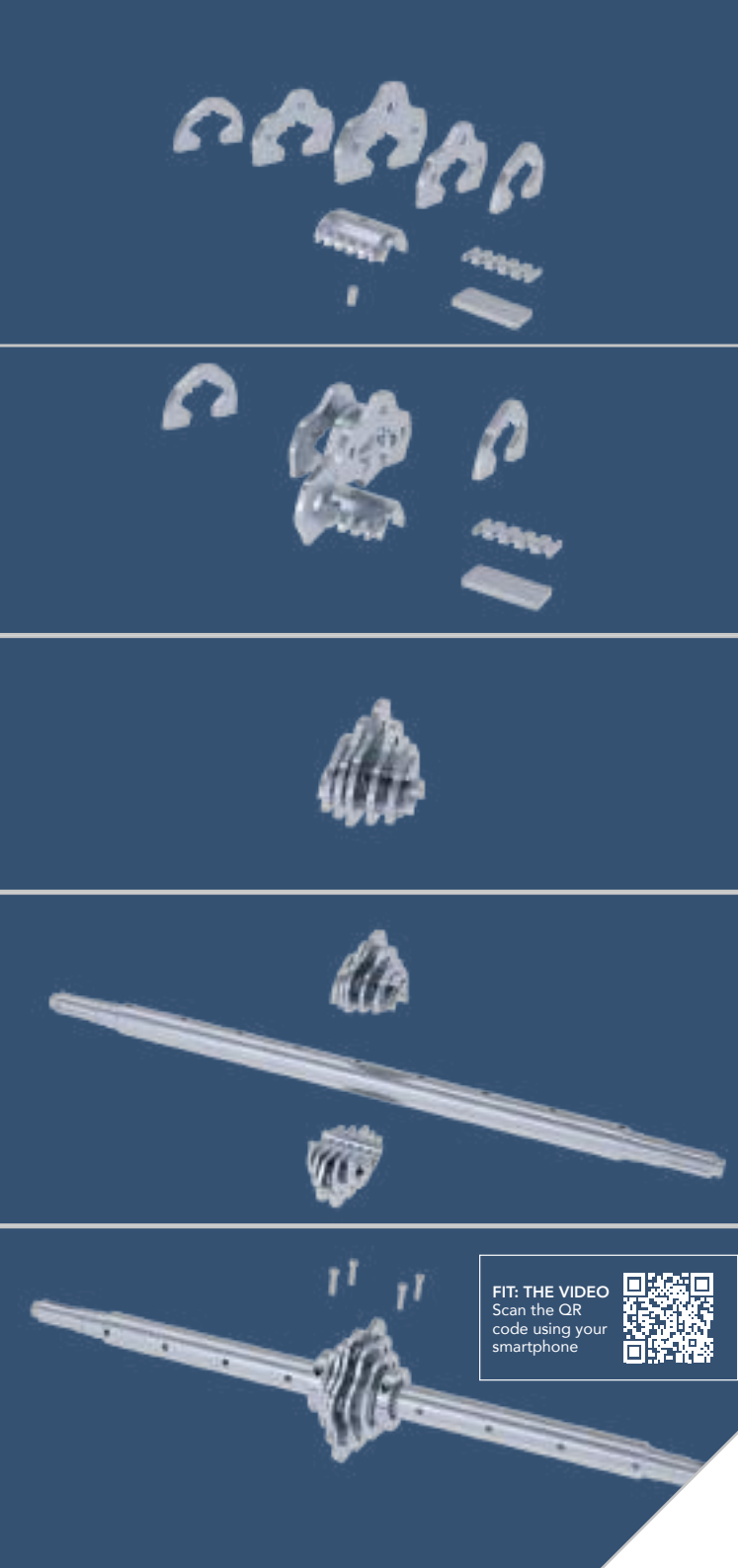

FIT: THE SIMEX-PATENTED TOOL SYSTEM

All models in the VSE range (with the exception of VSE 2 and VSE 3) benefit from the FIT screening tools, Simex patented, which allow the operator to get the best bucket configuration for the intended use and the material to be screened.

1 UP TO 75% LESS IN MAINTENANCE COSTS

The system features independent screening **elements**, which can be **dismantled and replaced individually**. The tools are then fixed to the shaft by means of clamps and two screws, with no welding. All this means saving up to 75% on maintenance costs (compared to the previous system). **Replacement**, in fact, **does not require shaft disassembly**: each element can be replaced individually, in a few minutes, directly on site.

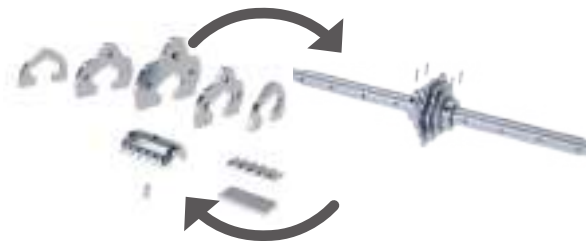

2 HIGH PRODUCTIVITY EVEN WITH HUMID SOILS

Screening shafts are composed of disks of different diameters that interlock perfectly thus producing an intense whirling of the material. **Moist material is easily screened**, without the risk of sticking to the screening tools or the inside walls of the bucket.

3 MULTIPLE CONFIGURATIONS AND REPLACEABLE DISKS

The system allows multiple configurations depending on the materials to be screened. **Simex offers 4 configurations**, but others are possible thanks to the interchangeable disks that make up the screening tool. The new tools are backward compatible with the previous system.

FIT: MAIN CONFIGURATIONS

RECYCLING CONFIGURATION

The recycling configuration is indicated for dry soils, for backfilling excavations and for separating waste demolition material.



DISGREGATION CONFIGURATION

The disgregation configuration, with central blade, provides light crushing of demolition waste or damp or clumped topsoil.



MIXED CONFIGURATION

The mixed configuration is specific for screening topsoil, even humid or wet, for the agricultural, horticultural sector and for the restoration of green areas.



AGGRESSIVE CONFIGURATION

The aggressive configuration was created to handle more compact materials, whether of plant origin, or debris from construction and excavations, where in addition to separation it is necessary to shake off soil adhering to stones, roots, gravel and demolition waste.



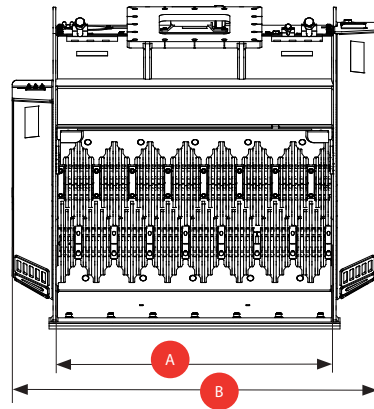
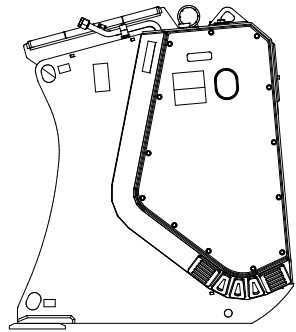

DOWNLOAD THE UPDATED TECHNICAL BROCHURE

Scan the QR code using your smartphone



TECHNICAL DATA		VSE 2	VSE 3	VSE 5	VSE 10	VSE 20	VSE 30	VSE 40	VSE 50
Recommended excavator weight (1) (2)	ton lbs	1.5 - 3 3300 - 6600	3 - 5 6600 - 11000	4 - 8 8800 - 17500	8 - 13 17500 - 29000	12 - 18 26000 - 40000	16 - 30 35000 - 66000	30 - 45 66000 - 99000	35 - 50 77000 - 11000
Mouth width	mm inch	510 20	510 20	620 24	860 34	1100 43	1260 50	1340 53	1420 56
Total width	mm inch	715 28	750 30	900 35	1220 48	1485 58	1650 65	1835 72	1880 74
Bucket capacity (SAE)	m ³ yd ³	0.05 0.06	0.12 0.15	0.20 0.26	0.40 0.52	0.70 0.92	1.00 1.30	1.80 2.35	3.00 3.90
Screening area	m ² yd ²	0.13 0.15	0.19 0.22	0.26 0.31	0.56 0.67	0.80 0.96	1.00 1.20	1.36 1.63	1.36 1.63
Instant adjustment of output size		no	no	no	yes	yes	yes	yes	yes
Shaft travel	mm inch	-	-	-	40 1.6	40 1.6	40 1.6	40 1.6	40 1.6
Number of screening shafts	no.	2	2	2	2	2	2	3	3
Operating weight (3)	kg lbs	105 230	200 440	360 790	965 2125	1400 3080	1845 4060	2725 6000	3500 7715
Required oil flow	l/min gpm	20 - 50 5 - 13	30 - 70 8 - 18	40 - 90 10 - 24	90 - 125 24 - 33	100 - 150 27 - 40	165 - 220 44 - 58	180 - 280 48 - 74	180 - 280 48 - 74
Maximum oil pressure	BAR psi	250 3600	250 3600	250 3600	250 3600	250 3600	250 3600	250 3600	250 3600

(1) The operating load permitted for the excavator, when added to the weight of the standard bucket, must match or exceed the weight of the crusher bucket at full load.

(2) The installer is responsible for ensuring that the equipment meets the excavator's specifications and weight requirement.

(3) Without mounting bracket.

Simex does not accept responsibility or liability for the information provided. Technical modifications may vary without prior notice.

VSU



20 - 45 TON

UNIVERSAL SCREENING BUCKETS

VSU 30 | VSU 40

Designed for separating different-sized materials directly on the work site, Simex VSU screening buckets may be mounted on either excavator boom or front loader via a special frame, and are unique for their easy loading, very simple operation and high productivity.

WATCH THE VIDEO

Scan the QR code using your smartphone



DOUBLE COUPLING

Mounted on either excavator boom or front loader.



Screening elements, in different shapes and sizes, ensure intense whirling of input material.

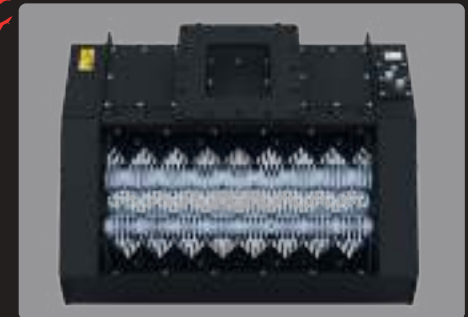

Fitted with FIT, special screening tools that allow for many configurations and low maintenance costs.



SIMEX
• patented •

FIT: THE NEW, PATENTED SCREENING TOOLS

The VSU universal screening buckets are fitted with the patented FIT tool system, which is modular and interchangeable and allows multiple configurations depending on the materials to be screened. Tools are easily and quickly replaced, thanks to interlocking elements with no welding, which means saving up to 75% in maintenance costs.



Simex offers 4 configurations depending on the materials to be screened.

- 1 - The **recycling configuration** is indicated for dry soils, for backfilling excavations and for separating waste demolition material.
- 2 - The **disgregation configuration**, with central grappling hook, provides light crushing of demolition waste or damp or clumped topsoil.
- 3 - The **mixed configuration** is specific for screening topsoil, even humid or wet, for the agricultural and horticultural sector.
- 4 - The **aggressive configuration**, "full-bladed", was created to handle more compact materials, whether of plant origin, or demolition waste debris, where in addition to separation some light crushing is also required.

DOWNLOAD THE UPDATED TECHNICAL BROCHURE

Scan the QR code using your smartphone

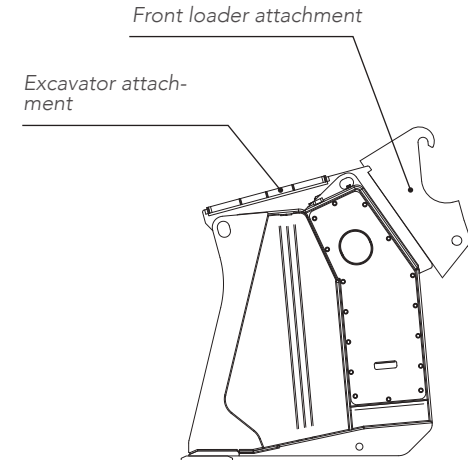

TECHNICAL DATA		VSU 30	VSU 40
Recommended excavator weight	ton lbs	20 - 30 35000 - 66000	30 - 45 66000 - 100000
Mouth width	A mm inch	1700 67	1700 67
Total width	B mm inch	1750 69	1750 69
Bucket capacity (SAE)	m ³ yd ³	1 1.3	1.8 2.85
Screening area	m ² yd ²	0.98 1.17	1.3 1.55
Available sizes *	mm inch	0 ÷ 15, 0 ÷ 45 0 ÷ 0.6, 0 ÷ 1.8	0 ÷ 15, 0 ÷ 45 0 ÷ 0.6, 0 ÷ 1.8
Number of screening shafts	no.	2	3
Operating weight	kg lbs	1735 3825	2750 6050
Required oil flow	l/min gpm	165 - 220 44 - 58	165 - 220 44 - 58
Maximum oil pressure	BAR psi	250 3625	250 3625

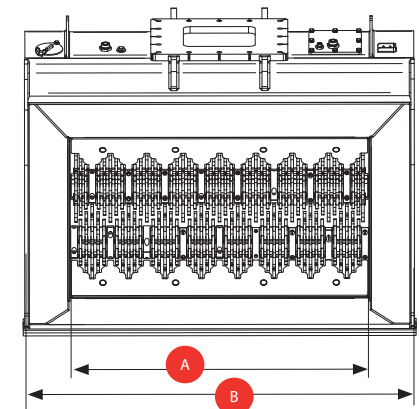

* Fixed-shaft screening bucket: to change size, simply replace tools

Simex does not accept responsibility or liability for the information provided. Technical modifications may vary without prior notice.

WG



3.5 - 20 TON

WALL GRINDERS

WG 40 | WG 50 | WG 60

Designed for excavator boom mounting, Simex WG wall grinders are ideal for smoothing uneven surfaces and removing shotcrete bumps. Low vibration emission makes them optimal for working in sensitive areas, such as city centres, schools, hospitals or tunnels.

WATCH THE VIDEO

Scan the QR code using your smartphone



55° Lateral tilt to right and left.

Piston motor in direct drive with the disk.



Low vibration emission.



SHOTCRETE BUMPS

Shotcrete, guniting, or sprayed cement is cement concrete projected at high velocity onto a surface. It is often used to protect foundation excavations, consolidate embankments and slopes, consolidate damaged walls or to line tunnels. WG wall grinders are specially designed for finishing uneven vertical surfaces or milling shotcrete bumps. The perfect finish and reduced footprint make them ideal for use even in confined spaces such as urban construction sites and tunnels.

DOWNLOAD THE UPDATED TECHNICAL BROCHURE

Scan the QR code using your smartphone



TECHNICAL DATA		WG 40	WG 50	WG 60
Recommended excavator weight (1)	ton lbs	3.5 - 7 7700 - 15400	6 - 12 13000 - 26400	12 - 20 26400 - 44000
Disk diameter	mm inch	400 16	500 20	600 24
Max. power	kW (hp)	22 (30)	34 (46)	50 (67)
Lateral tilt to right and left	-	55°	55°	55°
Speed of rotation	rpm rpm	130 - 160	130 - 160	100 - 130
Operating weight (2)	kg lbs	175 385	290 640	550 1210
Required oil flow	l/min gpm	45 - 70 12 - 18	60 - 110 16 - 29	100 - 180 27 - 47
Maximum oil pressure	BAR psi	300 4350	300 4350	300 4350

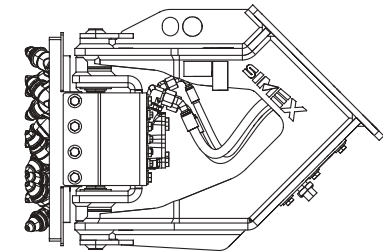
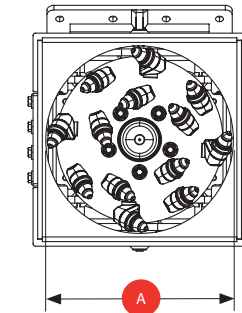

(1) The installer is responsible for ensuring that the equipment meets the excavator's specifications and weight requirement.

(2) Without mounting bracket.

Simex does not accept responsibility or liability for the information provided. Technical modifications may vary without prior notice.



EQUIPMENT FOR

**FRONT LOADERS AND
COMPACT LOADERS**



ART



ASPHALT REPAIR TECHNOLOGY

ART 1000

WATCH THE VIDEO

Scan the QR code using your smartphone



SELF-LEVELLING SYSTEM: CONSTANT PLANING DEPTH, ALWAYS.

Self-levelling to the work surface ensures constant milling depth in any condition, regardless of ground contour or the position of the attachment with respect to the prime mover.

The planer lateral slides automatically align to the milling surface on which they rest to provide maximum stability.

Hydraulic depth adjustment

85 l tank for regeneration additive

Hydraulic side shift

Crusher drum

Milling drum

Ground speed detection wheel

Right and left depth indicator



Simex ART is a patented technology specifically designed for the regeneration of bituminous conglomerate (asphalt) which reuses 100% of the material present on site without removing the milled material or adding other materials.

It is used in functional road surface maintenance, at a depth varying between 30 and 100 mm. It does not disrupt traffic flow and ensures immediate road drivability. It also ensures that maintenance lasts for a reasonable amount of time, which allows local authorities to plan road maintenance, with significant benefits in terms of road user safety.



Alligator cracking, cracks, deterioration.



APPLICATION FIELD

Simex ART is specifically designed for the functional restoration of deteriorated road surfaces, such as:

- branch or alligator cracking
- bumps, dips, ripples
- potholes and gaps
- localized pavement alterations, such as: loss of adhesion and smoothing of the aggregates
- temporary patching



GOALS

Simex ART has a triple goal:

- 1) To repair road surface distress quickly and effectively, without totally disrupting traffic flow and, especially, without repeatedly having to carry out emergency maintenance.
- 2) To reduce the costs of purchasing and handling new mixes by using only the HMA (Hot Mix Asphalt) available on site.
- 3) Environmental sustainability: 100% of the materials present on site are recovered and regenerated, while reducing construction site traffic resulting from procuring new materials and removing waste.



Road is immediately viable after compaction of the conglomerate.



OPERATIONAL ADVANTAGES

- Restoration of road surface distress, quickly and with long-lasting results, which allows for adequate road maintenance planning.
- A dynamic and smaller construction site: no large machines are required, which significantly reduces traffic disruption. A reduced number of workers and a single vehicle containing the necessary equipment.
- Money savings: zero costs for the procurement and transport of new mixes and virgin aggregates.



ENVIRONMENTAL ADVANTAGES

- No impact: pre-existing materials are reused, recycling and rehabilitating worn HMA (Hot Mix Asphalt). Technically, this operation can also be repeated in subsequent maintenance operations.
- Use of eco-friendly materials.
- No handling or management of special materials or waste.



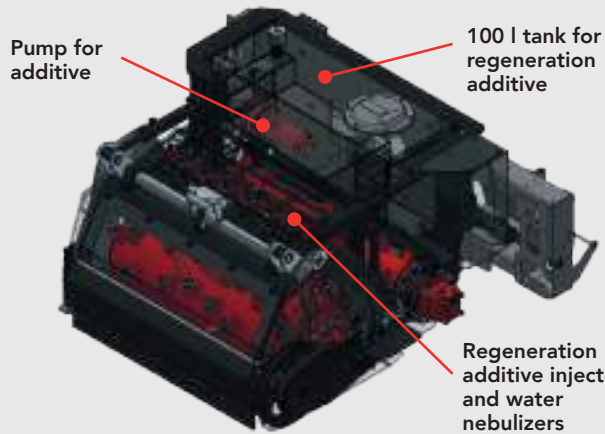

Regeneration additive injectors and water nebulizers

MILLING DRUM: mills and mixes conglomerate with regeneration additive

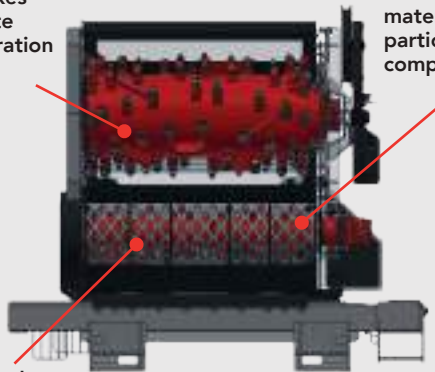

CRUSHER DRUM: reduces milled material to correct particle size and completes mixing

Grille to check material output size

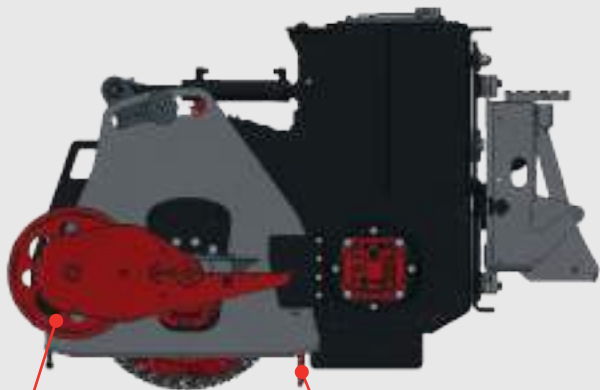

Ground speed detection wheel for correct additive dosing

Bulkhead. Opens or closes access to second chamber containing crusher drum

OPERATION OF ART 1000 AND OPERATING METHODS

1 MILLING AND REGENERATION

Milling (A) from 30 to 100 mm depth (hydraulic adjustment), depending on extent of deterioration. Milled material is mixed with regeneration additive (B) and nebulized (C) at high pressure using special pump. Mixed milled material goes into second chamber where crushing drum (D) reduces to correct particle size and further mixes it. Output grille (E) checks size obtained (0-15 mm).

⚡ Nebulization is checked by a Simex system that ensures maintaining correct additive percentage depending on ground speed detected.

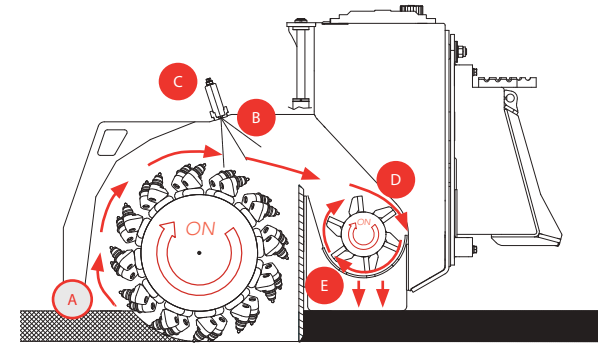

Milling and injection of liquids

Note: it may be necessary to spray water using the integrated nebulization system (depending on type of additive used and conditions and type of asphalt to be resurfaced).

2 MIXING

Mixing (F) milled material obtained using milling drum. The chamber of the crushing drum is closed with special scraper (G). This phase may come after laying possible binder (e.g.: cement). Depending on type of additive used in phase 1).

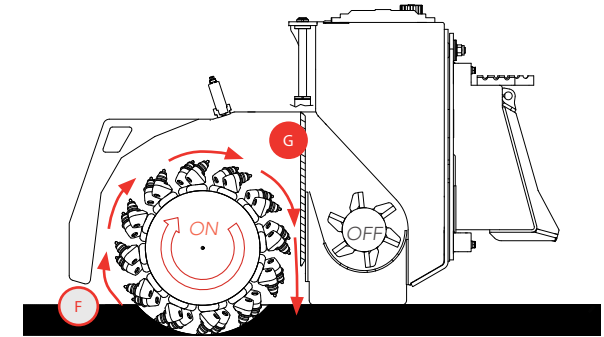

Final mixing

3 COMPACTION

Once regeneration is completed using ART 1000, compaction comes next (plate or roller). The end result is a 100% regenerated bituminous conglomerate which, once compacted, can be driven on immediately.

- A Milling
- D Crusher drum
- G Bulkhead to separate chambers
- B Regeneration additive
- E Grille to check output size 0-15 mm
- C Injectors
- F Final mixing

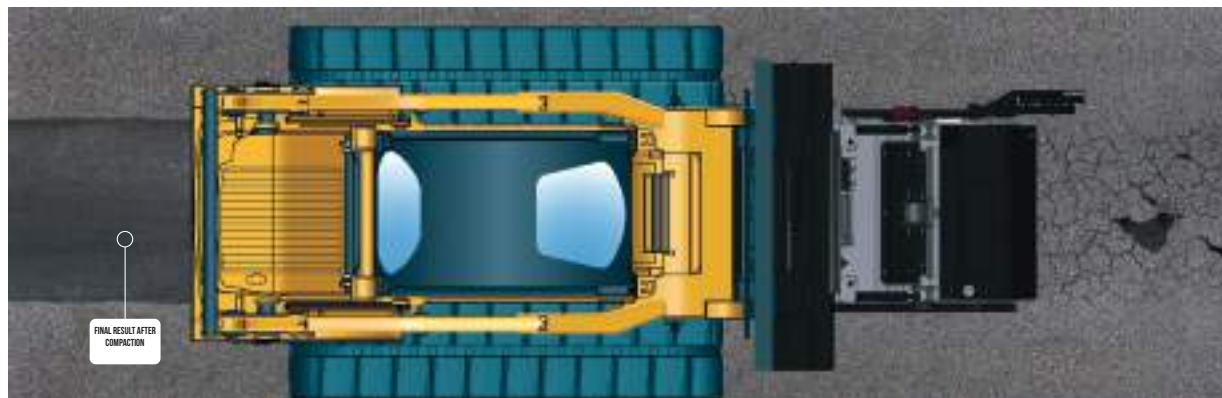



RAP, RECLAIMED ASPHALT PAVEMENT

RAP, or *Reclaimed Asphalt Pavement*, is the term for milled asphalt, classified in national regulations as bituminous conglomerate granulate. In the milling and regeneration phase, Simex ART produces milled material that is later mixed and reduced to the correct size. RAP has the dual advantage of combining reduced construction site costs, tied to the supply of new raw materials, and the possibility of reintroducing the milled material directly on site, within the framework of a circular and sustainable strategy.

DOWNLOAD THE UPDATED TECHNICAL BROCHURE

Scan the QR code using your smartphone



TECHNICAL DATA

ART 1000

MILLING DRUM A		
Width C	mm inch	1000 40
CRUSHER DRUM B		
Width C	mm inch	1000 40
Depth	mm inch	0 - 100 0 - 4
Depth adjustment	independent right and left - hydraulic	
Side shift	hydraulic	
Tilt	12°	
Additive tank capacity	l gal	100 26
Weight (1)	kg lbs	1630 3600
Required oil flow	l/min gpm	115 - 152 30 - 40
Maximum oil pressure	BAR psi	300 4350

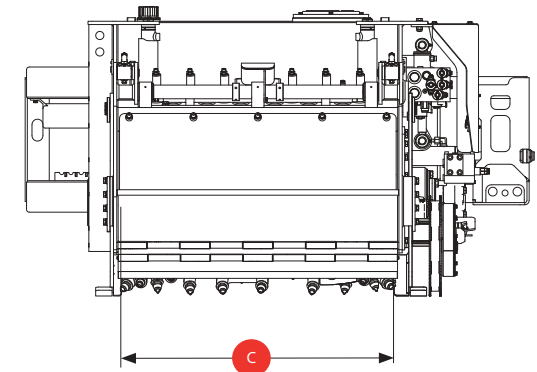
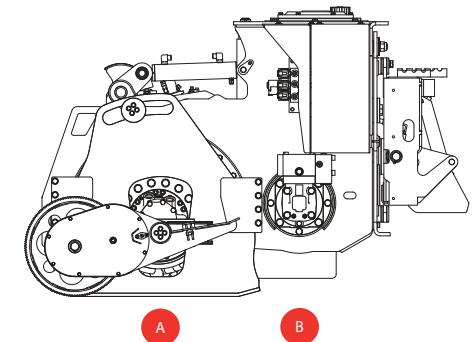

(1) The installer is responsible for ensuring that the equipment meets the prime mover's specifications and weight requirement. Simex does not accept responsibility or liability for the information provided. Technical modifications may vary without prior notice.

BC



BEACH CLEANERS

BC 200

Simex BC Beach Cleaners easily sift wet or dry sand to remove fine debris, small stones and cigarette butts. The debris is easily collected and discharged thanks to the high capacity hopper and hydraulic discharge activated from the cabin. Sifters available with screening grades in: 10x10 mm, 15x15 mm, 20x20 mm.

WATCH THE VIDEO

Scan the QR code using your smartphone



Optical control of working depth

Quick change of sifters.
Standard sifter: 15x15 mm.

Hydraulically-operated sifters

Electro-hydraulic distributor controlled by the operator in the cabin.

Debris hopper: 350 l.

Hydraulic depth adjustment.

SIMEX
• patented •



SIMEX BC FOR BEACH CLEANING

Simex BC is specially designed to free the beach from all that small, hard-to-collect waste including cigarette butts, plastics of all kinds, masks, fishing hooks, rubble, glass fragments and cans.

DOWNLOAD THE UPDATED TECHNICAL BROCHURE

Scan the QR code using your smartphone



TECHNICAL DATA		BC 200
Hopper capacity	l y3	350 0.45
Weight (1)	kg lbs	690 1515
Maximum oil pressure	BAR psi	250 3625
Required oil flow	l/min gpm	70 - 90 18 - 24
Sifting meshes – Screen size (Standard)	mm inch	15x15 0.6x0.6
Sifting meshes – Screen size (Optional)	mm inch	10x10 - 20x20 0.4x0.4 - 0.8x0.8
Working depth	mm inch	0 - 200 0 - 8
Total width A	mm inch	2035 80
Total length B	mm inch	2320 91

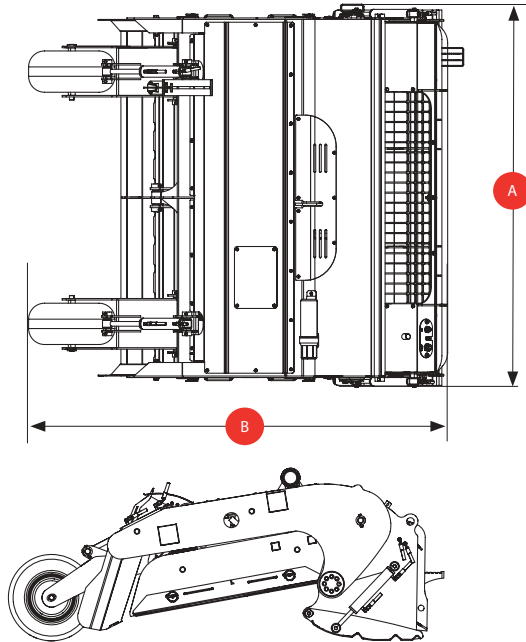

(1) The installer is responsible for ensuring that the equipment meets the prime mover's specifications and weight requirement. Simex does not accept responsibility or liability for the information provided. Technical modifications may vary without prior notice.



CB



CRUSHER BUCKETS

CB 900 | CB 1200 | CB 1500 | CB 2000

The CB crusher buckets for front loading are designed for the volumetric reduction of aggregates directly on site and are ideal for crushing reinforced concrete and demolition materials. The rotor system they are equipped with and the high tooth force generated, allow optimal work with iron, rock, earth and deformable, damp or wet parts. The rotor with teeth is driven by direct-drive, high-displacement radial piston hydraulic motors. An automatic system inverts the rotation of the drum to avoid blockages and machine downtimes.

WATCH THE VIDEO

Scan the QR code using your smartphone



THE TOOLS ENGAGE THE SHAFT without any welding and are easily replaced directly on site.

UPON REQUEST, THEY MAY BE FITTED WITH COUNTER-TEETH OF DIFFERENT SIZES FROM STANDARD to vary the size of the crushed material output.

BREAKABLE MATERIALS: masonry, reinforced concrete, bricks, natural aggregates, concrete, tiles, glass and asphalt slabs.

THE AUTOMATIC DRUM INVERSION SYSTEM ensures continuous work without any downtime.

RADIAL PISTON HYDRAULIC MOTORS, high-displacement, in direct drive with the drum, generate high tooth force. This ensures work is efficient and constant even with rebars inside the reinforced concrete.



FEARLESS AGAINST IRON REBARS

In the treatment of aggregates, reinforced concrete is one of the most difficult materials to crush. The CB buckets, thanks to the rotor system and the high tooth force, **are fearless against the iron rebars** inside demolition waste.



DOWNLOAD THE UPDATED TECHNICAL BROCHURE

Scan the QR code using your smartphone



TECHNICAL DATA		CB 900	CB 1200	CB 1500	CB 2000
Width B	mm inch	1400 55	1500 60	1700 67	1900 75
Bucket capacity (SAE)	m ³ y ³	0.30 0.40	0.45 0.60	0.55 0.70	0.75 1.0
Rotor width A	mm inch	700 27	840 33	965 38	1100 43
Number of teeth	no.	5	6	7	8
Empty operating weight	kg lbs	570 1250	760 1670	950 2090	1150 2530
Operating weight (1)	kg lbs	900 1980	1200 2640	1500 3300	2000 4400
Required oil flow	l/min gpm	40 - 80 11 - 21	70 - 150 18 - 40	70 - 150 18 - 40	70 - 150 18 - 40
Maximum oil pressure	BAR psi	300 4350	350 5075	350 5075	350 5075

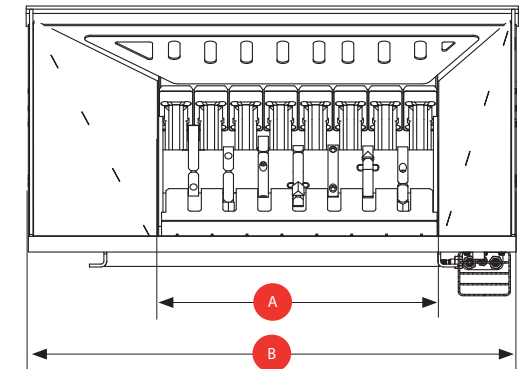
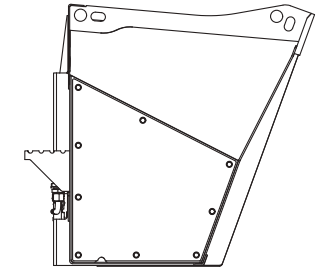

(1) The installer is responsible for ensuring that the equipment meets the prime mover's specifications and weight requirement.

Simex does not accept responsibility or liability for the information provided. Technical modifications may vary without prior notice.



CB 1200. Crushing of demolition waste: bricks and masonry.



CB 1500. Crushing of reinforced concrete in aggregate deposit.



CB 1200. Crushing of aggregates after demolition of private building.



CB 1500. Volumetric reduction of mixed demolition material for reuse on site.

CHD



CHAIN TRENCHERS

CHD 90 | CHD 120 | CHD 150

FOR SKID STEER LOADER

CHD chain trenchers are designed for set-section trenching on natural soils. The discharge screw on the right-hand side and the trench clearing device make sure the trench is kept clean.

WATCH THE VIDEO

Scan the QR code using your smartphone

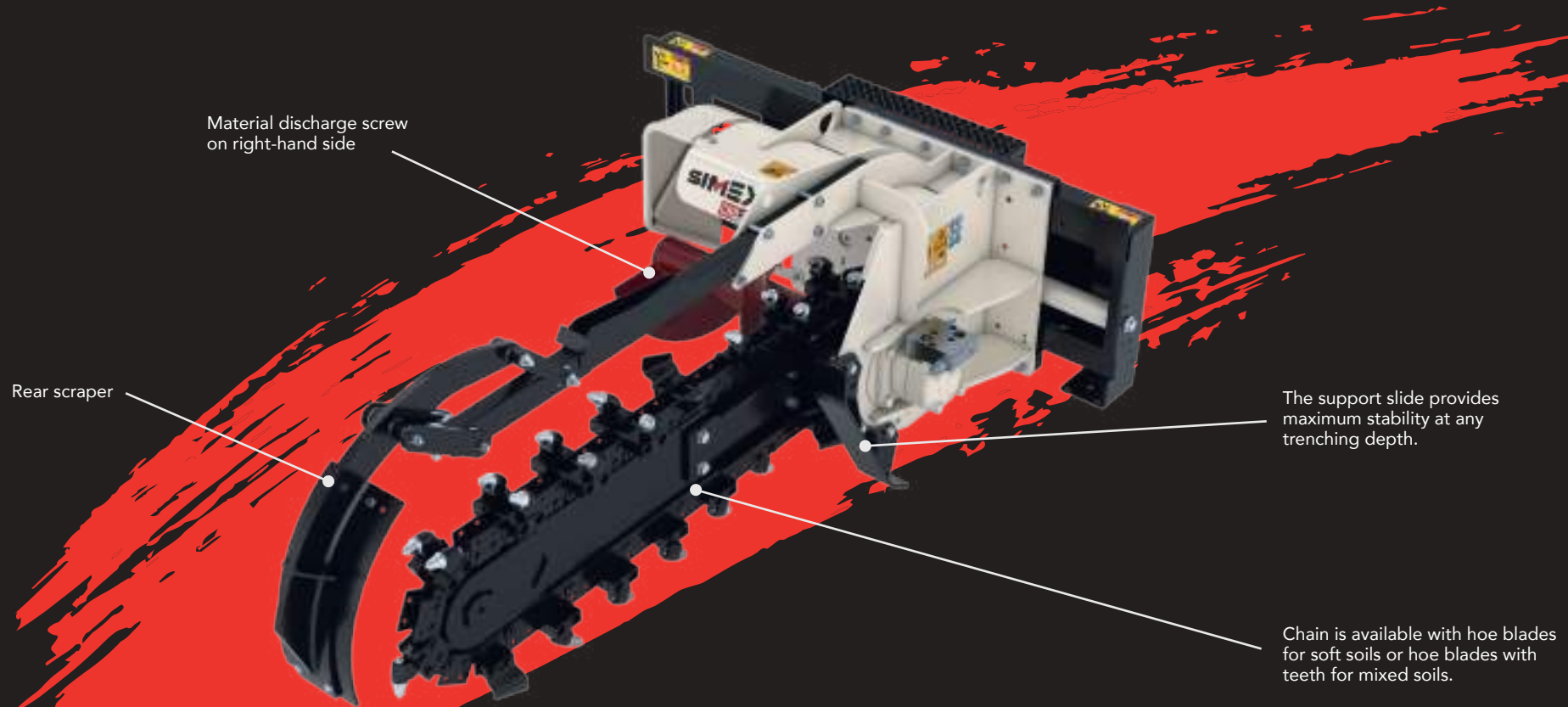

Material discharge screw on right-hand side

Rear scraper

The support slide provides maximum stability at any trenching depth.

Chain is available with hoe blades for soft soils or hoe blades with teeth for mixed soils.

Scan the QR code using your smartphone



			FOR SOFT SOILS		FOR MIXED SOILS		
TECHNICAL DATA			CHD 90S	CHD 120S	CHD 90	CHD 120	CHD 150
Maximum trench depth	A	mm inch	900 35	1200 47	900 35	1200 47	1500 59
Standard trench width		mm inch	150 6	150 6	150 6	150 6	150 6
Optional trench width		mm inch	100 - 200 4 - 8	100 - 200 4 - 8	200 - 250 8 - 10	200 - 250 8 - 10	200 8
Side shift			free		free - hydraulic (optional)		
Scraper			Mechanical with spring		Mechanical with spring		
Operating weight (1)		kg lbs	280 617	425 936	715 1575	780 1715	830 1830
Required oil flow		l/min gmp	35 - 95 9 - 25	60 - 115 16 - 30	60 - 120 16 - 32	70 - 140 18 - 37	90 - 160 24 - 42
Maximum oil pressure		BAR psi	240 3500	240 3500	250 3625	250 3625	250 3625

(1) The installer is responsible for ensuring that the equipment meets the prime mover's specifications and weight requirement. Simex does not accept responsibility or liability for the information provided. Technical modifications may vary without prior notice.

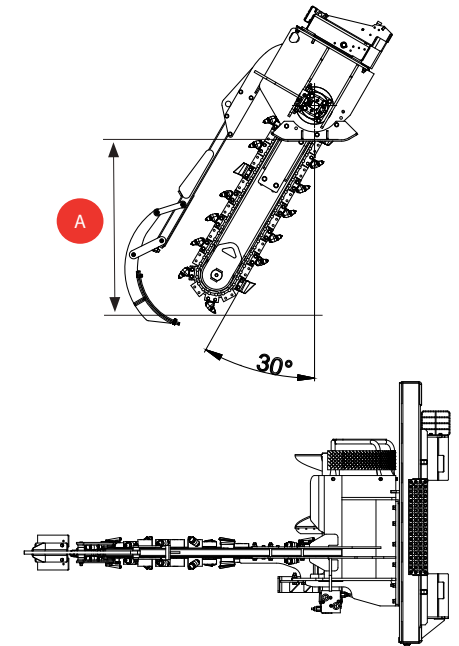

CT



WHEEL COMPACTORS

CT 2.8 BASE | CT 2.8 F.O
CT 3.8 BASE | CT 3.8 F.O

FOR SKID STEER LOADER

Designed for compacting trench bottoms, Simex CT vibrating wheel compactors guarantee a solid, even and well-compacted bottom that ensures maximum road safety and will never give way.

WATCH THE VIDEO

Scan the QR code using your smartphone



Wheel width can be adjusted via bolted sectors that are easily changed on site.

Perfect insulation from prime mover, thanks to the reverse-rotation vibrating twin shaft positioned at centre of the wheel.

Hydraulic depth adjustment

Hydraulic tilt adjustment

Thanks to the hydraulic side shift, it is possible to work completely on machine side.

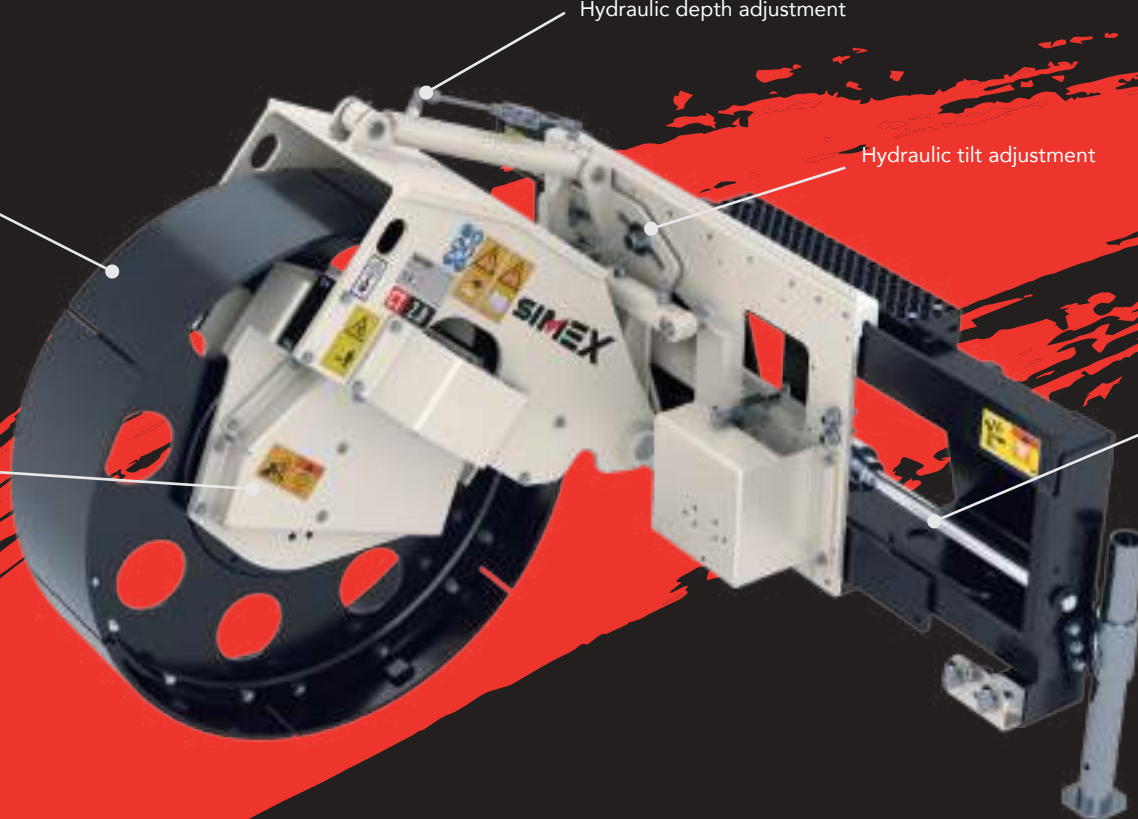



SEGMENTED WHEEL

In order to adapt to various types of section trenching, the CT vibrating compactor base wheel can be adjusted via bolted sectors, easily changed on site. Available widths: 150-200-250-350 and 400 mm.

DOWNLOAD THE UPDATED TECHNICAL BROCHURE

Scan the QR code using your smartphone



TECHNICAL DATA			CT 2.8 BASE	CT 2.8 F.O.	CT 3.8 BASE	CT 3.8 F.O.
BASE WHEEL						
Width of bolted sectors	A	mm inch	150 - 200 - 250 - 350 - 400 6 - 8 - 10 - 12 - 14 - 16	150 - 200 - 250 - 350 - 400 6 - 8 - 10 - 12 - 14 - 16	150 - 200 - 250 - 350 - 400 6 - 8 - 10 - 12 - 14 - 16	150 - 200 - 250 - 350 - 400 6 - 8 - 10 - 12 - 14 - 16
Working depth	B	mm inch	0 - 700 0 - 27	0 - 700 0 - 27	0 - 800 0 - 32	0 - 800 0 - 32
SPECIAL WHEELS						
Wheel widths		mm inch	50 - 75 - 100 2 - 3 - 4	50 - 75 - 100 2 - 3 - 4	50 - 75 - 100 2 - 3 - 4	50 - 75 - 100 2 - 3 - 4
Working depth		mm inch	0 - 350 0 - 14	0 - 350 0 - 14	0 - 450 0 - 17	0 - 450 0 - 17
Vibration frequency		Hz	30 - 40	30 - 40	30 - 40	30 - 40
Hydraulic side shift	C	mm inch	-	1100 43	-	1100 43
Hydraulic transverse tilt			-	18°	-	18°
Max. vertical force		kN lbf	42 9400	42 9400	42 9400	42 9400
Operating weight (1)		kg lbs	720 - 770 1500 - 1700	820 - 970 2020 - 2150	950 - 1100 2090 - 2420	1100 - 1250 2420 - 2750
Required oil flow		l/min gpm	40 - 50 11 - 13	50 - 70 13 - 18	50 - 60 13 - 16	60 - 80 16 - 21
Maximum oil pressure		BAR psi	220 3200	220 3200	220 3200	220 3200

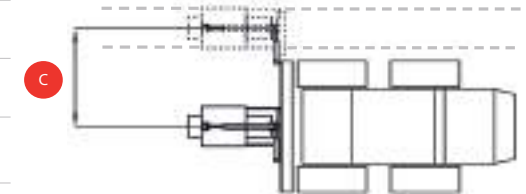
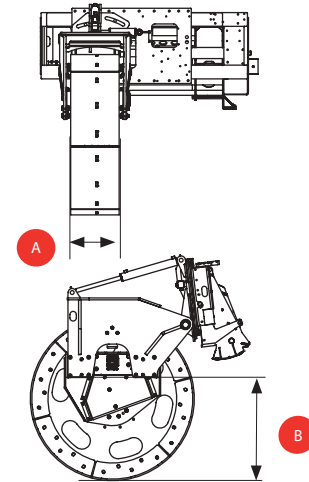

(1) The installer is responsible for ensuring that the equipment meets the prime mover's specifications and weight requirement. Simex does not accept responsibility or liability for the information provided. Technical modifications may vary without prior notice.



CT 2.8 F.O. Non-standard compaction of a set-section trench after laying underground utilities.



PL



SELF-LEVELLING ROAD PLANERS

PL 25.10 | PL 35.15 | PL 40.15 | PL 45.20 | PL 45.20HP | PL 50.20
PL 60.20 | PL 60.20HP | PL 75.20 | PL 1000 | PL 1200 | PL 1200 PL
1500 | PL 2000 | PL 40.35

WATCH THE VIDEO

Scan the QR
code using your
smartphone



PERFORMER

Performer (Simex patented): allows the operator to optimize the equipment's performance according to the forward speed of the operating machine.

INDEPENDENT DEPTH ADJUSTMENT ON THE RIGHT OR LEFT.

Mechanical or hydraulic adjustment (optional). Right and left depth indicator.

Drums in different widths and teeth layout for asphalt or concrete.

MILLED MATERIAL REMAINS IN THE WORK AREA: no accidental launch of material since slides perfectly adhere to work surface.

FLOATING TRANSVERSE TILT WITH DAMPER (Simex patented), alternatively, hydraulic adjustment (optional) with possibility of floating movement.

SPRAY SYSTEM WITH TANK BUILT INTO FRAME

(Simex patented). Includes electro-pump, filter and sprayers (tank also available for positioning on prime mover roof). Controls dust produced during milling operation.

HYDRAULIC SIDE SHIFT (mechanical for PL 25.10, PL 35.15 and PL 40.15). Used in central or lateral position, to the right side, for milling flush to the wall.

SELF-LEVELLING SYSTEM:

CONSTANT PLANING DEPTH, ALWAYS (Simex patented). Self-levelling to the work surface ensures constant milling depth in any condition, regardless of ground contour or the position of the attachment with respect to the prime mover. The planer lateral slides automatically align to the milling surface on which they rest to provide maximum stability.

HYDRAULIC MOTOR IN DIRECT DRIVE WITH THE DRUM

SIMEX
• patented •

The Simex PL self-levelling road planers are designed to remove the entire layer of asphalt or cement in preparation for trenching, or for milling deteriorated sections for later resurfacing. Created to mill pre-set sections on hard and compact surfaces, they allow the possibility to reuse milled material for backfilling trenches.

AVAILABLE DRUMS:



STANDARD DRUMS



CEMENT DRUMS
Reduced pitch compared with standard.



MULTI-TEETH DRUMS
For fine surface milling.



SPECIAL
For widths and/or depths other than standard.



CUTTING DISK



DOUBLE-WIDTH DRUMS
Drums with removable shells (PL 1000 only).

AVAILABLE TEETH:



TEETH FOR ASPHALT



TEETH FOR CEMENT



TEETH FOR MULTI-TEETH DRUMS



PL 60.20: Planing edge of footpath thanks to hydraulic side shift.



PL 45.20: Perfect surfaces with side-by-side passes



PL 45.20 HP: Resurfacing road failure.



PL 60.20: Scarification of concrete flooring in industrial warehouse.



PL 1500. Scarification of running surface in city centre.



PL 1000. Milling flush to wall with hydraulic side shift.



PL 75.20. Mounted on Unimog with special side shift.

SELF-LEVELLING SYSTEM

Self-levelling to the work surface ensures constant milling depth in any condition, regardless of ground contour or the position of the attachment with respect to the prime mover.

learn more on page 74



INDEPENDENT DEPTH ADJUSTMENT

The slides move independently of each other and precisely follow the surface to the right or left. The independent depth adjustment on RH and LH sides combined with the self-levelling system achieves perfectly flat surfaces with side-by-side passes.



FLOATING TRANSVERSE TILT

The floating transverse tilt ensures the drum of the planer is always aligned to the ground, even when prime mover is not parallel to the road surface.



SIDE SHIFT FOR MILLING FLUSH TO WALL

Thanks to the hydraulic side shift, it is possible to work in both central and lateral position, to the right side for milling flush to the wall.



BUILT-IN WATER TANK

The dust suppression system consists of electro-pump, filter, sprayers and water tank built into the side shift (Simex patented). Controls dust produced during milling operation.



MULTI-TEETH DRUM

Multi-teeth drum for surface milling, with millimetric precision thanks to the self-levelling system that maintains constant working depth. Ideal for removal of road surface marking, for creating rumble strips or surface roughness.



PL SCARIFYING MACHINES

The Simex PL range of road planers offers 4 models with oversized drums, specially made for scarification of the running surface of the road: PL 1000, 1200, 1500, 2000, with respective widths: 100, 120, 150 and 200 cm, for working depths of up to 130 mm.



Like other road planers in the range, the PL scarifying machines benefit from Simex-patented solutions, such as: self-levelling system (for always-constant milling depth); independent depth adjustment on the right or left; floating transverse tilt; and the Performer device, which allows the operator to optimize the equipment's performance according to the forward speed of the operating machine.



PL 1000. Precision planing along kerb for resurfacing square.



PL 1500. Scarification with side-by-side passes for repaving port quay.



PL 60.20 on front loader. Removal of entire layer of asphalt in preparation for trenching.





PL 2000. Scarification of running surface, 40 mm depth.



PL 45.20. The independent depth adjustment on RH and LH sides combined with the self-levelling system achieves perfectly flat surfaces with side-by-side passes.



Detail of milling depth during road repair work.

OPTIMIZED MILLING WITH PERFORMER



Mounted in an ergonomic position, easy to view from the operator cabin, the patented **Performer** device optimizes the attachment performance according to the forward speed of the operating machine.

- ➔ **Increases daily productivity**
- ➔ **Significantly reduces machine downtime**
- ➔ **Makes work easier for the operator**

Performer: the video
Scan the QR code using your smartphone to see the PERFORMER in action.



PATENTED SELF-LEVELLING SYSTEM: CONSTANT DEPTH IN ANY CONDITION

The Simex self-levelling system allows maintaining always-constant planing depth in any condition, regardless of ground contour or the position of the attachment with respect to the prime mover. The lateral slides automatically align to the milling surface on which they rest to ensure maximum stability.

The slides move independently of each other and precisely follow the surface to the right or left. **The independent depth adjustment** on RH and LH sides combined with the self-levelling system achieves **perfectly flat surfaces with side-by-side passes.**



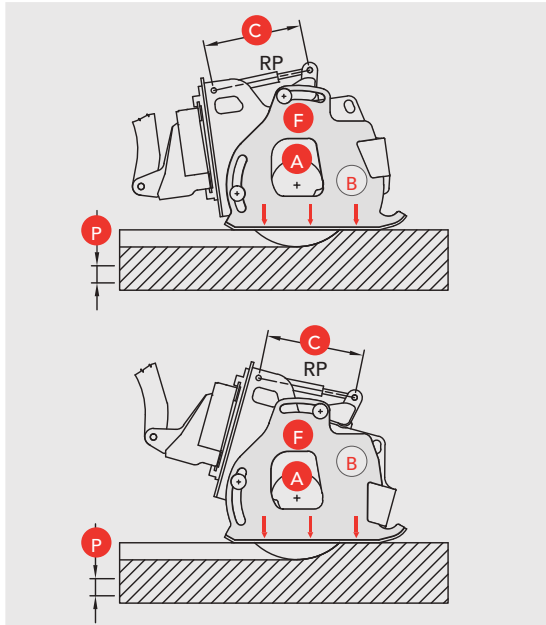

- A** virtual axis
- B** side panel
- C** RP depth adjuster travel
- F** pivot
- P** working depth

The RP depth adjuster (mechanical or hydraulic) moves the pivot up and down (F) to set the working depth (P). If the planer is not horizontal to the ground, the side panel (B) rotates forward or back with respect to the virtual axis (A).

The lateral slides always rest on the ground and the working depth (P) is fixed and constant during advancement. The working depth (P) can be varied only by changing the travel (C) of the depth adjuster RP.

SELF-LEVELLING SYSTEM AND INDEPENDENT DEPTH ADJUSTMENT ON RH AND LH SIDES: BENEFITS



- ➔ Always-constant planing depth
- ➔ Perfect surfaces with side-by-side passes
- ➔ Makes work easier for the operator
- ➔ No accidental launch of material

Self-levelling system: the video
Scan the QR code using your smartphone to see the self-levelling system in action.



PL 2000. Resurfacing deteriorated asphalt after laying fibre optic cables.



PL 1000. Resurfacing industrial yard.



PL 45.20 HP. Removal of deteriorated asphalt layer following road failure.

		STANDARD FLOW PLANERS		HIGH FLOW PLANERS		HIGH POWER PLANERS			HIGH POWER AND HIGH FLOW PLANERS	
TECHNICAL DATA		PL 25.10	PL 35.15	PL 40.15	PL 45.20	PL 45.20 HP	PL 50.20	PL 60.20	PL 60.20 HP	PL 75.20
STANDARD DRUM										
Width	 mm inch	250 10	350 14	400 16	450 18	450 18	500 20	600 24	600 24	750 30
Depth	mm inch	0 - 70 0 - 2.7	0 - 110 0 - 4.3	0 - 150 0 - 5.9	0 - 150 0 - 5.9	0 - 170 0 - 6.7	0 - 170 0 - 6.7	0 - 170 0 - 6.7	0 - 170 0 - 6.7	0 - 170 0 - 6.7
SPECIAL DRUMS										
Maximum depth with reduced width	mm inch	130 5	150 6	170 7	200 8	230 9	230 9	230 9	230 9	230 9
Depth adjustment	independent right and left, mechanical - hydraulic*									
Side shift		mech.	mech./hyd.*	mech./hyd.*	hydraulic	hydraulic	hydraulic	hydraulic	hydraulic	hydraulic
Transverse tilt		-	autom.*	autom.*	autom./hyd.*	autom./hyd.*	autom./hyd.*	autom./hyd.*	autom./hyd.*	autom./hyd.*
Tilt		-	16°	16°	16°	16°	16°	16°	16°	16°
Weight standard version (1)	kg lbs	350 770	590 1300	660 1450	750 1650	860 1900	900 2000	950 2100	1000 2200	1050 2300
Weight version with integrated spray system (1)	kg lbs	-	750 1650	820 1800	910 2000	1020 2150	1060 2330	1110 2440	1160 2550	1210 2660
Required oil flow	l/min gpm	30 - 60 8 - 16	45 - 80 12 - 21	65 - 115 17 - 30	75 - 115 20 - 30	100 - 150 27 - 40	100 - 150 27 - 40	100 - 150 27 - 40	110 - 170 29 - 45	110 - 170 29 - 45
Maximum oil pressure	BAR psi	250 3625	250 3625	250 3625	310 4500	310 4500	310 4500	310 4500	310 4500	310 4500
Dust control spray system	kit for skid steer loader roof with electro-pump or built into side shift with electro-pump									

(1) The installer is responsible for ensuring that the equipment meets the prime mover's specifications and weight requirement.

(*) Upon request (Optional)

Simex does not accept responsibility or liability for the information provided. Technical modifications may vary without prior notice.

Scan the QR code using your smartphone



		SCARIFICATION				HIGH DEPTH
TECHNICAL DATA		PL 1000	PL 1200	PL 1500	PL 2000	PL 40.35
STANDARD DRUM						
Width	A mm inch	1000 40	1200 48	1500 60	2000 80	400 16
Depth	mm inch	0 - 130 0 - 5	0 - 130 0 - 5	0 - 130 0 - 5	0 - 130 0 - 5	100 - 350 4 - 13.7
SPECIAL DRUMS						
Maximum depth with reduced width	mm inch	130 5	130 5	130 5	130 5	350 13.7
Depth adjustment	independent right and left, mechanical - hydraulic*					
Side shift	hydraulic					
Transverse tilt	autom./hyd.*					
Tilt		16°	16°	16°	16°	16°
Weight standard version (1)	kg lbs	1090 2400	1210 2660	1290 2840	1630 3600	1150 2530
Weight version with integrated spray system (1)	kg lbs	1250 2750	1370 3000	1555 3430	1895 4170	-
Required oil flow	l/min gpm	110 - 190 29 - 50	120 - 190 32 - 50	130 - 200 34 - 53	130 - 200 34 - 53	110 - 170 29 - 45
Maximum oil pressure	BAR psi	310 4500	310 4500	310 4500	310 4500	310 4500
Dust control spray system	kit for skid steer loader roof with electro-pump or built into side shift with electro-pump					

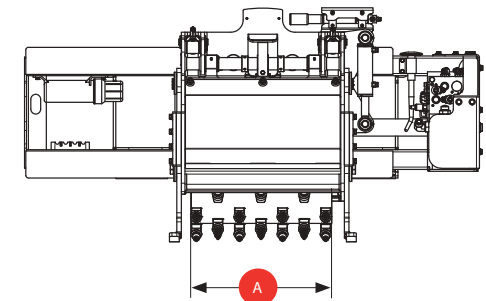
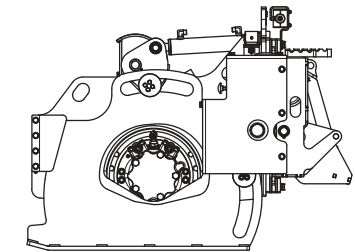

(1) The installer is responsible for ensuring that the equipment meets the prime mover's specifications and weight requirement.

(*) Upon request (Optional)

Simex does not accept responsibility or liability for the information provided. Technical modifications may vary without prior notice.

PL



SSL High Power



Front Loader

SELF-LEVELLING STABILIZERS

PL 60.25 | PL 100.25

Simex PL self-levelling road stabilizers are designed to perform ground stabilization and consolidation. Thanks to the exclusive self-levelling system, milling depth is always constant in any condition. Available with transverse tilt, side shift, independent depth adjustment on the right or left.

WATCH THE VIDEO

Scan the QR code using your smartphone



INDEPENDENT HYDRAULIC RH-LH DEPTH ADJUSTMENT

HYDRAULIC TILT ADJUSTMENT.

WORKING DEPTH UP TO 250 MM.

Excellent for consolidating sub-layers and ideal for mixing material with lime or cement.

PERFORMER

Performer (Simex patented): allows the operator to optimize the equipment's performance according to the forward speed of the operating machine.

SELF-LEVELLING SYSTEM: CONSTANT PLANING DEPTH, ALWAYS (Simex patented). Self-levelling to the work surface ensures constant milling depth in any condition, regardless of ground contour or the position of the attachment with respect to the prime mover. The planer lateral slides automatically align to the milling surface on which they rest to provide maximum stability.

Hydraulic side shift for use in central or lateral position, to the right side.

Hydraulic motor in direct drive with the drum.

MILLED MATERIAL REMAINS IN THE WORK AREA: no accidental launch of material since slides perfectly adhere to work surface.



SIMEX
• patented •



GROUND STABILIZATION

Soil stabilization with lime or cement is a crucial process for improving soil sub-layers before compacting and paving. Stabilization involves using soil already present on site, adding the most suitable binder for soil characteristics, without removing and disposing material. The end result is a substantial improvement on the geotechnical characteristics of the existing soil, increasing its bearing capacity. The soil, mixed with the binder, becomes less sensitive to the action of atmospheric agents.

DOWNLOAD THE UPDATED TECHNICAL BROCHURE

Scan the QR code using your smartphone



TECHNICAL DATA		PL 60.25	PL 100.25
STANDARD DRUMS			
Width	A mm inch	600 24	1000 40
Depth	mm inch	0 - 250 0 - 10	0 - 220 0 - 8.5
SPECIAL DRUMS			
Max. depth	mm inch	-	250 10
Depth adjustment		independent right and left, mechanical/hydraulic (optional)	
Side shift		Hydraulic	
Transverse tilt		Autom./Hydraulic (optional)	
Tilt		16°	16°
Weight standard version (1)	kg lbs	1200 2640	1650 3630
Required oil flow	l/min gpm	110 - 170 29 - 45	120 - 190 32 - 50
Maximum oil pressure	BAR psi	310 4500	310 4500

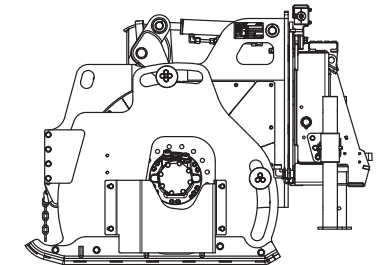
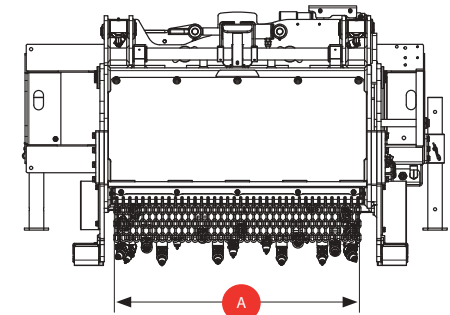

(1) The installer is responsible for ensuring that the equipment meets the prime mover's specifications and weight requirement. Simex does not accept responsibility or liability for the information provided. Technical modifications may vary without prior notice.



PL 100.25. Preparation of substrate for later construction of a concrete yard.



PL 100.25. Mixing and tillage of farmland



PL 100.25. Lime soil stabilization for structural consolidation of road.



PL 100.25. Milled channel after mixing with lime for later compaction.

PL RAIL



PLANERS FOR RAIL TRACKS

PL RAIL

Designed for creating one or two small trenches at sides of rail tracks to be filled later with sound-insulating material. Fitted with two guide wheels positioned at front and rear of milling disks that run on the rail to ensure maximum precision. Wheels available in different shapes and sections for different rail profiles.

WATCH THE VIDEO

Scan the QR code using your smartphone



Hydraulic depth adjustment.

Hydraulic lateral tilt

Hydraulic side shift

Two guide wheels positioned at front and rear of milling disks.

Interchangeable milling disks in different widths and depths, available on request.

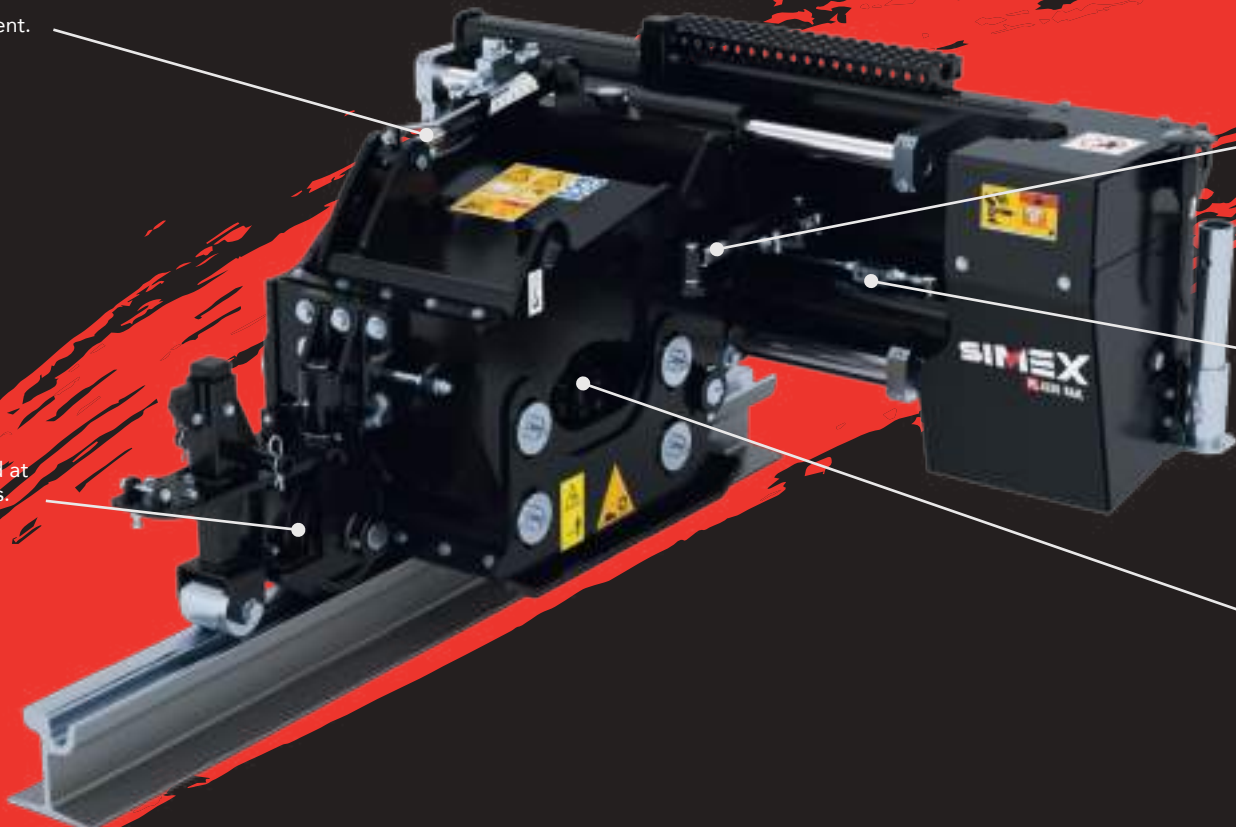

Scan the QR code using your smartphone



TECHNICAL DATA

Disk width	A	mm inch
Depth	B	mm inch
Depth adjustment		
Side shift		
Tilt		
Operating weight (1)		kg lbs
Required oil flow		l/min gpm
Maximum oil pressure		BAR psi

PL RAIL

	30 - 40 - 50 - 60 1.2 - 1.6 - 2 - 2.4
	0 - 70 0 - 2.75
	Hydraulic
	1015 2235
	75 - 115 20 - 30
	310 4500

(1) The installer is responsible for ensuring that the equipment meets the prime mover's specifications and weight requirement.

Simex does not accept responsibility or liability for the information provided. Technical modifications may vary without prior notice.

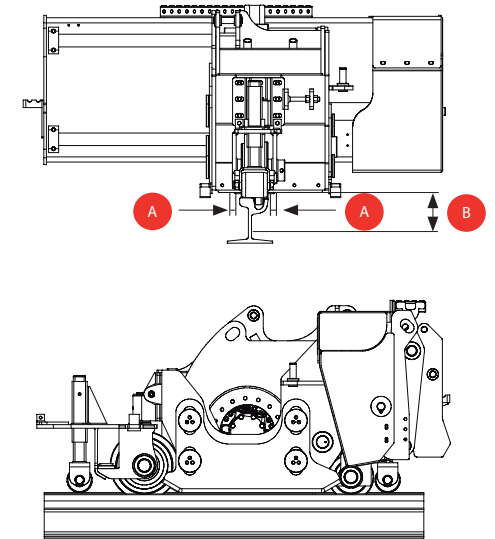

PL SG



ROAD PLANERS FOR MILLING UNDER GUARDRAIL

PL SG

Designed to remove layers of asphalt or cement under the guardrail, the PL SG planer features a slide with support slide, a sliding stop on the upper part, wall side (for resting against guardrail), hydraulic depth adjustment and hydraulic side shift. Option to mount conveyor belt for removing and clearing material milled from trench.

WATCH THE VIDEO

Scan the QR code using your smartphone



Interchangeable milling drums in different widths, available on request.



Hydraulic side shift

Hydraulic depth adjustment

Scan the QR code using your smartphone



TECHNICAL DATA			PL SG
Standard drum width	A	mm inch	350 14
Depth	B	mm inch	0 - 150 0 - 6
Depth adjustment			mechanical / hydraulic optional
Side shift			Hydraulic
Operating weight (1)		kg lbs	715 1570
Operating weight with belt (*) (1)		kg lbs	910 2000
Required oil flow		l/min gpm	75 - 140 18 - 38
Maximum oil pressure		BAR psi	310 4500

(1) The installer is responsible for ensuring that the equipment meets the prime mover's specifications and weight requirement.
 (*) Optional
 Simex does not accept responsibility or liability for the information provided. Technical modifications may vary without prior notice.

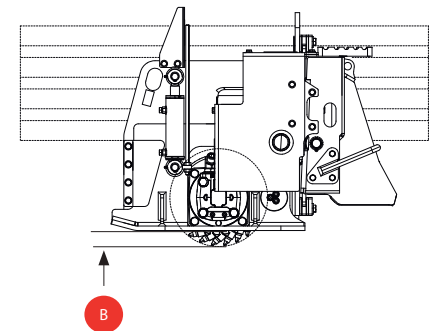
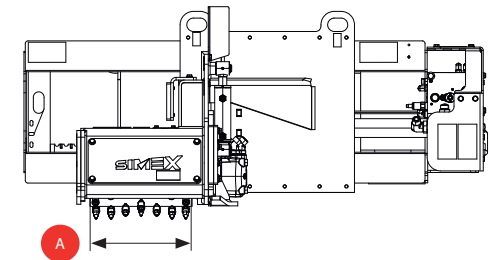

PL SG belt for unloading milled material on side



PLC



ROAD PLANERS WITH CONVEYOR BELT

PLC 18 HP | PLC 24 | PLC 30 | PLC 40

Simex PLC self-levelling planers allows clearing the milled channel and to deposit extracted material on the right or left side. Thanks to the self-levelling system, milling depth is constant in any condition.

WATCH THE VIDEO

Scan the QR code using your smartphone



PERFORMER

Performer (Simex patented): allows the operator to optimize the equipment's performance according to the forward speed of the operating machine.

INDEPENDENT DEPTH ADJUSTMENT on the right or left. Mechanical or hydraulic adjustment (optional).



Automatic tilt adjustment (Simex patented)

HYDRAULIC SIDE SHIFT
Used in central or lateral position, to the right side, for milling flush to the wall.

CONVEYOR BELT with speed adjustment

SELF-LEVELLING SYSTEM: CONSTANT PLANING DEPTH, ALWAYS (Simex patented).
Self-levelling to the work surface ensures constant milling depth in any condition, regardless of ground contour or the position of the attachment with respect to the prime mover. The planer lateral slides automatically align to the milling surface on which they rest to provide maximum stability.

HYDRAULIC MOTOR IN DIRECT DRIVE WITH THE DRUM.

REAR SCRAPER.

SIMEX
• patented •





THE CONVEYOR BELT

The conveyor belt for PLC self-levelling planers becomes an essential asset for optimizing recovery of milled material for reuse on site, for transport or disposal elsewhere. Depending on regulations in force in the country of use, milled asphalt may be immediately reused on site for backfilling trench, or in general as material for road foundations.

DOWNLOAD THE UPDATED TECHNICAL BROCHURE

Scan the QR code using your smartphone



TECHNICAL DATA			PLC 18 HP	PLC 24	PLC 30	PLC 40
Standard drum width	A	mm inch	450 18	600 24	750 30	1000 40
Maximum depth		mm inch	170 7	170 7	170 7	130 5
Depth adjustment			Independent right/left, mechanical - hydraulic Optional			
Side shift			Hydraulic			
Transverse tilt			Automatic			
Tilt			16°			
Operating weight (1)		kg lbs	1020 2245	1100 2400	1200 2650	1360 3000
Required oil flow		l/min gpm	100 - 150 27 - 40	100 - 150 27 - 40	110 - 170 29 - 45	110 - 190 29 - 50
Maximum oil pressure		BAR psi	310 4500	310 4500	310 4500	310 4500

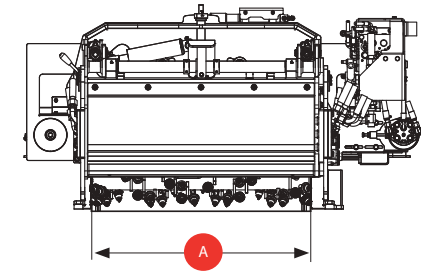
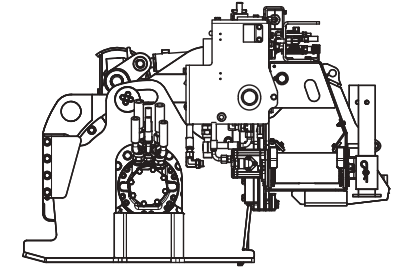

(1) The installer is responsible for ensuring that the equipment meets the prime mover's specifications and weight requirement.

Simex does not accept responsibility or liability for the information provided. Technical modifications may vary without prior notice.



RS



PLANERS FOR RUMBLE STRIPS

RS 16

SIMEX
• patented •

Simex RS planers are designed to create rumble strips, those lines milled into the road surface to produce noise and vibration as a safety measure. Can mill strips in different sizes and/or modify the distance between the strips according to client requirements (or local regulations).

WATCH THE VIDEO

Scan the QR code using your smartphone



Floating transverse tilt

Width, depth and spacing between milled rumble strips may vary upon request.

The oscillating motion is transmitted to the milling unit only; frame is fixed with respect to the prime mover.

Milling drums in different widths, available on request.

Size and spacing of rumble strips are constant and independent from the forward speed.

Hydraulic shift adjustment.



3 TOOLS IN 1

The Simex RS 16 planer combines three applications in one tool: creation of rumble strips, scarification and removal of road surface marking. Like all Simex PL range planers, RS 16 can also be used for scarification of bituminous conglomerate as well as concrete floorings. The attachment can also be used with multi-teeth drum to remove road surface markings—making it a three-for-one application.



TECHNICAL DATA			RS 16 PLANER VERSION FOR RUMBLE STRIPS	RS 16 PLANER VERSION WITH CONTINUOUS CUTTING
Drum width	A	mm inch		300 - 350 - 400 12 - 14 - 16
Depth	D	mm inch		0 - 150 0 - 6
Drum width for fine surface milling (*)		mm inch		350 14
Drum depth for fine surface milling (*)		mm inch		0 - 25 0 - 1
Rumble strip width (1)	C	mm inch	300 - 350 - 400 12 - 14 - 16	
Rumble strip depth (1)	C	mm inch	0 - 25 0 - 1	
Distance between each strip (standard)	B		300 12	
Distance between each strip (optional)	B	mm inch	305 - 610 12 - 24	
Rumble strip length (standard)		mm inch	178 7	
Rumble strip length (optional)		mm inch	150 - 230 6 - 9	
Depth adjustment			-	Manual
Side shift			Hydraulic	Hydraulic
Transverse tilt			Automatic	Automatic
Tilt			16°	16°
Operating weight (2)		kg lbs	1040 2300	830 1830
Operating weight with integrated spray system (2)		kg lbs	1200 2640	990 2200
Required oil flow		l/min gpm	90 - 140 24 - 37	90 - 140 24 - 37
Maximum oil pressure		BAR psi	250 3625	250 3625

DOWNLOAD THE UPDATED TECHNICAL BROCHURE

Scan the QR code using your smartphone

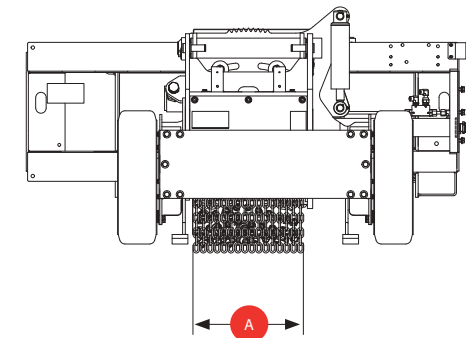
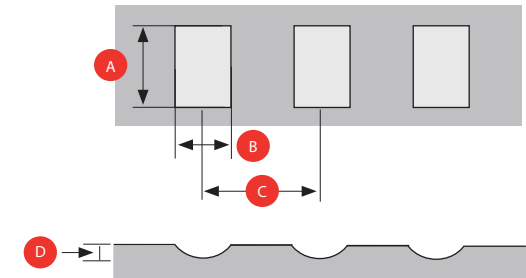

(1) Standard dimensions – different dimensions available on request. (2) The installer is responsible for ensuring that the equipment meets the prime mover's specifications and weight requirement.

(*) Optional

Simex does not accept responsibility or liability for the information provided. Technical modifications may vary without prior notice.



RW RWA



SSL High Flow



SSL High Power



SSL Standard Flow



Front Loader

SELF-LEVELLING WHEEL SAWS

RW 150 | RW 300 | RW 350 | RW 500 | RWA 500 | RWA 700

WATCH THE VIDEO

Scan the QR code using your smartphone



Nebulizer for dust suppression



SEGMENTED WHEEL (only RW/RWA 500 and RWA 700 models).

Disk with removable, interchangeable segments allows quick variation of the trench width while maintaining the same base wheel.

PERFORMER

Performer (Simex patented): allows the operator to optimize the equipment's performance according to the forward speed of the operating machine.

HYDRAULIC LATERAL TILT (only RWA model).

Simex patented, allows cutting disk to be always vertical and perpendicular to ground, even when operating machine is not parallel to the road surface.

SIDE DISCHARGE OF MATERIAL

The special design of outlets allows trench to be cleared efficiently at the depth programmed. Milled material is discharged on both right and left.

SIMEX
• patented •

Designed for skid steer mounting, Simex RW and RWA wheel saws offer a variety of solutions for working on hard or compact surfaces such as asphalt, cement and rock: cutting and narrow trenches, set-section trenches, mini- and micro-trenches for laying fibre optic cables.

THE SELF-LEVELLING SYSTEM

ensures constant trench depth in any condition, regardless of ground contour or the position of the attachment with respect to the prime mover.

AVAILABLE WHEELS:

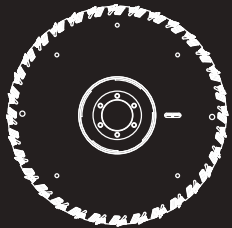

STANDARD WHEEL

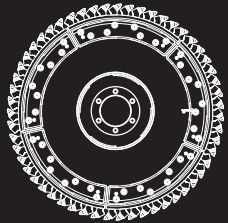

SEGMENTED WHEEL

STANDARD TEETH FOR ASPHALT CEMENT AND ROCK



For wheel widths between 25 and 30 mm



For wheel widths between 40 and 50 mm



For wheel widths 80 mm or greater

OPTIONALS

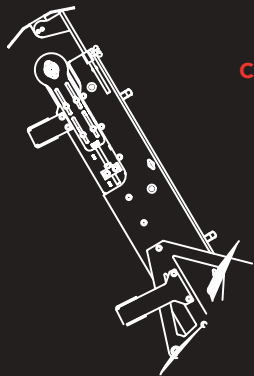

CONVEYOR BELT



ASPIRATION KIT



RW 350. Mini-trench with 30 mm wide wheel.



RWA 500. Wheel saw is always vertical thanks to hydraulic lateral tilt, even when prime mover is not parallel to the road surface.



RW 150 on front loader. Micro-trench at 150 mm depth and 25 mm width.



RW 500. Trench at 500 mm depth for laying fibre optic cables.



RW 350. Mini-trench, 80 mm width.



RW 500 Mini-trench on roadside - 80 mm width and 500 mm depth - for later laying of fibre optic cables.



RW 500 Trench at 120 mm width for laying fibre optic cables.

MINI- AND MICRO-TRENCHING

Unlike with conventional trenching, mini- and micro-trenching are much faster, with much lower production of waste material, considerably lower restoration times and costs. Furthermore, possibility of using smaller operating machines reduces the size of road construction sites benefiting traffic conditions, especially in urban areas.



RW 150, RW 300 AND RW 350: FOR MOUNTING ON SKID STEER LOADERS AND EXCAVATORS

Specifically designed for micro- and mini-trenching for fibre optic cable installation in final connections to buildings, RW 150, RW 300 and RW 350 stand out for their versatility: they are designed for both skid steer and excavator boom mounting (with special mounting bracket). The two attachments ensure cutting and small-section trenches on hard and compact surfaces such as asphalt and cement, for trench widths from 25 to 80 mm and depths from 100 to 350 mm.



HYDRAULIC LATERAL TILT

The RWA 500 and RWA 700 models are fitted with hydraulic lateral tilt, which allows keeping wheel saw always vertical, even when prime mover is not parallel to the road surface, as in the case of trenching near kerbs.

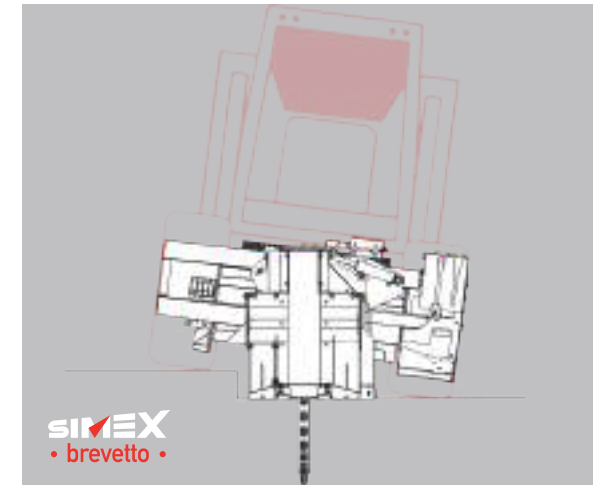

SEGMENTED WHEEL

RW/RWA 500 and RWA 700 models are fitted with segmented wheels. This allows quick variation of the trench width while maintaining the same base wheel. Segments range from a minimum of 50 up to 120 mm width. Assembling and disassembling segments can be done without long machine downtimes or needing the workshop.



Scan the QR code using your smartphone



TECHNICAL DATA			RW 150	RW 300	RW 350	RW 500	RWA 500	RWA 700
Trench width	A	mm inch	25 - 30 - 40 - 50 1 - 1.2 - 1.6 - 2	25 - 30 - 40 - 50 - 80 1 - 1.2 - 1.6 - 2 - 3.2	25 - 30 - 40 - 50 - 80 1 - 1.2 - 1.6 - 2 - 3.2	50 - 80 - 100 - 120 2 - 3.2 - 4 - 5	50 - 80 - 100 - 120 2 - 3.2 - 4 - 5	50 - 80 - 100 - 120 2 - 3.2 - 4 - 5
Trench depth	B	mm inch	100 - 125 - 150 4 - 5 - 6	200 - 250 - 300 8 - 10 - 12	250 - 300 - 350 10 - 12 - 14	250 - 500 10 - 20	250 - 500 10 - 20	450 - 700 18 - 28
Depth adjustment			mechanical	mechanical	mechanical	hydraulic	hydraulic	hydraulic
Side shift			mechanical	hydraulic	hydraulic	hydraulic	hydraulic	hydraulic
Wheel type			standard	standard	standard	segmented	segmented	segmented
Operating weight (1)		kg lbs	225 (2) - 240 (3) 450 (2) - 530 (3)	730 (2) - 790 (3) 1600 (2) - 1740 (3)	940 (2) - 1030 (4) 2070 (2) - 2250 (4)	1275 - 1340 2800 - 2950	1300 - 1400 2860 - 3080	1750 - 1850 3850 - 4070
Required oil flow		l/min gpm	30 - 65 8 - 17	60 - 115 16 - 30	90 - 130 24 - 34	100 - 160 27 - 43	100 - 160 27 - 43	100 - 160 27 - 43
Maximum oil pressure		BAR psi	250 3625	300 4350	300 4350	300 4350	300 4350	300 4350
Lateral tilt			-	-	-	-	●	●
Conveyor belt			-	-	-	□	□	□
Aspiration device			-	-	-	□	□	□

● Standard □ Upon request

(1) The installer is responsible for ensuring that the equipment meets the prime mover's specifications and weight requirement.

(2) With trench wheel width: 25 mm.

(3) With trench wheel width: 50 mm.

(4) With trench wheel width: 80 mm.

Simex does not accept responsibility or liability for the information provided.

Technical modifications may vary without prior notice.

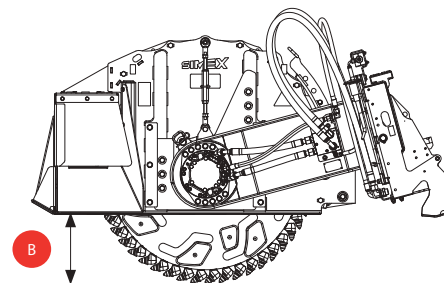
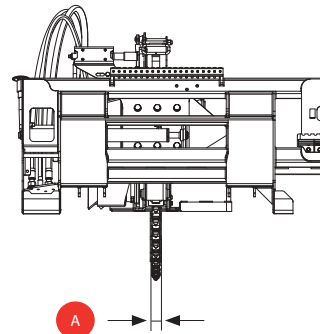

ST



ASPHALT FLOAT

ST 200

ST asphalt floats are designed to lay asphalt or waste material to fill set-section trenches, create footpaths or widen existing roadways. The lateral slides take the existing surface as reference, whereas the thickness of the asphalt spread can be regulated. The floating transverse tilt can be locked in case a slide does not touch the ground.

WATCH THE VIDEO

Scan the QR code using your smartphone

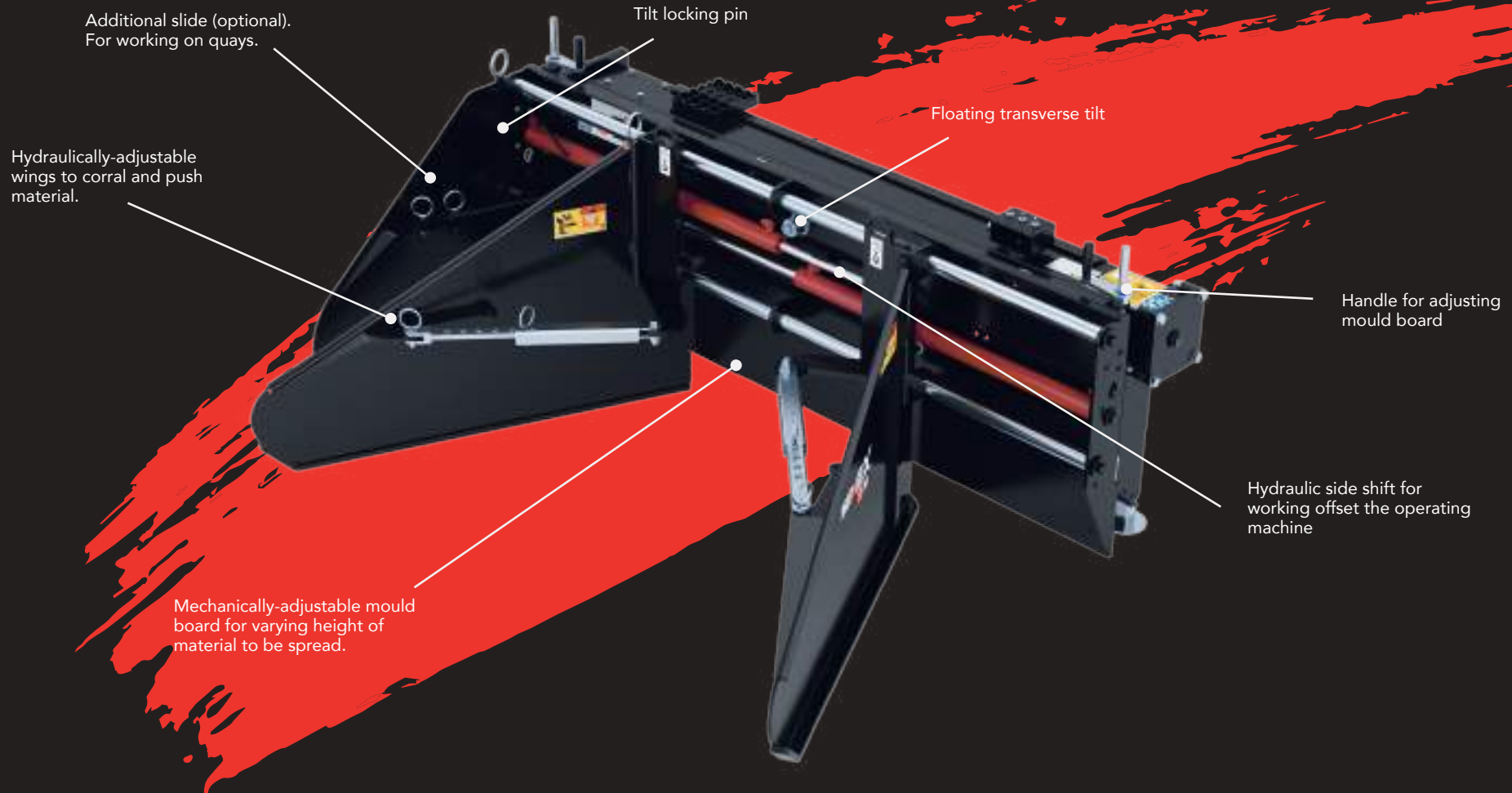



VERSATILITY: OFFSET WORKING POSITION

In road repairs as well as in the final stages of laying underground utilities, using asphalt floats to spread bituminous conglomerate or waste material brings significant benefits in terms of processing times and quality of the final result. Thanks to the hydraulic side shift, the ST 200 asphalt float allows working completely on the side of the machine without having to go over the material just spread.

DOWNLOAD THE UPDATED TECHNICAL BROCHURE

Scan the QR code using your smartphone



TECHNICAL DATA

ST 200

Asphalt laying width regulation		Hydraulic
Asphalt thickness regulation (independent RH-LH)		mechanical
Asphalt thickness	mm inch	0 - 100 0 - 4
Transverse tilt		5°
Tilt locking device		yes
Side shift		hydraulic
Average working speed	m/min feet/min	50 - 120 170 - 400
Operating weight (1)	kg lbs	675 1485
Required oil flow	l/min gpm	45 12
Oil pressure	BAR psi	200 2900

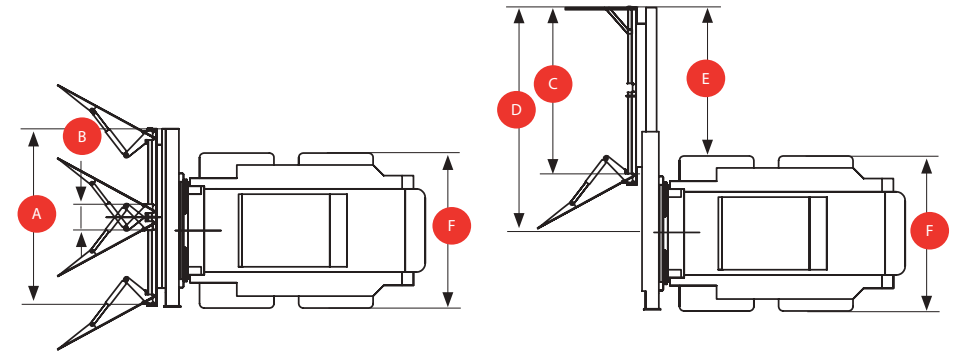

A	mm inch	1900 75
B	mm inch	125 5
C	mm inch	1960 77

D	mm inch	2550 100
E	mm inch	1675 66
F	mm inch	1750 69

(1) The installer is responsible for ensuring that the equipment meets the prime mover's specifications and weight requirement.

(*) Optional

Simex does not accept responsibility or liability for the information provided. Technical modifications may vary without prior notice.



ST 200. Additional external slide allows working on quays.



T TA



SSL High Flow



SSL High Power



Front Loader

WHEEL SAWS

T 200 | T 300 | TA 300 | T 450 | T600 | T 800

WATCH THE VIDEO

Scan the QR code using your smartphone



Nebulizer for reducing dust emission (optional)

SIDE DISCHARGE OF MATERIAL The special design of outlets ensures the correct expulsion of the milled material, leaving the trench cleared at the set depth.

Hydraulic depth adjustment (starting from T 450).

PERFORMER

Performer (Simex patented): allows the operator to optimize the equipment's performance according to the forward speed of the operating machine.

Hydraulic side shift

Cutting disks for widths from 25 to 250 mm, and depths from 150 to 800 mm.

SEGMENTED DISK (Only T450S and T600S models). Disk with removable, interchangeable segments allows quick variation of the trench width while maintaining the same base wheel.

Designed for set-section trenches on hard and compact surfaces such as asphalt, cement and rock, the T and TA wheel saws for skid steer mounting offer cutting and trenching options for depths from 150 to 800 mm, and for widths from 25 to 250 mm.

AVAILABLE WHEELS:

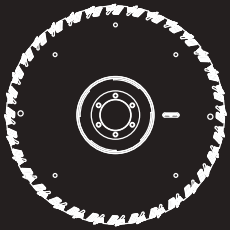

STANDARD WHEEL

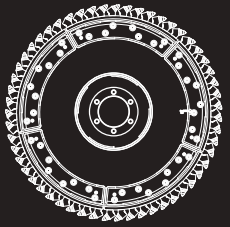

SEGMENTED WHEEL

STANDARD TEETH FOR ASPHALT CEMENT AND ROCK



For wheel widths between 25 and 30 mm



For wheel widths between 40 and 50 mm



For wheel widths 80 mm or greater

OPTIONALS



CONVEYOR BELT



ASPIRATION KIT



T 200 in special configuration.
Micro-trench for laying fibre optic cables.



T 800. Full depth trench (800 mm) for later laying of water pipelines.



TA 300. The hydraulic lateral tilt allows keeping wheel saw always vertical even when prime mover is straddling the footpath.



T 600. Set-section trench for laying underground utilities at 600 mm depth.



T 300. Construction of micro-trench with 25 mm wide disk.



T 450. Set-section trench, 450 mm deep and 160 mm wide.



T 600. Trench excavation in tunnel for later laying of underground utilities.

MINI- AND MICRO-TRENCHING

Unlike with conventional trenching, mini- and micro-trenching are much faster, with much lower production of waste material, considerably lower restoration times and costs. Within the T range, Simex offers models T 200, T 300 and TA 300 for mini- and micro-trenches specifically to install fibre optic cables in final connections to buildings.



HYDRAULIC LATERAL TILT

The TA 300 model is fitted with hydraulic lateral tilt, which allows keeping wheel saw always vertical, even when prime mover is not parallel to the road surface, as in the case of trenching near kerbs.

SIMEX
•patented•

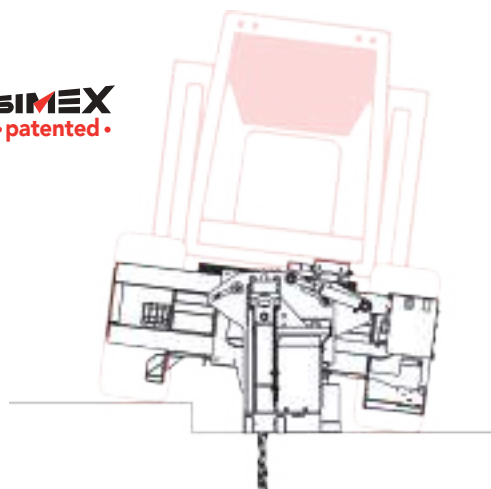

THE T800 MODEL: FOR HIGH HYDRAULIC POWER

The T800 is fitted with a built-in motor that enters the trench, to reach depths of up to 800 mm. This is also the only model that works in reverse.



TRENCH CLEARING DEVICE

The trench clearing device consists of a hydraulically-operated blade that ensures the correct expulsion of material, preparing the trench for laying underground utilities.



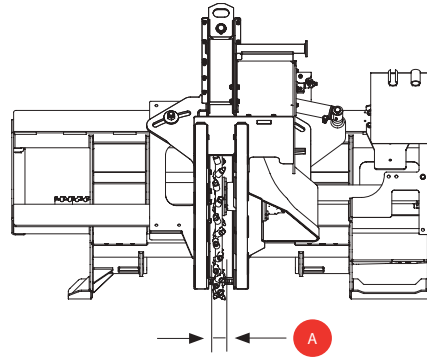
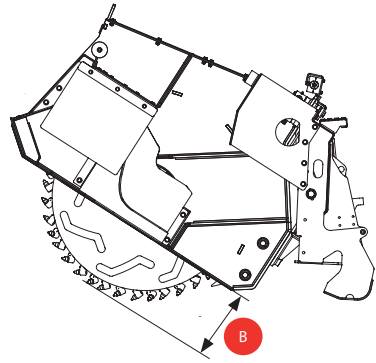

DOWNLOAD THE UPDATED TECHNICAL BROCHURE

Scan the QR code using your smartphone



TECHNICAL DATA			T 200	T 300	TA 300	T 450 (S*)	T 600 (S*)	T 800
Trench width	A	mm inch	25 - 30 - 40 - 50 1 - 1.2 - 1.6 - 2	25 - 30 - 50 - 80 1 - 1.2 - 2 - 3.2	25 - 30 - 50 - 80 1 - 1.2 - 2 - 3.2	50 - 80 - 100 - 130 - 160 - 200 2 - 3.2 - 4 - 5 - 6.3 - 8	80 - 100 - 130 - 160 - 200 3.2 - 4 - 5 - 6.3 - 8	250 10
Trench depth	B	mm inch	200 8	300 12	300 12	150 - 450 6 - 17	200 - 600 8 - 24	450 - 800 17 - 31
Depth adjustments			-	-	-	Hydraulic	Hydraulic	Hydraulic
Side shift			Mechanical	Hydraulic	Hydraulic	Hydraulic	Hydraulic	Hydraulic
Trench clearing device			-	☐	☐	☐	☐	-
Conveyor belt			-	-	☐	☐	-	-
Lateral tilt			-	-	●	-	-	-
Segmented wheel			-	-	-	☐	☐	-
Aspiration device			-	☐	☐	☐	☐	-
Operating weight with standard wheel (1)		kg lbs	270 600	665 1460	845 1860	1115 2450	1340 2950	1430 3150
Required oil flow		l/min gpm	35 - 75 9 - 20	60 - 115 16 - 30	60 - 115 16 - 30	100 - 160 27 - 42	110 - 170 29 - 45	110 - 170 29 - 45
Maximum oil pressure		BAR psi	250 3625	300 4350	300 4350	300 4350	300 4350	300 4350

● Standard ☐ Upon request

1) The installer is responsible for ensuring that the equipment meets the prime mover's specifications and weight requirement.

2) Only for models T450 S and T600 S.

*) Fitted with segmented wheels.

Simex does not accept responsibility or liability for the information provided.
Technical modifications may vary without prior notice.

VS



FRONTAL SCREENING BUCKETS

VS 1500 | VS 2000

Designed for separating different-sized materials directly on the work site, Simex VS frontal screening buckets are unique for their easy loading, very simple operation and high productivity. Specially made for screening waste material from demolitions and trenching, and for the remediation and clearing of soil from stones, roots and other debris.

WATCH THE VIDEO

Scan the QR code using your smartphone



With FIT: the new screening tools.



Screening elements, in different shapes and sizes, ensure intense whirling of input material.



The plate for attaching to the prime mover can be height-adjusted, so cabin can always be opened.

Lightweight, compact structure for easy manoeuvring even in urban construction sites.

SIMEX
• patented •



FIT: THE NEW, PATENTED SCREENING TOOLS

The exclusive, patented FIT tool system allows a variety of configurations depending on the materials to be screened, and ensures up to 75% less in maintenance costs, thanks to interlocking system with no welding. Each tool can be easily replaced directly on site, avoiding long machine downtimes.

DOWNLOAD THE UPDATED TECHNICAL BROCHURE

Scan the QR code using your smartphone



TECHNICAL DATA

			VS 1500	VS 2000
Rotor width	A	mm inch	1160 45	1440 57
Mouth width	B	mm inch	1545 60	1830 71
Bucket capacity (SAE)		m ³ yd ³	0.45 0.59	0.55 0.71
Screening area		m ² yd ²	0.5 0.59	0.6 0.71
Material output size		mm inch	0 - 20* 0 - 0.8*	0 - 20* 0 - 0.8*
Number of screening shafts		no.	2	2
Operating weight (1)		kg lbs	790 1750	920 2020
Required oil flow		l/min gpm	70 - 115 18.5 - 30.3	70 - 115 18.5 - 30.3
Maximum oil pressure		BAR psi	250 3625	250 3625

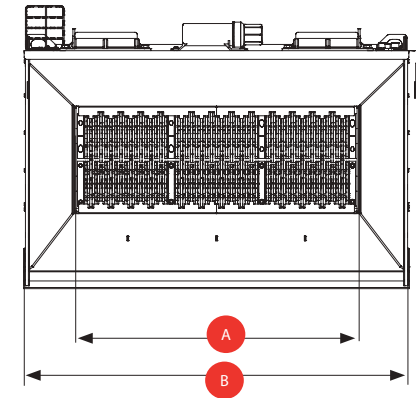
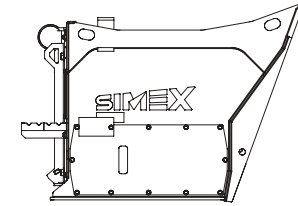

(1) The installer is responsible for ensuring that the equipment meets the prime mover's specifications and weight requirement.

* Other sizes available on request.

Simex does not accept responsibility or liability for the information provided. Technical modifications may vary without prior notice.



simex.it
simex-na.com
simex-buckets.com
simex-drumcutters.com



Simex Srl - Soc. Uninom. - Via Isaac Newton, 31-33
40017 San Giovanni in Persiceto (BO) - ITALY
VAT/P.IVA.00692551203 - F.C./C.F. 04034530370
☎ +39 0516810609 - ✉ simex@simex.it - 📠 +39 0516810628

Simex North America Inc
Registered office: 5 Timmons Ln, Queensbury NY 12804 US
Operational headquarters: 4614 Baldwin Blvd, Corpus Christi TX 78408
☎ +1(361)462-4658 - ✉ info@simex-na.com