

**HENGPU  
(NINGBO) LASER  
TECHNOLOGY  
CO., LTD**



**恒普激光**  
HENGPU LASER

# HENGPU (NINGBO) LASER TECHNOLOGY CO., LTD

恒普（宁波）激光科技  
有限公司



恒普激光  
HENGPU LASER

Metal / Ceramic 3D  
Printing Expert

HENGPU  
(NINGBO) LASER  
TECHNOLOGY  
CO., LTD

恒普（宁波）激光  
科技有限公司

地址：浙江省宁波市高新区木槿路 96 号

Add: No. 96, Hibiscus Road, High tech Zone, Ningbo, Zhejiang

E-mail: [Liudgmse@163.com](mailto:Liudgmse@163.com) | 网址 (web): [www.hengpulaser.com](http://www.hengpulaser.com)

销售热线 Hotline/Telephone: +86-133 1468 6611

联系人 Contact Person: Manager, Mr Liu 刘经理



# CONTENTS

## 目录

<b>1</b>	<b>ABOUT HENGPU LASER</b> 关于恒普激光	02-03
<b>2</b>	<b>MILLING MACHINE SERIES</b> 铣刨机系列	04-07
<b>3</b>	<b>COAL PICK SERIES</b> 煤截齿系列	08-15
<b>4</b>	<b>ROADHEADER SERIES</b> 掘进机系列	16-17
<b>5</b>	<b>ROTARY EXCAVATION SERIES</b> 旋挖系列	18-21
<b>6</b>	<b>MILLING EXCAVATOR SERIES</b> 铣挖机系列	22-23

# ABOUT HENGPU LASER

## 关于恒普激光

恒普激光是由留美博士团队于 2013 年成立的高新技术公司，公司致力于工业激光 3D 打印的技术推广与产业化，是我国民用 3D 打印领域的领导者和开拓者，在大型零件 3D 打印、特种陶瓷 3D 打印领域处于国际领先水平。

公司推出的“FREEFORM”陶瓷 3D 打印技术、“SUPERHARD”技术、“SUPERWEAR”技术，突破了刀具传统制造技术的瓶颈问题，旗下 3D 打印品牌“恒普截齿”已成为工程刀具领域的领导品牌，已成功在矿山开采、地铁隧道、石油勘探、路桥基建四大领域开发出 30 余款产品，打破了国际刀具巨头在我国工程刀具领域的垄断。

恒普激光为国家高新企业，公司通过质量管理体系认证 (ISO9001:2008) 和军工产品质量管理体系认证 (GJB9004B-2009)，旗下分别设有恒普（宁波）激光科技有限公司和哈尔滨恒普激光应用技术有限公司。

公司掌握多项核心技术，申请及授权发明专利十余项，公司先后获得全球新材料行业大赛一等奖、全国创新创业大赛优秀奖、胡润百富榜中国最具投资价值新星黑龙江 10 强等多项荣誉。成立以来先后获得元禾原点、富德创投、丁香汇等著名投资机构多轮投资。

2019 年，作为宁波市 27 个重点引进项目，恒普激光落户宁波国家高新区，公司创始团队成功入选宁波市“3315 计划”、“高新精英计划”等海外高层次人才引进项目，成为宁波市高新区重点培育的高科技型企业。

恒普激光秉承着科技创新的理念，致力于将先进技术应用于工业领域，努力打造令人尊敬的民族品牌，为产业报国奉献一份绵薄之力。



HENGPU (NINGBO)  
LASER TECHNOLOGY  
CO., LTD

金属 / 陶瓷 3D 打印专家

# METAL / CERAMIC 3D PRINTING EXPERT

Hengpu Laser is a High-tech company founded in 2013 by the Doctor team studied in the United States. The company is committed to the technology promotion and industrialization of industrial laser 3D printing. It is the leader and pioneer in the field of civil 3D printing in China, and is in the international leading level in the field of 3D printing of large parts and special ceramics.

With the "FREEFORM" ceramic 3d printing technology,"SUPERHARD" and "SUPERWEAR" technologies developed by our company, we have broken through the bottleneck of conventional tool manufacturing. Our 3D printing brand "Hengpu pick" has become a leading brand in the field of engineering tools. We have successfully developed more than 30 products in the fields of mining, subway tunnel, oil exploration and road & bridge infrastructure, breaking the monopoly of international tool tycoons in the field of engineering tools in China.

Hengpu laser is the (Chinese) national High-tech enterprise, and have gotten the quality management system certification (ISO9001:2008) and military product quality management system certification (GJB9004B-2009) There are two subsidiaries, namely Hengpu (Ningbo) Laser Technology Co., Ltd and Harbin Hengpu Laser Application Technology Co., Ltd.

Our company has mastered a number of core technologies, and is authorized more than 10 invention patents, We has won the first prize in the Global New Materials Industry Competition, the National Innovation and

Entrepreneurship Competition excellence award, Hurun Rich List of China's most investment value nova Heilongjiang Top 10 and other Honours. Since the establishment, We have obtained several rounds of investment from famous investment institutions such as Orize Holdings, FD Ventures and Lilac Ventures.

Hengpu Laser adheres to the concept of scientific and technological innovation, We devotes ourselves to applying advanced technology to the industrial field, building a respectable national brand, and making our contributions in serving the country.



# MORE THAN 10 TIMES HIGHER IN WEAR RESISTANCE

The 3D printing of more than ten kinds of ceramics (e.g.,  $Al_2O_3$ ,  $ZrO_2$ , SiC, WC, CBN, etc.) has been realized.

实现了十余种  
陶瓷3D打印( $Al_2O_3$   $ZrO_2$  SiC  
WC CBN等陶瓷)

耐磨性比金属提高  
10倍以上



应用领域：地铁、隧道、  
基建施工，石油、煤、天然气、  
矿山开采

**Application:** Construction of subway, tunnel and other infrastructures; extraction of oil, coal, natural gas and mines.

## PAVEMENT



# MILLING MACHINE SERIES

## 铣刨机系列

Put forward the New concept of structural and functional integration. Transformation of military technology to civilian use, new breakthrough in the field of tool manufacturing.

提出结构功能一体化新概念，军工技术转民用，刀具制造领域新突破：

新概念、新技术、新产品

NEW CONCEPTS

NEW TECHNOLOGIES

NEW PRODUCTS



世界最先进的粗晶碳化钨合金，微观时效弥散强化设计，比传统合金寿命大幅提高。

The world's most advanced coarse-grained tungsten carbide alloy, micro-aging dispersion strengthening design, and significantly improved service life compared to conventional alloys.

恒普 "FREEFORM" 3D 打印技术，超级耐磨材料，增加合金寿命。恒普三维仿生结构 "3D-B&F" 技术，自适应旋转功能，防止偏磨。

Hengpu's "FREEFORM" 3D printing technology, together with the super wear-resistant materials greatly prolong the alloy life. Hengpu adopted bionic structure "3D-B&F" technology with the self-adaption function to prevent eccentric wear.

军工级高纯度基体材料，额外增加“调质”特殊热处理工艺，具有优异的高硬度与高韧性综合性能，耐磨不易断。

Military grade high purity matrix material, with additional "quenching and tempering" special heat treatment process, has excellent comprehensive properties of high hardness and high toughness, High resistance to wear and fracture.

HP20T2

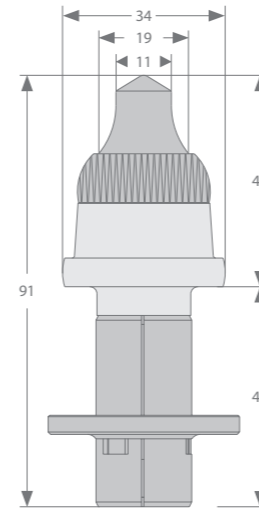

HP20T2D

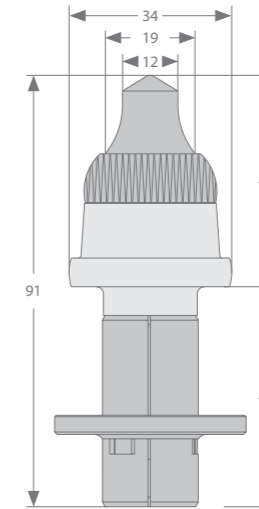

HP20T2S

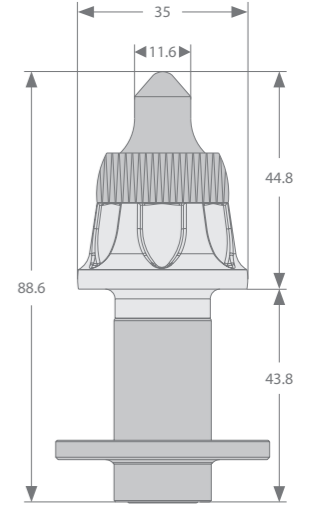

HP22T2

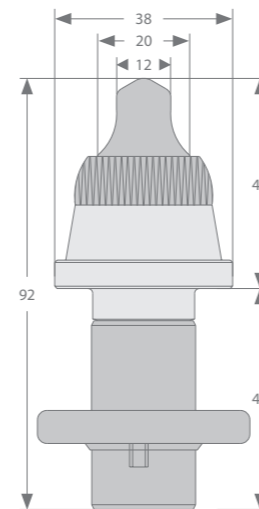

HPSN20-13D

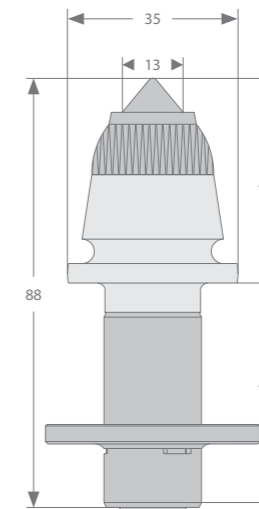

HPSN22-13D

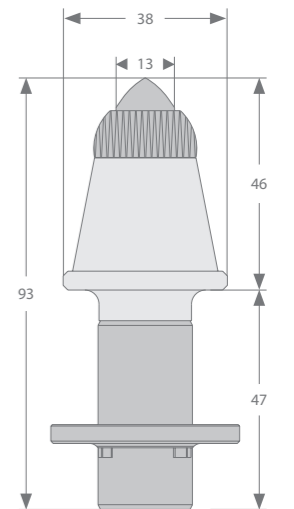

型号 Model	包装方式 Packaging Method	包装件数 Number of Packages	重量 / 箱 Weight/Box	整托箱数 Whole Pallet Box	整托重量 Whole Pallet Weight
HP20T2	箱 Box	50	16.63KG	60 箱 / 60 Box	997.8KG
HP20T2D	箱 Box	50	16.63KG	60 箱 / 60 Box	997.8KG
HP20T2S	箱 Box	50	15.8KG	60 箱 / 60 Box	948KG
HPSN20-13D	箱 Box	50	15.9KG	60 箱 / 60 Box	954KG
HP22T2	箱 Box	40	16.3KG	60 箱 / 60 Box	978KG
HPSN22-13D	箱 Box	50	15.9KG	60 箱 / 60 Box	954KG

# MORE THAN 10 TIMES HIGHER IN WEAR RESISTANCE

The 3D printing of more than ten kinds of ceramics (e.g.,  $\text{Al}_2\text{O}_3$ ,  $\text{ZrO}_2$ , SiC, WC, CBN, etc.) has been realized.

实现了十余种  
陶瓷3D打印( $\text{Al}_2\text{O}_3$   $\text{ZrO}_2$  SiC  
WC CBN等陶瓷)

耐磨性比金属提高  
10倍以上



应用领域：地铁、隧道、  
基建施工，石油、煤、天然气、  
矿山开采

**Application:** Construction of subway, tunnel and other infrastructures; extraction of oil, coal, natural gas and mines.

## COAL MINING



# COAL PICK SERIES

## 煤截齿系列

Overcome technological barrier of ultrafast solidification in 3d printing, which leads to higher crystal growth rate and finer internal structure without defects.

攻克了 3D 打印超快凝固技术，晶体生长更迅速，内部组织更细密，无缺陷。

新技术、新工艺、新产品

世界最先进的粗晶碳化钨合金，微观时效弥散强化设计，比传统合金寿命大幅提高。

The world's most advanced coarse-grained tungsten carbide alloy, micro-aging dispersion strengthening design, and significantly improved service life compared to conventional alloys.

恒普 "FREEFORM" 3D 打印技术，超级耐磨材料，增加合金寿命。恒普三维仿生结构 "3D-B&F" 技术，自适应旋转功能，防止偏磨。

Hengpu's "FREEFORM" 3D printing technology, together with the super wear-resistant materials greatly prolong the alloy life. Hengpu adopted bionic structure "3D-B&F" technology with the self-adaption function to prevent eccentric wear.

军工级高纯度基体材料，额外增加“调质”特殊热处理工艺，具有优异的高硬度与高韧性综合性能，耐磨不易断。

Military grade high purity matrix material, with additional "quenching and tempering" special heat treatment process, has excellent comprehensive properties of high hardness and high toughness, High resistance to wear and fracture.

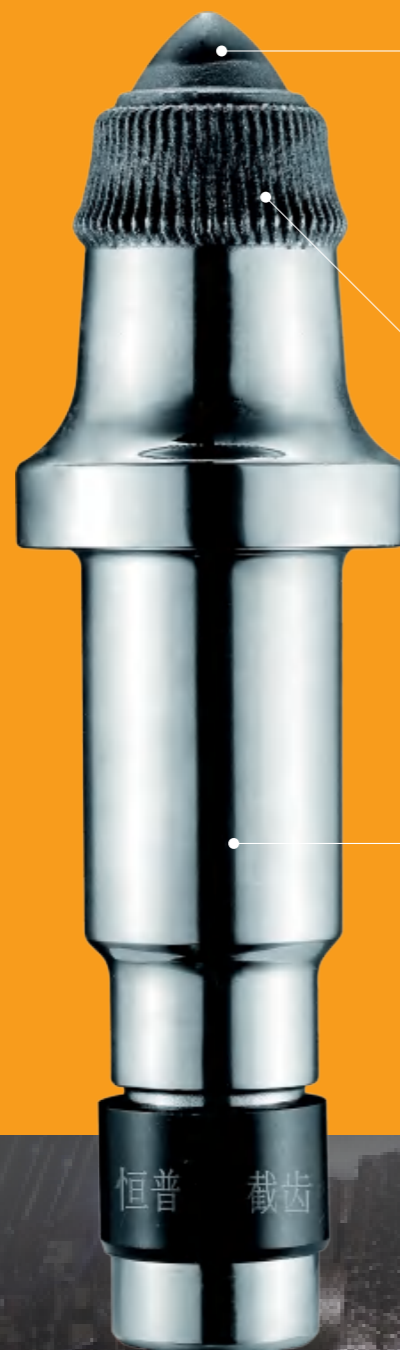

NEW TECHNOLOGIES

NEW PROCESSES

NEW PRODUCTS

HPU47-19TD

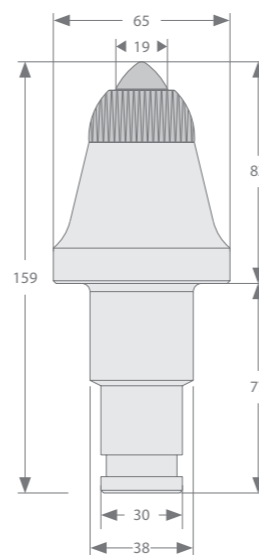

HPU47-22TD

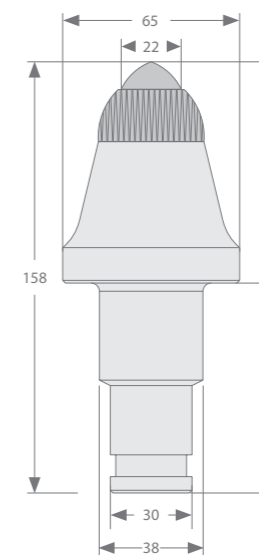

HPU47-25TD

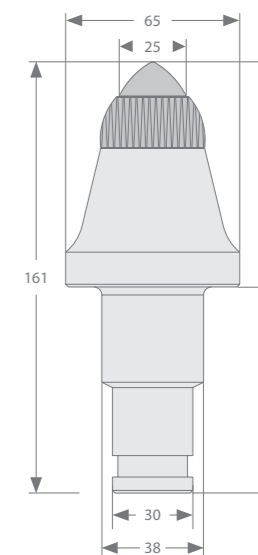

HPU82-17TD

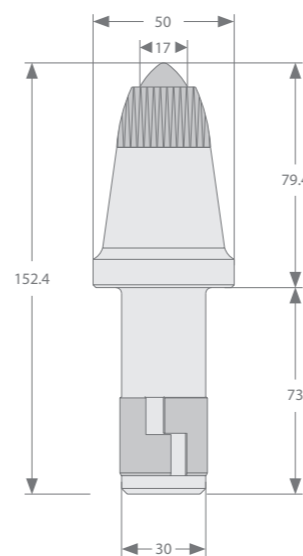

HPU82-19TD

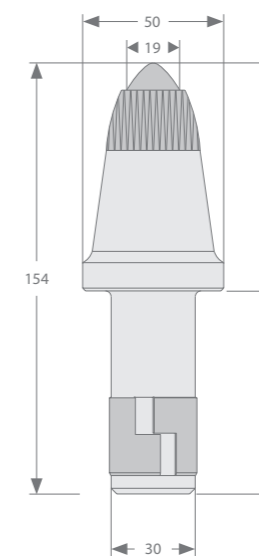

HPU82-19TD  
加长

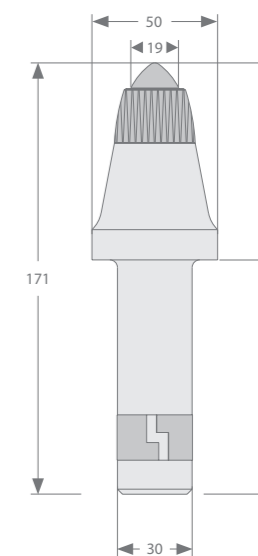

型号 Model	包装方式 Packaging Method	包装件数 Number of Packages	重量 / 箱 Weight/Box	整托箱数 Whole Pallet Box	整托重量 Whole Pallet Weight
HPU47-19TD	箱 Box	10	16KG	60 箱 / 60 Box	960KG
HPU47-22TD	箱 Box	10	16.7KG	60 箱 / 60 Box	1002KG
HPU47-25TD	箱 Box	10	19KG	60 箱 / 60 Box	1140KG
HPU82-17TD	箱 Box	20	21KG	60 箱 / 60 Box	1260KG
HPU82-19TD	箱 Box	20	21KG	60 箱 / 60 Box	1260KG
HPU82-19TD(lengthen加长)	箱 Box	20	22.4KG	60 箱 / 60 Box	1344KG



# COAL PICK SERIES

## 煤截齿系列

Make Breakthrough in the control process of high-temperature active 3d melt compositions and achieve an ultra-purified metallurgical control, which leads to a high material purity.

突破了高温活性三维熔体成分控制工艺，实现超纯净冶金控制，材料更纯净。

新工艺、高纯度、高性能



世界最先进的粗晶碳化钨合金，微观时效弥散强化设计，比传统合金寿命大幅提高。

The world's most advanced coarse-grained tungsten carbide alloy, micro-aging dispersion strengthening design, and significantly improved service life compared to conventional alloys.

恒普 "FREEFORM" 3D 打印技术，超级耐磨材料，增加合金寿命。恒普三维仿生结构 "3D-B&F" 技术，自适应旋转功能，防止偏磨。

Hengpu's "FREEFORM" 3D printing technology, together with the super wear-resistant materials greatly prolong the alloy life. Hengpu adopted bionic structure "3D-B&F" technology with the self-adaption function to prevent eccentric wear.

军工级高纯度基体材料，额外增加“调质”特殊热处理工艺，具有优异的高硬度与高韧性综合性能，耐磨不易断。

Military grade high purity matrix material, with additional "quenching and tempering" special heat treatment process, has excellent comprehensive properties of high hardness and high toughness, High resistance to wear and fracture.

NEW TECHNOLOGY

HIGH PURITY

HIGH PERFORMANCE

HPU84-19TD

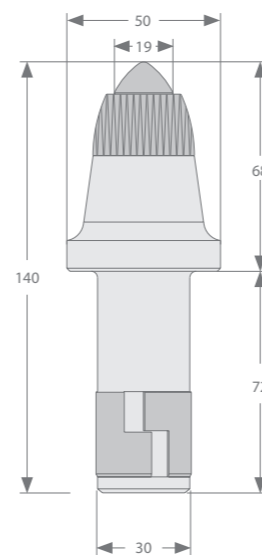

HPU84-22TD

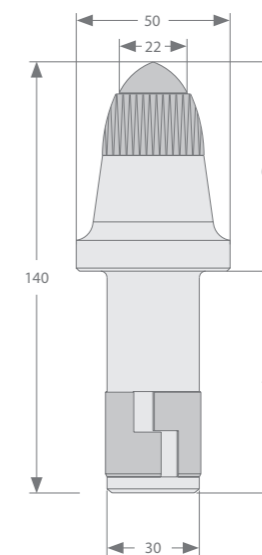

HPU85-17TD

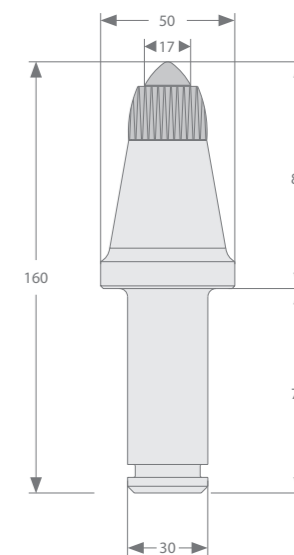

HPU85-19TD

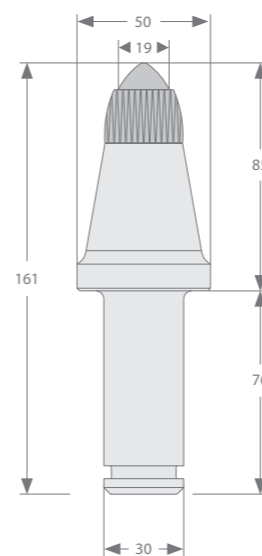

HPU92-17TD

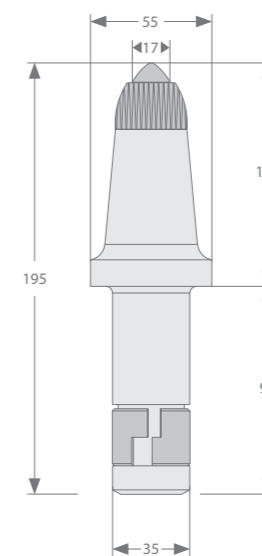

HPU92-19TD

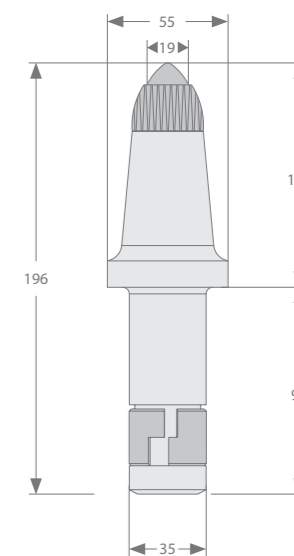

型号 Model	包装方式 Packaging Method	包装件数 Number of Packages	重量 / 箱 Weight/Box	整托箱数 Whole Pallet Box	整托重量 Whole Pallet Weight
HPU84-19TD	箱 Box	20	19KG	60 箱 / 60 Box	1140KG
HPU84-22TD	箱 Box	20	19.4KG	60 箱 / 60 Box	1164KG
HPU85-17TD	箱 Box	20	23.3KG	60 箱 / 60 Box	1398KG
HPU85-19TD	箱 Box	20	22KG	60 箱 / 60 Box	1320KG
HPU92-17TD	箱 Box	15	24.3KG	60 箱 / 60 Box	1458KG
HPU92-19TD	箱 Box	15	25KG	60 箱 / 60 Box	1500KG

# COAL PICK SERIES

## 煤截齿系列

Make Breakthrough in the control process of high-temperature active 3d melt compositions and achieve an ultra-purified metallurgical control, which leads to a high material purity.

突破了高温活性三维熔体成分控制工艺，实现超纯净冶金控制，材料更纯净。

新工艺、高纯度、高性能

NEW TECHNOLOGY

HIGH PURITY

HIGH PERFORMANCE



世界最先进的粗晶碳化钨合金，微观时效弥散强化设计，比传统合金寿命大幅提高。

The world's most advanced coarse-grained tungsten carbide alloy, micro-aging dispersion strengthening design, and significantly improved service life compared to conventional alloys.

恒普 "FREEFORM" 3D 打印技术，超级耐磨材料，增加合金寿命。恒普三维仿生结构 "3D-B&F" 技术，自适应旋转功能，防止偏磨。

Hengpu's "FREEFORM" 3D printing technology, together with the super wear-resistant materials greatly prolong the alloy life. Hengpu adopted bionic structure "3D-B&F" technology with the self-adaption function to prevent eccentric wear.

军工级高纯度基体材料，额外增加“调质”特殊热处理工艺，具有优异的高硬度与高韧性综合性能，耐磨不易断。

Military grade high purity matrix material, with additional "quenching and tempering" special heat treatment process, has excellent comprehensive properties of high hardness and high toughness, High resistance to wear and fracture.

HPU95-22TD

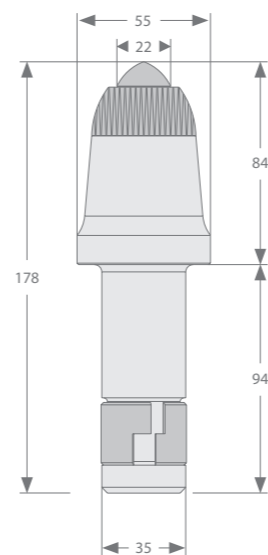

HPU95-25TD

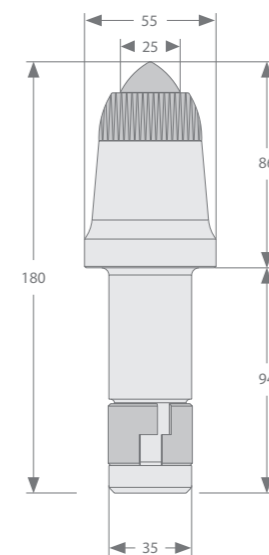

HPU95-30TD

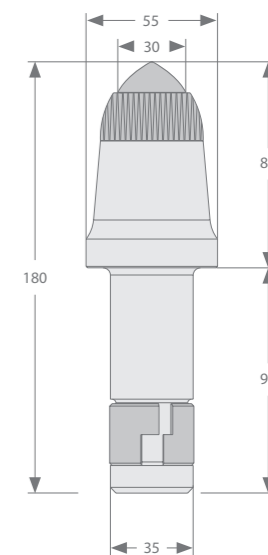

HPU170-22TD

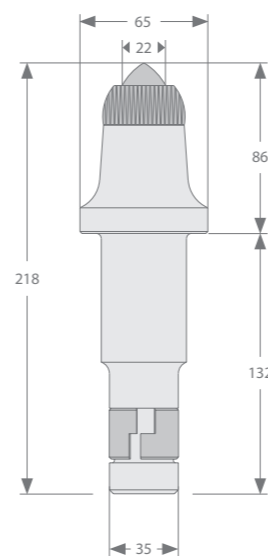

HPU170-25TD

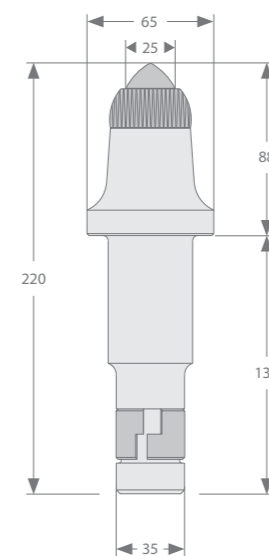

HPU170-30TD

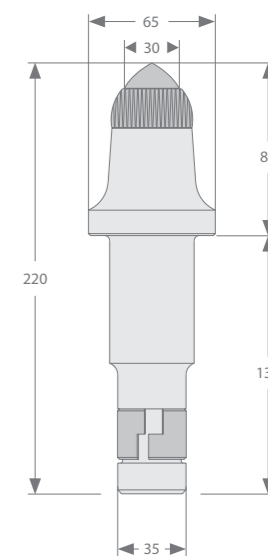

型号 Model	包装方式 Packaging Method	包装件数 Number of Packages	重量 / 箱 Weight/Box	整托箱数 Whole Pallet Box	整托重量 Whole Pallet Weight
HPU95-22TD	箱 Box	15	25KG	60 箱 / 60 Box	1500KG
HPU95-25TD	箱 Box	15	25.5KG	60 箱 / 60 Box	1530KG
HPU95-30TD	箱 Box	15	28.3KG	60 箱 / 60 Box	1698KG
HPU170-22TD	箱 Box	10	23.4KG	60 箱 / 60 Box	1404KG
HPU170-25TD	箱 Box	10	24.4KG	60 箱 / 60 Box	1464KG
HPU170-30TD	箱 Box	10	26KG	60 箱 / 60 Box	1560KG

# ROADHEADER SERIES

## 掘进机系列

Proposal of bionic 3D structure with adaptive rotation function, which leads to a more uniform tool wear and a superior design life.

提出了仿生 3D 结构，自适应旋转功能，刀具磨损更均匀，设计寿命完美体现。

新结构、高效率、高产出

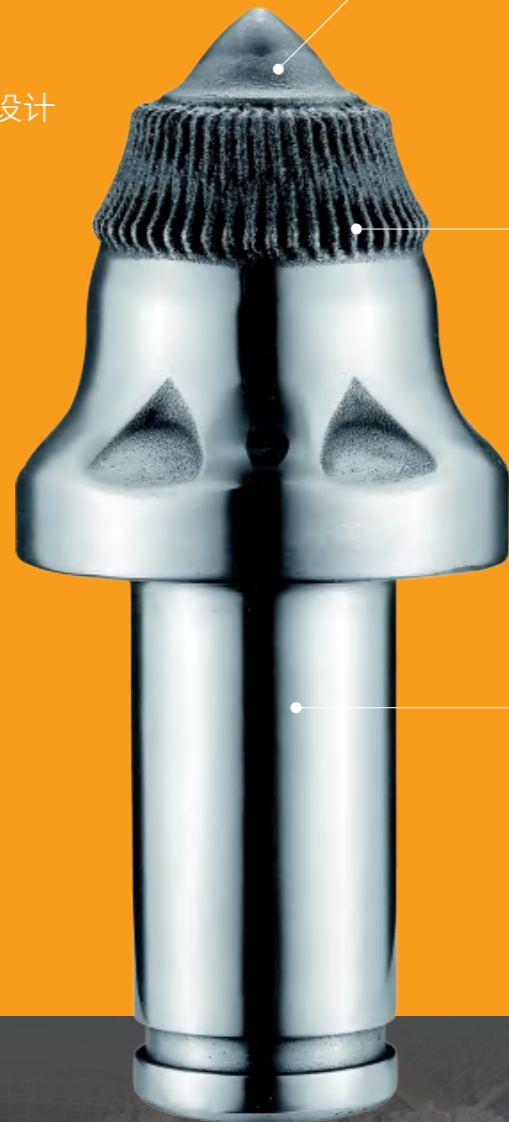

世界最先进的粗晶碳化钨合金，微观时效弥散强化设计，比传统合金寿命大幅提高。

The world's most advanced coarse-grained tungsten carbide alloy, micro-aging dispersion strengthening design, and significantly improved service life compared to conventional alloys.

恒普 "FREEFORM" 3D 打印技术，超级耐磨材料，增加合金寿命。恒普三维仿生结构 "3D-B&F" 技术，自适应旋转功能，防止偏磨。

Hengpu's "FREEFORM" 3D printing technology, together with the super wear-resistant materials greatly prolong the alloy life. Hengpu adopted bionic structure "3D-B&F" technology with the self-adaption function to prevent eccentric wear.

军工级高纯度基体材料，额外增加“调质”特殊热处理工艺，具有优异的高硬度与高韧性综合性能，耐磨不易断。

Military grade high purity matrix material, with additional "quenching and tempering" special heat treatment process, has excellent comprehensive properties of high hardness and high toughness, High resistance to wear and fracture.

- NEW STRUCTURE
- HIGH EFFICIENCY
- HIGH YIELD

### HENGPU (NINGBO) LASER TECHNOLOGY CO., LTD

HPS135D-25TD

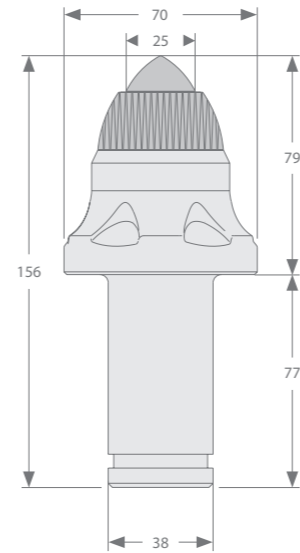

HPS135D-27TD

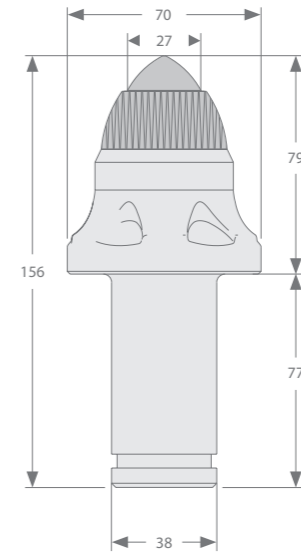

HPS260-30TD

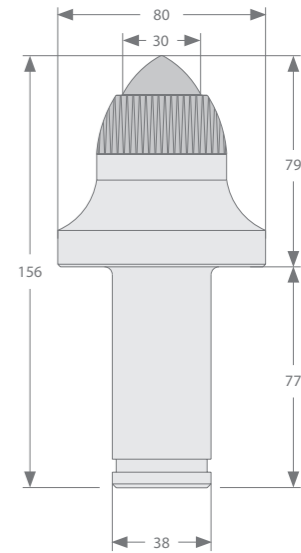

HPS260-34TD

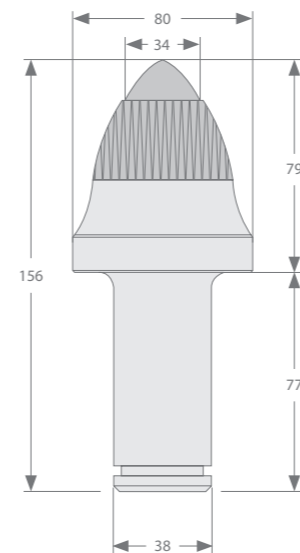

HPS360-30TD

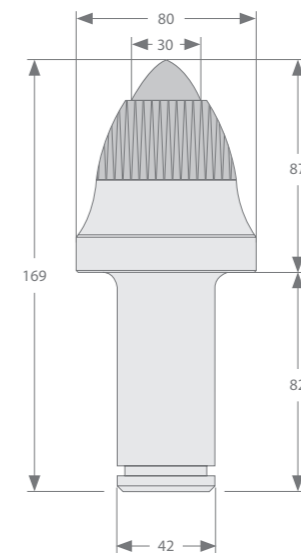

HPS360-34TD

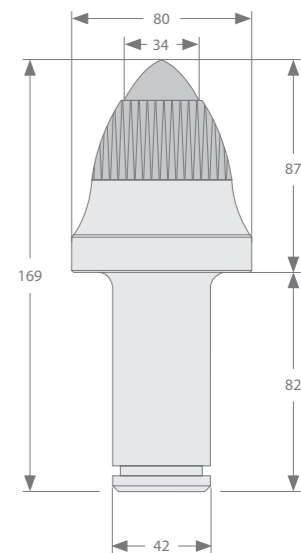

型号 Model	包装方式 Packaging Method	包装件数 Number of Packages	重量 / 箱 Weight/Box	整托箱数 Whole Pallet Box	整托重量 Whole Pallet Weight
HPS135D-25TD	箱 Box	10	19.5KG	60 箱 / 60 Box	1170KG
HPS135D-27TD	箱 Box	10	20KG	60 箱 / 60 Box	1200KG
HPS260-30TD	箱 Box	10	23KG	60 箱 / 60 Box	1380KG
HPS260-34TD	箱 Box	10	25.6KG	60 箱 / 60 Box	1536KG
HPS360-30TD	箱 Box	10	26KG	60 箱 / 60 Box	1560KG
HPS360-34TD	箱 Box	8	23.75KG	60 箱 / 60 Box	1425KG

# INTEGRATION OF STRUCTURE AND FUNCTION

Structural and functional integrated 3D printing ceramics: Good steel is used on the blade.

结构功能一体化3D打印陶瓷：

好钢用在刀刃上



应用领域：地铁、隧道、  
基建施工，石油、煤、天然气、  
矿山开采

**Application:** Construction of subway, tunnel and other infrastructures; extraction of oil, coal, natural gas and mines.

## SUBWAY



# ROTARY EXCAVATION SERIES

## 旋挖机系列

Breakthrough in metal-ceramic atomic bonding technology, a perfect combination of high hardness and high toughness, more than 10 times longer life than conventional materials.

突破金属 - 陶瓷原子键合技术，高硬度与高韧性完美结合，比传统材料寿命提高 10 倍以上。

新材料、高耐磨、高寿命



世界最先进的粗晶碳化钨合金，微观时效弥散强化设计，比传统合金寿命大幅提高。

The world's most advanced coarse-grained tungsten carbide alloy, micro-aging dispersion strengthening design, and significantly improved service life compared to conventional alloys.

恒普 "FREEFORM" 3D 打印技术，超级耐磨材料，增加合金寿命。恒普三维仿生结构 "3D-B&F" 技术，自适应旋转功能，防止偏磨。

Hengpu's "FREEFORM" 3D printing technology, together with the super wear-resistant materials greatly prolong the alloy life. Hengpu adopted bionic structure "3D-B&F" technology with the self-adaption function to prevent eccentric wear.

军工级高纯度基体材料，额外增加“调质”特殊热处理工艺，具有优异的高硬度与高韧性综合性能，耐磨不易断。

Military grade high purity matrix material, with additional "quenching and tempering" special heat treatment process, has excellent comprehensive properties of high hardness and high toughness, High resistance to wear and fracture.

NEW MATERIALS

HIGH WEAR RESISTANCE

LONG SERVICE LIFE

HP3055-19TD

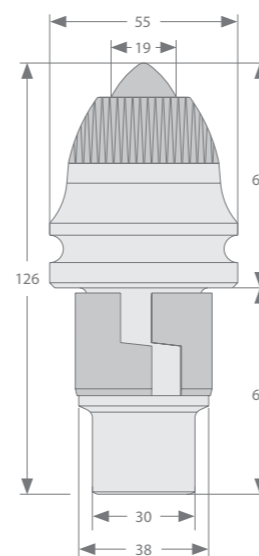

HP3055-22TD

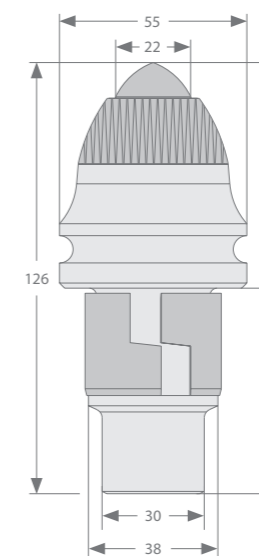

HP3060-19TD

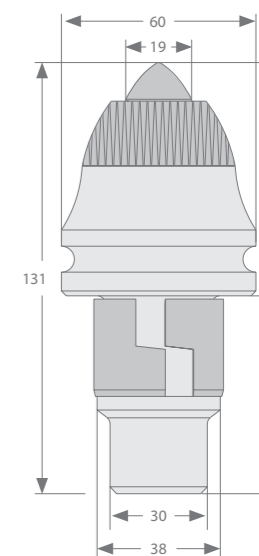

HP3060-22TD

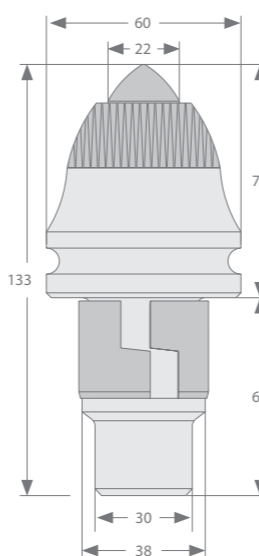

HP3060-25TD

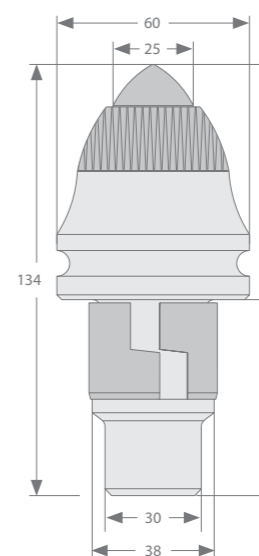

HP3060-30TD

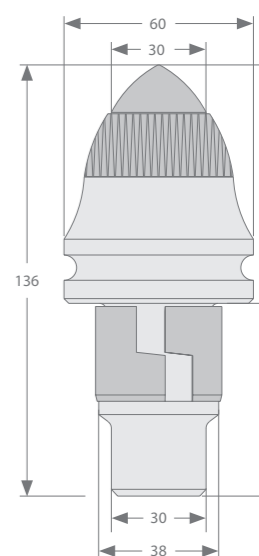

型号 Model	包装方式 Packaging Method	包装件数 Number of Packages	重量 / 箱 Weight/Box	整托箱数 Whole Pallet Box	整托重量 Whole Pallet Weight
HP3055-19TD	箱 Box	15	18.6KG	60 箱 / 60 Box	1116KG
HP3055-22TD	箱 Box	15	19KG	60 箱 / 60 Box	1140KG
HP3060-19TD	箱 Box	15	21.25KG	60 箱 / 60 Box	1275KG
HP3060-22TD	箱 Box	15	21.3KG	60 箱 / 60 Box	1278KG
HP3060-25TD	箱 Box	15	22.3KG	60 箱 / 60 Box	1338KG
HP3060-30TD	箱 Box	15	24.2KG	60 箱 / 60 Box	1452KG

# MILLING EXCAVATOR SERIES

## 铣挖机系列

Military product standards, strict material selection, rigorous production process and strict quality inspection.

军工产品标准，苛刻的选材，严谨的生产工艺，严格的质量检验。

高标准、高技术、高品质

HIGH STANDARD

HIGH TECHNOLOGY

HIGH QUALITY



世界最先进的粗晶碳化钨合金，微观时效弥散强化设计，比传统合金寿命大幅提高。

The world's most advanced coarse-grained tungsten carbide alloy, micro-aging dispersion strengthening design, and significantly improved service life compared to conventional alloys.

恒普 "FREEFORM" 3D 打印技术，超级耐磨材料，增加合金寿命。恒普三维仿生结构 "3D-B&F" 技术，自适应旋转功能，防止偏磨。

Hengpu's "FREEFORM" 3D printing technology, together with the super wear-resistant materials greatly prolong the alloy life. Hengpu adopted bionic structure "3D-B&F" technology with the self-adaption function to prevent eccentric wear.

军工级高纯度基体材料，额外增加“调质”特殊热处理工艺，具有优异的高硬度与高韧性综合性能，耐磨不易断。

Military grade high purity matrix material, with additional "quenching and tempering" special heat treatment process, has excellent comprehensive properties of high hardness and high toughness, High resistance to wear and fracture.

HPS120B-17TD

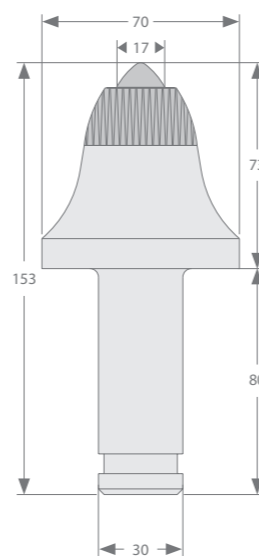

HPS120B-19TD

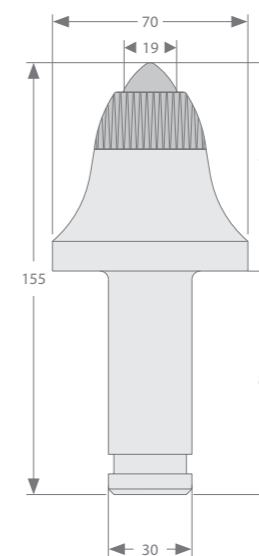

HPS120B-22TD

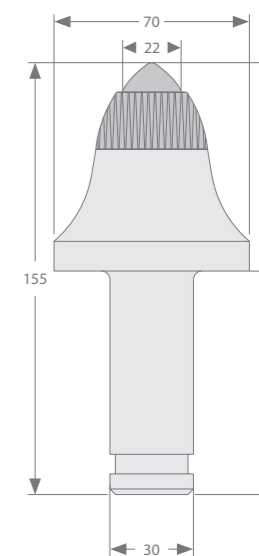

HPXW24B-13TD

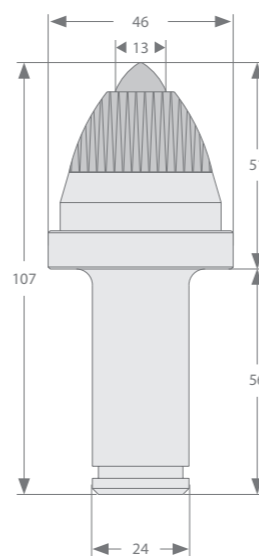

HPXW24B-17TD

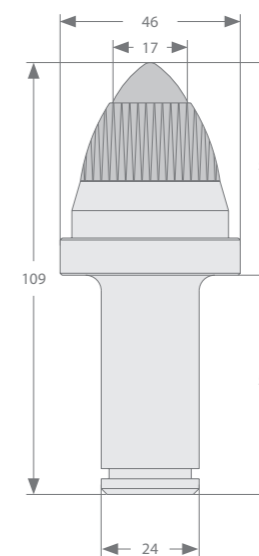

HPC31-17TD

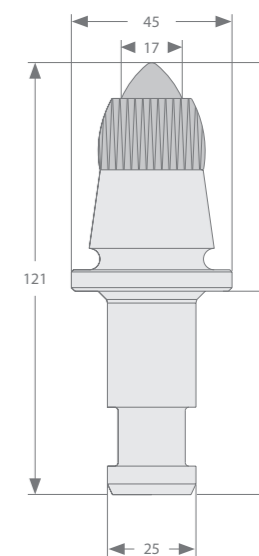

型号 Model	包装方式 Packaging Method	包装件数 Number of Packages	重量 / 箱 Weight/Box	整托箱数 Whole Pallet Box	整托重量 Whole Pallet Weight
HPS120B-17TD	箱 Box	15	21.3KG	60 箱 / 60 Box	1278KG
HPS120B-19TD	箱 Box	15	22.8KG	60 箱 / 60 Box	1368KG
HPS120B-22TD	箱 Box	15	23KG	60 箱 / 60 Box	1380KG
HPXW24B-13TD	箱 Box	40	22.4KG	60 箱 / 60 Box	1344KG
HPXW24B-17TD	箱 Box	40	25KG	60 箱 / 60 Box	1500KG
HPC31-17TD	箱 Box	40	22.8KG	60 箱 / 60 Box	1368KG

# INTRODUCTION OF MINING PICK PRODUCTS

## 矿用截齿产品介绍

类别 Category	型号 Model	合金类型 Alloy type			齿体头部 特征 Features of tooth head	切割条件 Cutting conditions					卡簧形式 Circlip			柄部 Handle			
		柱型 Column	蘑菇型 Mushroom	帽型 Hat		软 Soft	中硬 Medium hard	硬 Hard	高硬 Higher hard	极硬 Extremely hard	卡簧 Jump ring	卡环 Snap ring	挡圈 Retaining ring	直径 Diameter	长度 Length		
铣刨机 系列 MILLING MACHINE SERIES	HP20T2	●			耐磨 无火花 wear resistant without spark		●					●			--	91mm	
	HP20T2D	●											●			--	91mm
	HP20T2S	●											●			--	88.6mm
	HP22T2	●											●			--	92mm
	HPSN20-13D	●											●			--	88mm
	HPSN22-13D	●											●			--	93mm
采煤机 系列 COAL PICK SERIES	HPU47-19TD	●			耐磨 无火花 wear resistant without spark		●							●	30mm	159mm	
	HPU47-22TD	●													●	30mm	158mm
	HPU47-25TD	●													●	30mm	160mm
	HPU82-17TD	●						●					●			30mm	154mm
	HPU82-19TD	●						●					●			30mm	154mm
	HPU82-19TD (lengthen加长)	●						●					●			30mm	171mm
	HPU84-19TD	●						●					●			30mm	140mm
	HPU84-22TD	●						●					●			30mm	140mm
	HPU85-17TD	●						●					●			30mm	160mm
	HPU85-19TD	●						●					●			30mm	161mm
	HPU92-17TD	●						●					●			35mm	195mm
	HPU92-19TD	●						●					●			35mm	196mm
	HPU95-22TD	●						●					●			35mm	178mm
	HPU95-25TD	●							●				●			35mm	180mm
	HPU95-30TD	●											●			35mm	180mm
	HPU170-22TD	●							●				●			35mm	218mm
HPU170-25TD	●										●			35mm	220mm		
HPU170-30TD	●										●			35mm	220mm		

类别 Category	型号 Model	合金类型 Alloy type			齿体头部 特征 Features of tooth head	切割条件 Cutting conditions					卡簧形式 Circlip			柄部 Handle					
		柱型 Column	蘑菇型 Mushroom	帽型 Hat		软 Soft	中硬 Medium hard	硬 Hard	高硬 Higher hard	极硬 Extremely hard	卡簧 Jump ring	卡环 Snap ring	挡圈 Retaining ring	直径 Diameter	长度 Length				
掘进机 系列 ROADHEADER SERIES	HPS135D-25TD	●			耐磨 无火花 wear resistant without spark										●	38mm	156mm		
	HPS135D-27TD	●														●	38mm	156mm	
	HPS260-30TD	●														●	38mm	156mm	
	HPS260-34TD	●														●	38mm	156mm	
	HPU360-30TD	●														●	42mm	169mm	
	HPU360-34TD	●														●	42mm	169mm	
铣挖机 系列 MILLING EXCAVATOR SERIES	HPS120B-17TD	●			耐磨 wear resistant		●								●	30mm	153mm		
	HPS120B-19TD	●													●	30mm	155mm		
	HPS120B-22TD	●													●	30mm	155mm		
	HPXW24B-13TD	●						●								●	24mm	107mm	
	HPXW24B-17TD	●														●	24mm	109mm	
	HPC31-17TD	●														●	25mm	121mm	

类别 Category	型号 Model	合金类型 Alloy type			齿体头部 特征 Features of tooth head	切割条件 Cutting conditions	卡簧形式 Circlip			柄部 Handle		
		柱型 Column	蘑菇型 Mushroom	帽型 Hat			卡簧 Jump ring	卡环 Snap ring	挡圈 Retaining ring	直径 Diameter	长度 Length	
旋挖机 系列 ROTARY EXCAVATION SERIES	HP3055-19TD	●			耐磨 wear resistant	0-50 兆帕 MPa	●				30mm	126mm
	HP3055-22TD	●				50-100 兆帕 MPa	●				30mm	126mm
	HP3060-19TD	●				0-50 兆帕 MPa	●				30mm	131mm
	HP3060-22TD	●				50-100 兆帕 MPa	●				30mm	133mm
	HP3060-25TD	●				100-150 兆帕 MPa	●				30mm	134mm
	HP3060-30TD	●				>150 兆帕 MPa	●				30mm	136mm