

OCEM

ITALIAN QUALITY, GLOBAL MARKET



GENERAL CATALOGUE

Catalogue général

Catálogo General

通用目录





OCEM



OCEM's presses and finishing technologies are operating worldwide at the most important international concrete-agglomerate production plants and, thanks to the continuous research and development efforts, the company is today internationally recognized as the leading, most experienced and referenced supplier of hydraulic presses and complete plants for concrete agglomerated tiles and slabs



Les presses et les technologies de finition OCEM sont utilisées universellement dans les plus importantes usines internationales de production d'agglomérés en béton et, grâce aux efforts continus en recherche et développement, la Société est aujourd'hui internationalement reconnue comme le leader le plus expérimenté et référencé dans la fourniture de presses et installations complètes pour carreaux et dalles en béton.



Las prensas y tecnologías de acabado de OCEM operan en todo el mundo en las plantas de producción de conglomerado de concreto más importantes a nivel internacional. Gracias a los continuos esfuerzos de investigación y desarrollo, la empresa es hoy reconocida internacionalmente como el principal proveedor, con mayor experiencia y referencia en prensas hidráulicas y plantas completas para la fabricación de baldosas y losas de conglomerado de concreto.



OCEM 的湿法成型机和深加工设备在全球各地最重要的大型混凝土制品生产工厂都有运行。由于坚持不懈的研究和开发，OCEM公司现已成为国际公认的技术领先、最有经验和最有价值的湿法产品成型机与全套生产线供应商

ORGANIZATION, SKILLS
AND CAPABILITY TO
MANAGE COMPLEX
INDUSTRIAL PROJECT

**ITALIAN QUALITY
GLOBAL MARKET**

HYDRAULIC PRESSES FOR TILES AND SLABS

PERFORMANCE, DURABILITY AND USER-FRIENDLINESS

OPA540	Double layer	6
OPA650	Double layer	6
OPA400/6	Single and Double layer	7
OPA850	Double layer	7
OPA600/6	Single and Double layer	8
OPA1440/ES	Double layer	8
OPA740/6	Single and Double layer	9
OPA1280	Double layer	9
OPA1400/4	Single layer	10
OPA1400/6	Single and Double layer	10
OPA1480/6	Double layer	11
OPL840/3	Single layer	11
OPL1500	Single layer	12

ACCESSORIES FOR PRESSES

BEST TECHNOLOGIES FOR CONCRETE TILES & SLABS PRODUCTION

STAR 425 - STAR/TAP 625-825 - MOL 1500	Planetary Doser for concrete Mix.....	14
BM 140-240-440	Automatic Hopper for second Layer.....	14
FLEXA 160-240	Automatic Hopper for second layer.....	15
JIT 240-440-830 - ACCU 2000	Automatic Hopper for second Layer.....	15
TU 140-240-440-PROBO	Cup elevator for second layer recovery.....	16
VT 2000/B - PLUS/T	Plunging spreader for the first layer.....	16
RAS 440	Plunging spreader for the first layer.....	17

OTHER MACHINES

COMPLEMENTARY MACHINES FOR TURN-KEY PLANTS

OB1 - OB2	Automatic concrete batching and mixing plants.....	20
Mixer MG 100-250	Planetary Mixers for first and second layer mixture.....	20
Mixer OM8	Screw Mixer for second layer mixture.....	21
TILE-UP 140-160	Automatic system to pick-up and store fresh or dry tiles.....	21
ORS 900-1400	Fresh Tiles Rotation Device.....	22
HOC 900-1100-1400	Horizontal Automatic Tiles and Slabs Handling System.....	22
ROBOT 1-1R/2-2R	Automatic Finger Car.....	23
TILE TILTERS OT (STAR) - OBT (BARREL)	Devices to rotate tiles up-side-down.....	23
OLC 400-700-800-1000	Calibrating Machine for tiles and slabs.....	24
OL 400-700-800-1000	Grinding and Polishing Machine for tiles and slabs.....	24
DP 400-700-800-1000	Tiles drying path.....	25
HOP 100	Horizontal palletiser for tiles and slabs.....	25
VOP 100	Vertical palletiser for tiles and slabs.....	26
VAP LINES	CALIBRATING - GRINDING - POLISHING LINES for cement products (VAP lines)	27

SERVICES

ORIGINAL SPARE PARTS - AFTER SALE SERVICE - CONSULTING & PLANNING.....	29
--	----

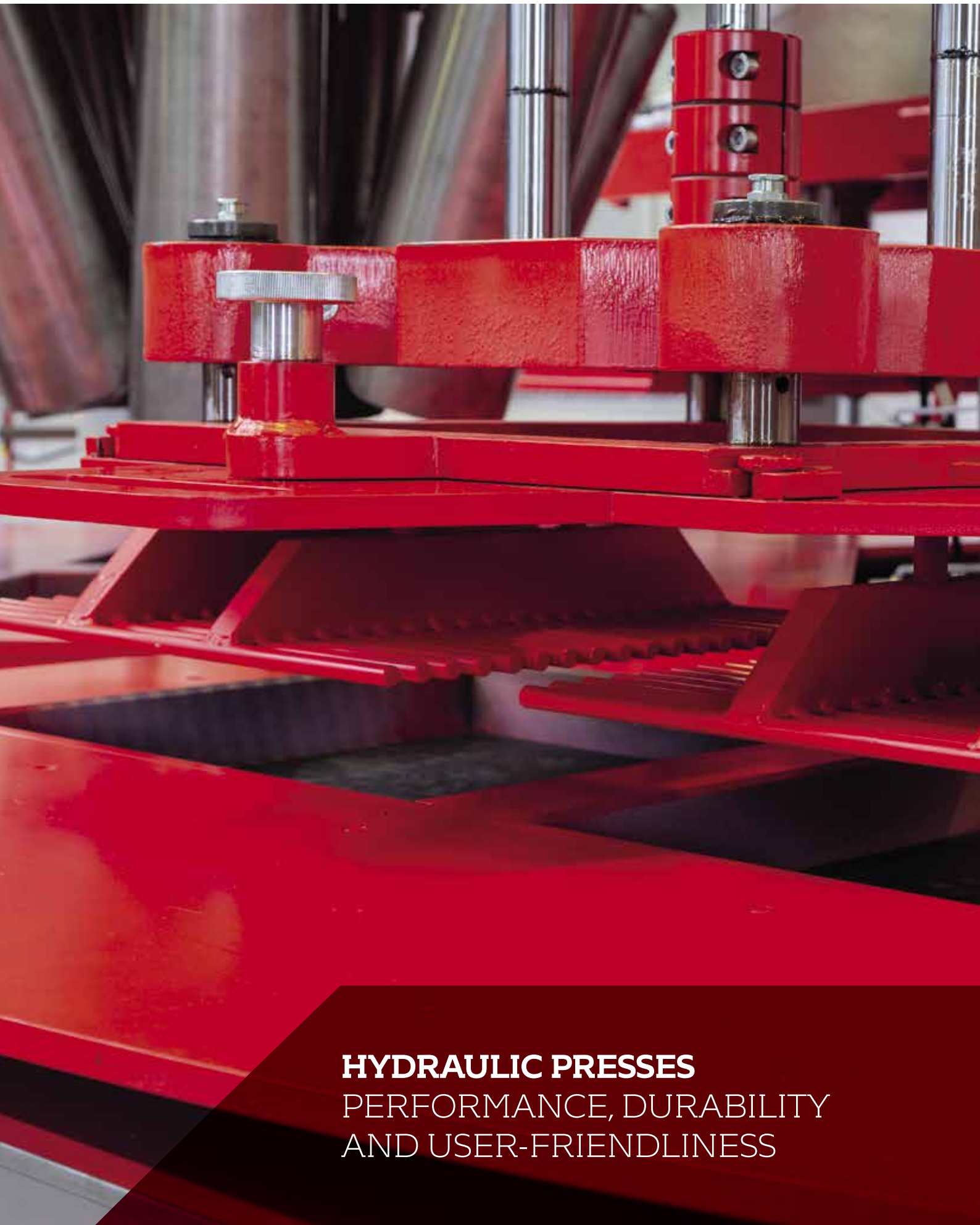

HYDRAULIC PRESSES
PERFORMANCE, DURABILITY
AND USER-FRIENDLINESS

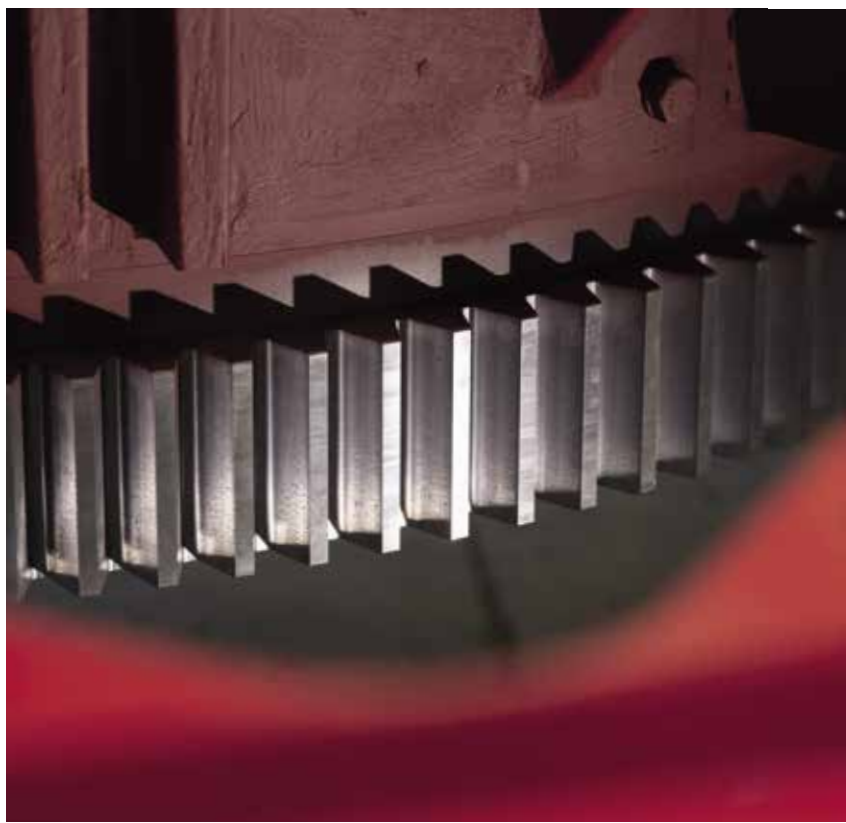
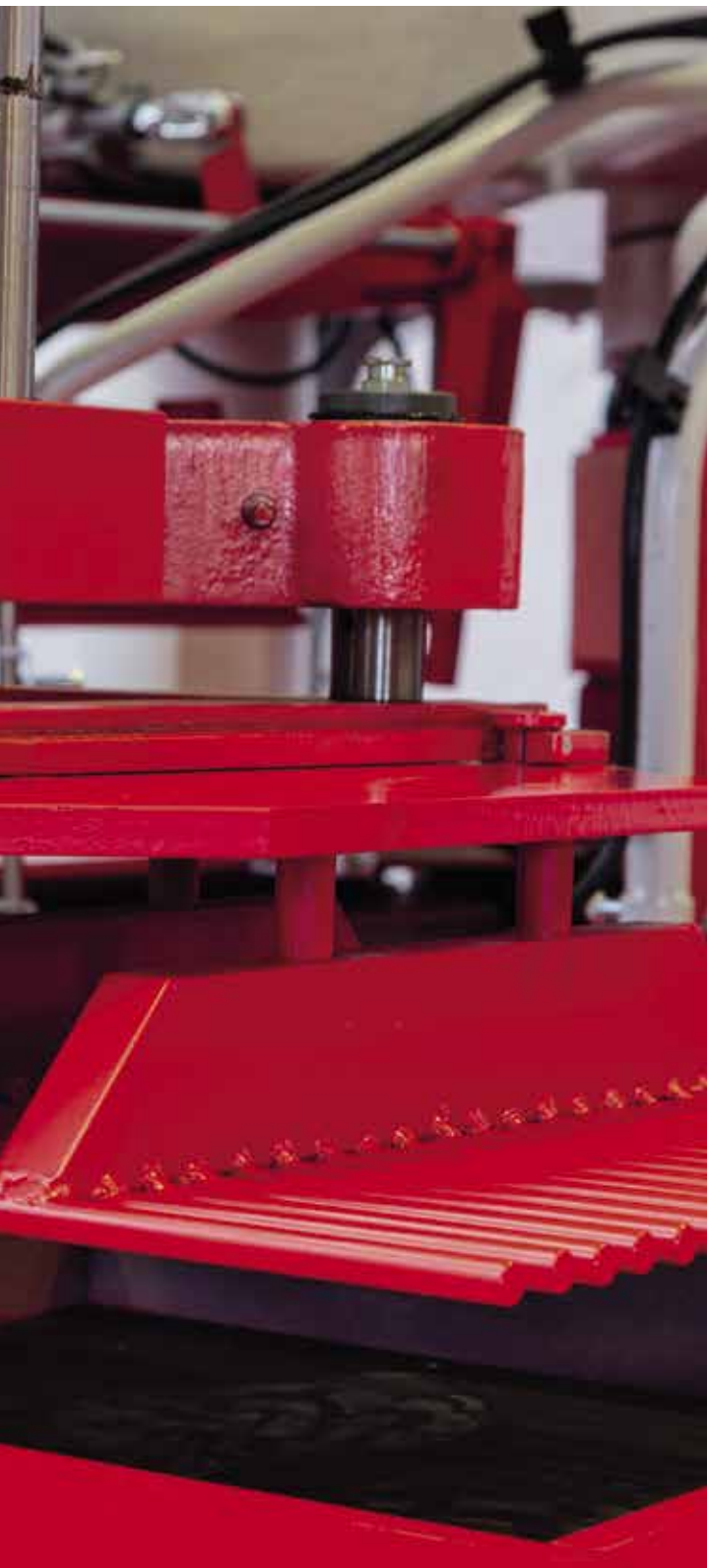

OCEM

OPA540



Double layer	
Double couche	
Doble capa	
双层产品	
Pressing power	
Puissance de compression	130 Ton.
Poder de Prensado	
成型压力	
Stations	
Stations	5
Estaciones	
工位	
Production capacity	
Capacité de production	190 - 370 m²/8h
Capacidad de Producción	
产量	

Production - Production - Producción - 产量

m²/h

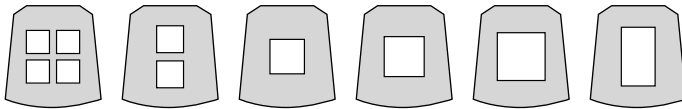

20x20 /4 25x25 /2 30x30 /1 33x33 /1 40x40 /1 30x50 /1

48 38 28 33 48 45

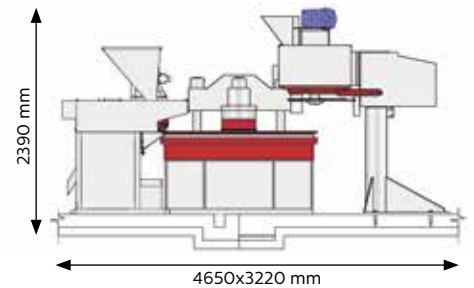

OPA650



Double layer	
Double couche	
Doble capa	
双层产品	
Pressing power	
Puissance de compression	300 - 350 Ton.
Poder de Prensado	
成型压力	
Stations	
Stations	6
Estaciones	
工位	
Production capacity	
Capacité de production	360 - 600 m²/8h
Capacidad de Producción	
产量	

Production - Production - Producción - 产量

m²/h

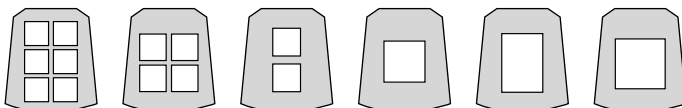

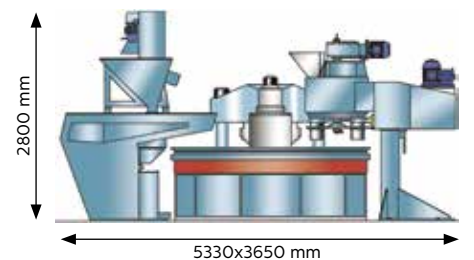

20x20 /6 25x25 /4 30x30 /2 33x33 /2 40x40 /1 40x60 /1 50x50 /1

72 75 54 - 65 48 72 75



OPA400/6



Single and Double layer	
Mono et Double couche	 
Monocapa y Doble capa	
通体产品 / 双层产品	
Pressing power	
Puissance de compression	400 Ton.
Poder de Prensado	
成型压力	
Stations	
Stations	6
Estaciones	
工位	
Production capacity	
Capacité de production	350 - 480 m²/8h
Capacidad de Producción	
产量	
2nd layer charger	
Chargeur de seconde couche	Optional
Cargador de 2º Capa	
底料放料器	

Production - Production - Producción - 产量

m²/h

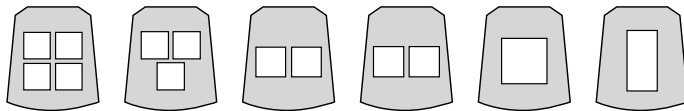

20x20 /4	25x25 /3	30x30 /2	33x33 /2	40x40 /1	30x60 /1
48	56	54	65	48	54

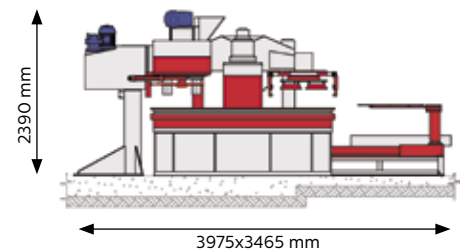

OPA850



Double layer	
Double couche	
Doble capa	
双层产品	
Pressing power	
Puissance de compression	300 - 350 Ton.
Poder de Prensado	
成型压力	
Prepressing	
Pré-compression	8 Ton.
Pre Prensado	
预压	
Stations	
Stations	8
Estaciones	
工位	
Production capacity	
Capacité de production	390 - 850 m²/8h
Capacidad de Producción	
产量	

Production - Production - Producción - 产量

m²/h

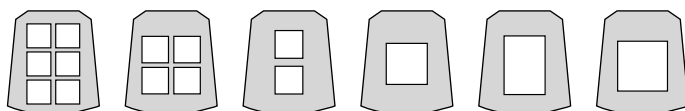

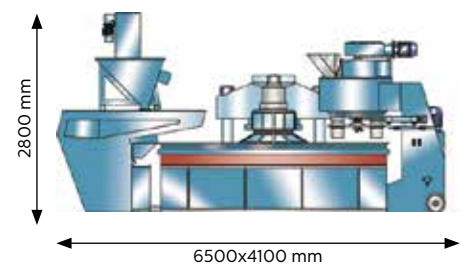

20x20 /6	25x25 /4	30x30 /2 33x33 /2	40x40 /1 50x50 /1	40x60 /1	60x60 /1
72	75	54 - 65	48 - 75	72	108



OPA600/6



Single and Double layer	
Mono et Double couche	 
Monocapa y Doble capa	
通体产品 / 双层产品	
Pressing power	
Puissance de compression	600 Ton.
Poder de Prensado	
成型压力	
Stations	
Stations	6
Estaciones	
工位	
Production capacity	
Capacité de production	520 - 780 m²/8h
Capacidad de Producción	
产量	
2nd layer charger	
Chargeur de seconde couche	Optional
Cargador de 2º Capa	
底料放料器	

Production - Production - Producción - 产量 m²/h

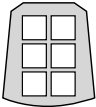
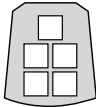
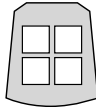
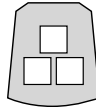
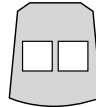
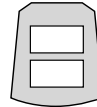
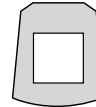
						
20x20 /6	25x25 /5	30x30 /4	33x33 /3	40x40 /2	30x60 /2	50x50 /1 60x60 /1
72	94	108	98	96	108	75 - 108

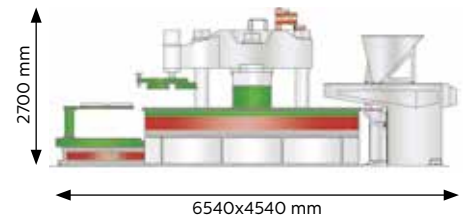

OPA1440/ES



Double layer	
Double couche	
Doble capa	
双层产品	
Pressing power	
Puissance de compression	520 - 600 Ton.
Poder de Prensado	
成型压力	
Prepressing	
Pré-compression	20 Ton.
Pre Prensado	
预压	
Stations	
Stations	7
Estaciones	
工位	
Production capacity	
Capacité de production	600 - 1200 m²/8h
Capacidad de Producción	
产量	

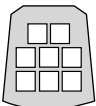
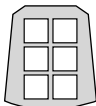
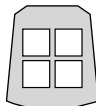
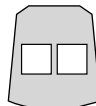
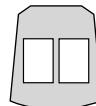
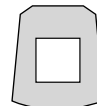
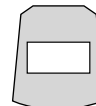

Production - Production - Producción - 产量 m²/h

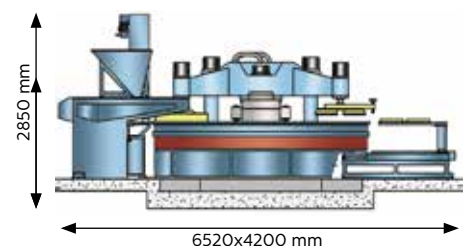
						
20x20 /8 25x25 /8	25x25 /6	30x30 /4 33x33 /4	40x40 /2	40x60 /2	50x50 /1 60x60 /1	40x80 /1
96 - 150	112,5	108 - 130	96	144	75 - 108	96



OPA740/6



Single and Double layer	
Mono et Double couche	 
Monocapa y Doble capa	
通体产品 / 双层产品	
Pressing power	
Puissance de compression	740 Ton.
Poder de Prensado	
成型压力	
Stations	
Estaciones	6
工位	
Production capacity	
Capacité de production	570 - 960 m²/8h
Capacidad de Producción	
产量	
2nd layer charger	
Chargeur de seconde couche	Optional
Cargador de 2º Capa	
底料放料器	

Production - Production - Producción - 产量 m²/h

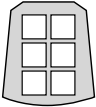
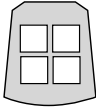
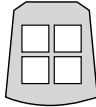
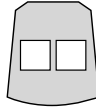
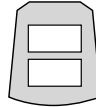
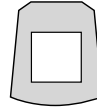
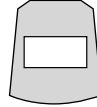
						
20x20 / 6 25x25 / 6	30x30 / 4	33x33 / 4	40x40 / 2	30x60 / 2	50x50 / 1 60x60 / 1	40x80 / 1
72 - 112	108	130	96	108	75 - 108	96

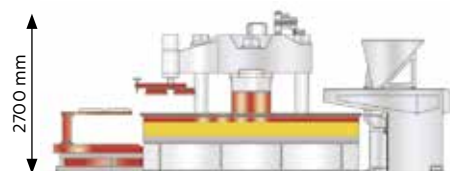

6540x4540 mm

OPA1280



Double layer	
Double couche	
Doble Capa	
双层产品	
Pressing power	
Puissance de compression	1200 Ton.
Poder de Prensado	
成型压力	
Prepressing	
Pré-compression	80 Ton.
Pre Prensado	
预压	
Stations	
Estaciones	7
工位	
Production capacity	
Capacité de production	760 - 1890 m²/8h
Capacidad de Producción	
产量	

Production - Production - Producción - 产量 m²/h

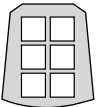
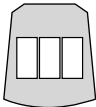
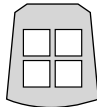
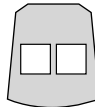
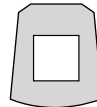
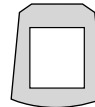
					
30x30 / 6 33x33 / 6	30x60 / 3	40x40 / 4	40x60 / 2 50x50 / 2	60x60 / 1 90x90 / 1	90x100 / 1
162 - 196	162	192	144 - 150	108 - 240	270



9120x5070 mm

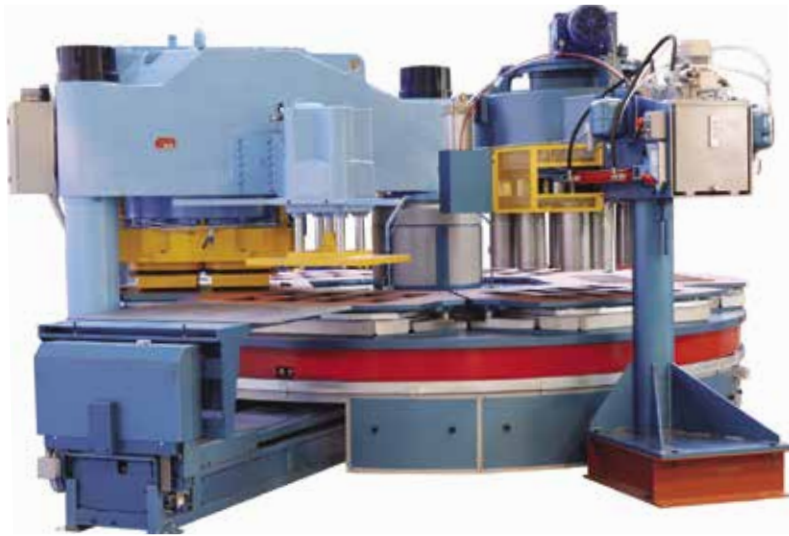

OPA1400/4



Single Layer	
Mono-couche	
Monocapa	
通体产品	
Pressing power	
Puissance de compression	1400 Ton.
Poder de Prensado	
成型压力	
Stations	
Stations	4
Estaciones	
工位	
Production capacity	
Capacité de production	1200 - 1800 m²/8h
Capacidad de Producción	
产量	

Production - Production - Producción - 产量

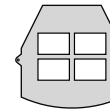
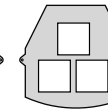
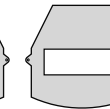
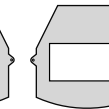

m²/h

					
33x33 / 8	40x40 / 6	40x60 / 4	50x50 / 3	40x160 / 1	60x160 / 1
261	280	288	225	192	288





OPA1400/6



Single and Double layer	
Mono et Double couche	 
Monocapa y Doble capa	
通体产品 / 双层产品	
Pressing power	
Puissance de compression	1400 Ton.
Poder de Prensado	
成型压力	
Stations	
Stations	6
Estaciones	
工位	
Production capacity	
Capacité de production	800 - 1550 m²/8h
Capacidad de Producción	
产量	
2nd layer charger	
Chargeur de seconde couche	Optional
Cargador de 2 ^o Capa	
底料放料器	

Production - Production - Producción - 产量

m²/h

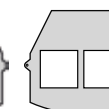
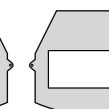
				
33x33 / 6	40x40 / 4	40x60 / 3 40x80 / 3	50x50 / 2 60x60 / 2	60x120 / 1
196	192	216 - 288	150 - 216	216

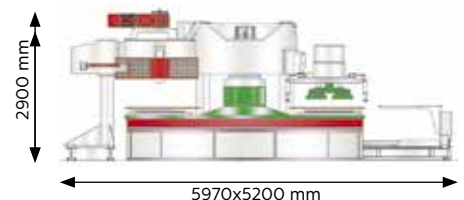

OPA1480/6

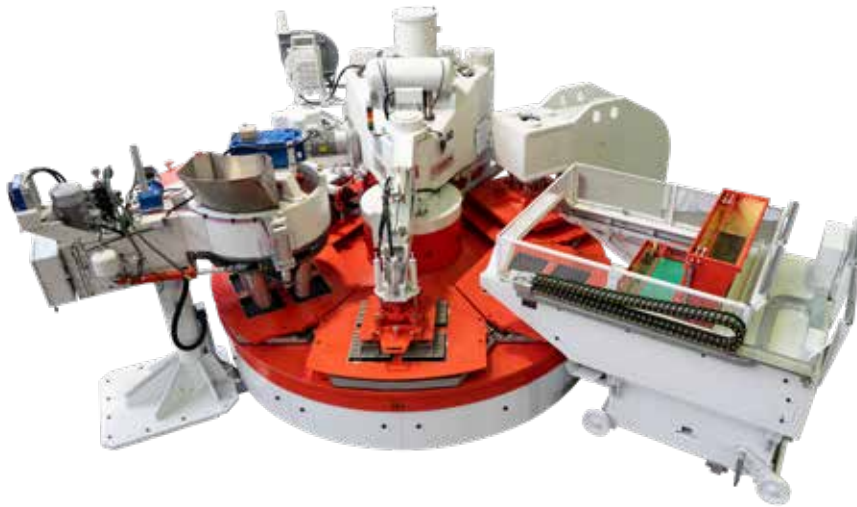

Double layer	
Double couche	
Doble Capa	
双层产品	
Pressing power	
Puissance de compression	1400 Ton.
Poder de Prensado	
成型压力	
Prepressing	
Pré-compression	80 Ton.
Pre Prensado	
预压	
Stations	
Stations	6
Estaciones	
工位	
Production capacity	
Capacité de production	1050 - 1950 m²/8h
Capacidad de Producción	
产量	



Production - Production - Producción - 产量 m²/h

30x30 /6 33x33 /6	40x40 /4 50x50 /4	60x60 /2	60x120 /1	100x100 /1
162 - 196	192 - 300	216	216	300

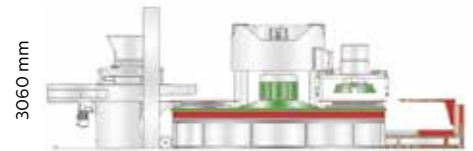

9080x5440 mm

OPL840/3



Single Layer	
Mono-couche	
Monocapa	
通体产品	
Pressing power	
Puissance de compression	840 Ton.
Poder de Prensado	
成型压力	
Stations	
Stations	3
Estaciones	
工位	
Production capacity	
Capacité de production	400 - 600 m²/8h
Capacidad de Producción	
产量	



Production - Production - Producción - 产量 m²/h

25x25 /6	30x30 /4 33x33 /4	40x40 /2	40x60 /2	60x60 /1	40x120 /1	50x100 /1
56	54 - 66	50	72	53	72	75

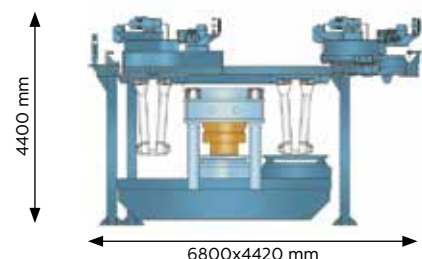





OPL1500

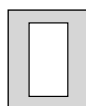
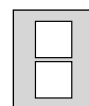

Single Layer	
Mono-couche	
Monocapa	
通体产品	
Pressing power	
Puissance de compression	1500 Ton.
Poder de Prensado	
成型压力	
Stations	
Estaciones	3
工位	
Production capacity	
Capacité de production	240 - 480 m²/8h
Capacidad de Producción	
产量	

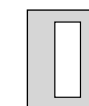
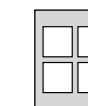
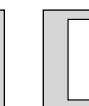
Production - Production - Producción - 产量 m²/h

						
60x120 /1	60x60 /2	30x60 /4	40x120 /1	50x50 /4	60x160 /1	100x100 /1
43	43	43	30	60	58	60

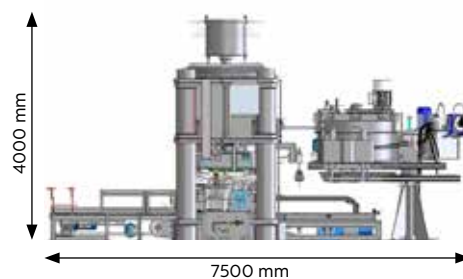

NOTE



OCEM

ACCESSORIES FOR PRESSES
BEST TECHNOLOGIES
FOR CONCRETE TILES & SLABS PRODUCTION

STAR 425 - STAR/TAP 625-825 - MOL 1500

Planetary Doser for concrete mix

Doseur Planétaire pour béton de parement

Dosificador Planetario para la mezcla de concreto

行星式面料机



BM 140-240-440

Automatic Hopper for Second Layer

Trémie Automatique pour Seconde Couche

Tolva Automática para la Segunda Capa

全自动底料布料机



FLEXA 160-240

Automatic Hopper for second layer for all presses from 130T to 740T

Trémie automatique pour la seconde couche pour toutes les presses de 130T à 740T

Tolva automática para la segunda capa para todas las prensas desde 130T hasta 740T

全自动底料布料机，适用于130吨到740吨的所有成型主机

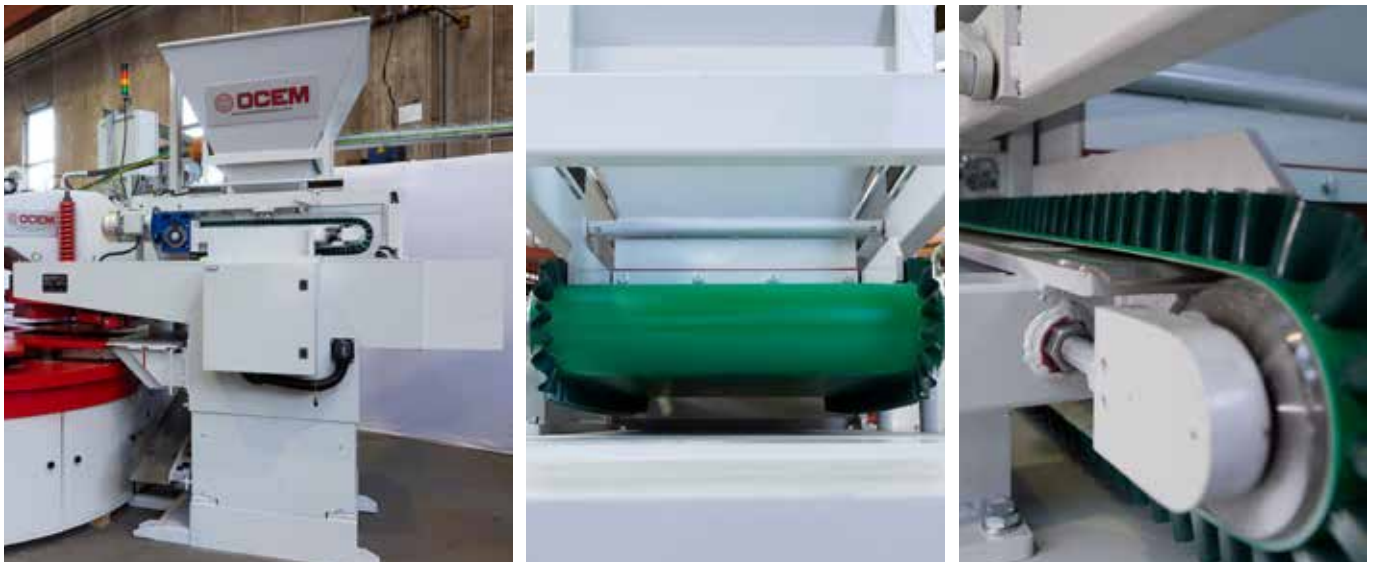

JIT 240-440-830 - ACCU 2200

Automatic Hopper for second layer with feeding/waiting hopper ACCU2200

Trémie automatique pour seconde couche avec trémie d'alimentation/attente mod. ACCU2200

Tolva automática para segunda capa con alimentador de tolvas ACCU2200

全自动底料布料机上的送料/待料器ACCU 2200



TU 140-240-440-PROBO

Cup elevator for second layer recovery

Elevateur a godets pour la récupération de la seconde couche

Elevador de cangilones para la recuperacion de la segunda capa

提升式底料回收装置



VT 2000/B

Plunging spreader for the first layer

Etaleur plongeant de la première couche

Esparcidor de pasta para la primera capa

面料摊铺器



PLUS/T

Plunging spreader for the first layer with rotating head for faster cleaning

Etaleur plongeant de la première couche avec tête rotative pour un nettoyage plus rapide

Esparcidor de pasta para la primera capa con cabezal giratorio para una limpieza más rápida

头部可旋转，清洁更便捷的面料摊铺器



RAS 440

Servocontrolled plunging spreader for the first layer for big tiles and slabs

Etaleur plongeant de la première couche pour grands carreaux et dalles

Esparcidor de pasta para la primera capa para grandes baldosas y losas

伺服控制的大块产品面料摊铺器



NOTE



OTHER MACHINES
COMPLEMENTARY MACHINES
FOR TURN-KEY PLANTS



OCEM



OB1-OB2

Automatic concrete batching and mixing plants

Centrales Automatique de préparation et malaxage de béton

Plantas Automáticas de Dosificación y Mezcla de Hormigón

全自动配料搅拌系统



MIXER MG 100-250

Planetary Mixers for first and second layer mixture

Malaxeur planétaire pour mélange de première et seconde couche

Mezcladoras Planetarias para la primera y segunda capa

行星式面料搅拌机和底料搅拌机



MIXER OM8

Screw Mixer for Second Layer mixture

Malaxeur à vis pour mélange de Seconde Couche

Mezcladora a Tornillo para la Segunda Capa

螺旋式底料搅拌机



TILE UP 140-160

Automatic system to pick-up and store fresh or dry tiles

Dispositif Automatique de préhension et de stockage pour carreaux frais ou secs

Sistema Automático para recoger y almacenar baldosas frescas o secas

湿坯或干坯产品全自动取放系统



ORS 900-1400

Tiles Rotation Device

Retourneur de Carreaux

Dispositivo de Rotación de baldosas

产品翻转装置

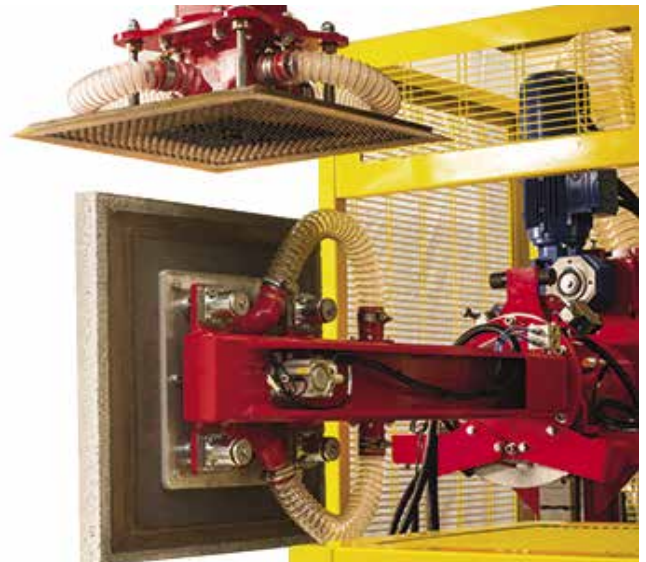
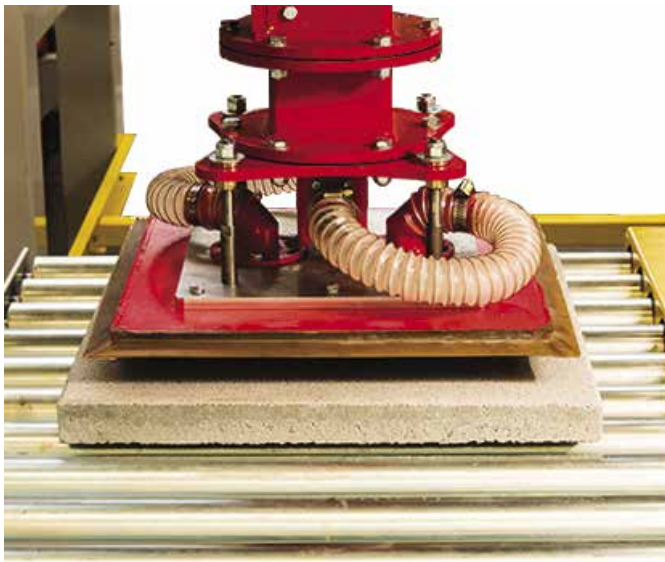

HOC 900-1100-1400

Horizontal Automatic Tiles and Slabs Handling System

Système de Manutention Horizontale Automatique pour carreaux et dalles

Sistema Automático Horizontal de Manipulación de baldosas y losas

产品平放全自动系统



ROBOT 1-1R/2-2R

Automatic Finger Car

Transbordeur Mère/Fille Automatique

Carro Transbordador Automático de bandejas

全自动字母车



TILE TILTERS OT (STAR) - OBT (BARREL)

Devices to rotate tiles up-side-down for finishing or palletizing

Dispositifs pour pivoter les carreaux à l'envers pour la finition ou la palettisation

Dispositivos para girar las baldosas boca abajo para el acabado o la paletización

将产品翻转以进行深加工或打包的装置



OLC 400-700-800-1000

Calibrating machine for tiles and slabs
Calibreuse pour carreaux et dalles
Maquina Calibradora para baldosas y losas
产品定厚设备



OL 400-700-800-1000

Grinding and Polishing Machine for tiles and slabs
Gréseuse et Polisseuse pour carreaux et dalles
Maquina pulidora y Abrillantadora para baldosas y losas
产品磨光和抛光设备

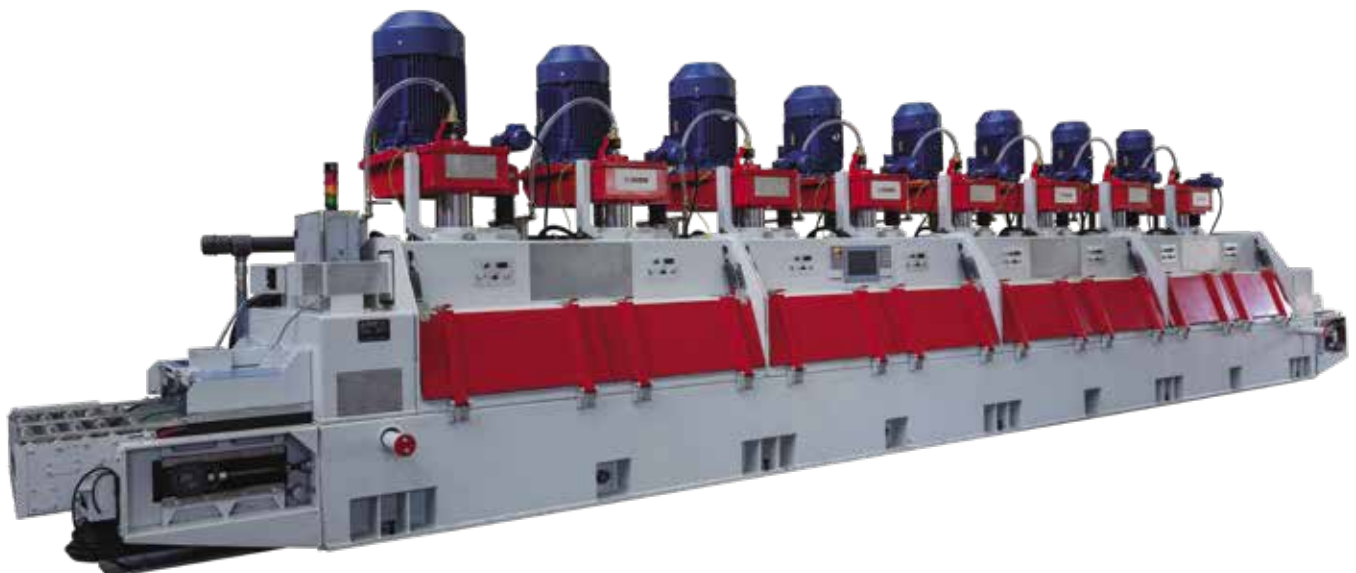

DP 400-700-800-1000

Tiles drying path

Chemin de séchage des carreaux

Ruta de secado de baldosas

产品干燥处理线



HOP 100

Horizontal palletiser for tiles and slabs

Palettiseur horizontal pour carreaux et dalles

Paletizador horizontal para baldosas y losas

产品平放式打包机



VOP 100

Vertical palletiser for tiles and slabs
Palettiseur vertical pour tuiles et dalles
Paletizador vertical para baldosas y losas
产品立放式打包机



NOTE



OCEM

VAP LINES

SURFACE TREATMENT LINES FOR PAVERS,
BLOCKS AND CURBSTONES

VAP LINES

CALIBRATING – GRINDING – POLISHING LINES for cement products (VAP lines)

OCEM, in collaboration with Co. PEDRINI, developed and produced complete calibrating, grinding and polishing machines with useful working width of 1200 mm to treat the surfaces of concrete products like i.e. pavers, blocks and kerbstones usually produced with concrete block manufacturing systems and vibro presses.

OCEM can design and manufacture also complete finishing lines for any kind of surface treatment like i.e. shot blasting, brushing, coating, splitting, etc. including also the boundary automations to feed and unload the process line.

LIGNES DE CALIBRAGE - BROYAGE - POLISSAGE pour produits cimentaires (lignes VAP)

OCEM, en collaboration avec la société PEDRINI, a développé et produit des machines complètes de calibrage, de meulage et de polissage avec une largeur de travail utile de 1200 mm pour traiter les surfaces de produits en ciment comme par ex. Pavés, blocs et bordures de trottoir généralement produits avec des systèmes de fabrication de blocs de béton et des presses vibrantes.

OCEM peut concevoir et fabriquer également des lignes de finition complètes pour tout type de traitement de surface comme par ex. grenailage, brosseage, fendage, etc. y compris également les automatisations des limites pour alimenter et décharger la ligne de processus.



VAP LINES

LÍNEAS DE CALIBRADO - MOLIENDA - PULIDO para productos de cemento (líneas VAP)

OCEM, en colaboración con Co. PEDRINI, desarrolló y produjo máquinas completas de calibrado, esmerilado y pulido con un ancho de trabajo útil de 1200 mm para tratar las superficies de productos de cemento como, por ejemplo, adoquines, bloques y bordillos, generalmente producidos con sistemas de fabricación de bloques de hormigón y vibro prensas. OCEM puede diseñar y fabricar también líneas completas de acabado para cualquier tipo de tratamiento de superficie como, por ejemplo, granallado, cepillado, división, etc. incluyendo también los automatismos de contorno para alimentar y descargar la línea de proceso.

水泥制品深加工处理线（VAP 处理线）定厚-磨光-抛光

OCEM 与 PEDRINI 两公司共同合作，开发并生产全套的定厚、磨光和抛光设备，它们的最大工作宽度可达 1200 毫米，可用于处理通常由振动成型机生产的水泥制品的表面，例如路面砖、砌块和路缘石等。

OCEM 还可以设计和生产任何类型的表面深加工处理全套生产线，例如抛丸、刷面、喷涂、劈裂等，并包括与这些深加工处理线配套的全自动进给和卸载装置





OCEM

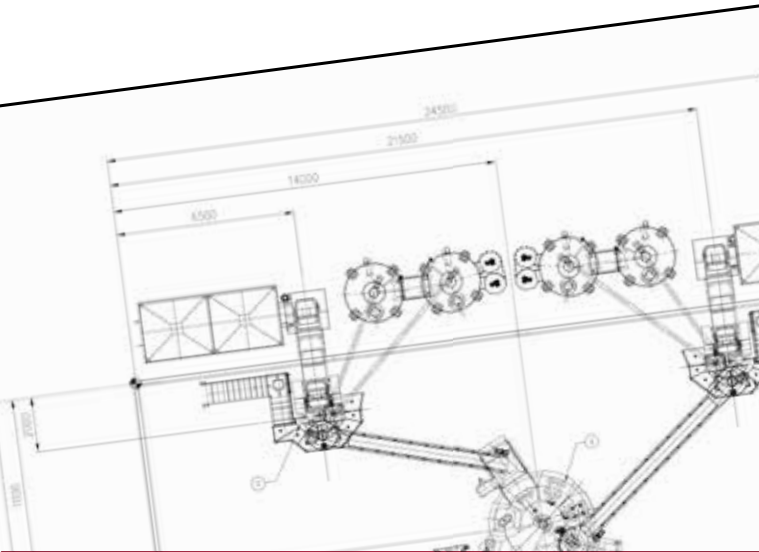

SERVICES

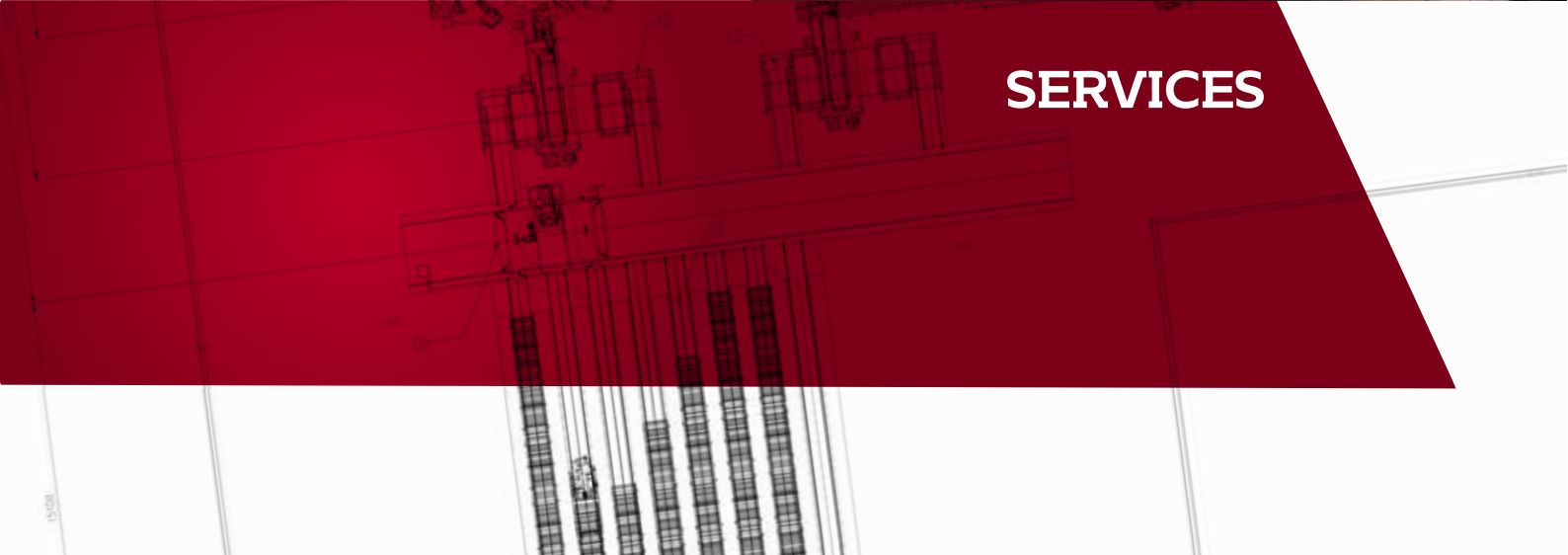

ORIGINAL SPARE PARTS

OCEM Spare Parts Dept. follows all Customers with passion, consciousness and promptness.

The use of original spare and wear parts is a guarantee of success, limiting downtimes and loss of production.

OCEM is able to supply original spare and wear parts for all our machines even for the oldest ones.

Le département des pièces de rechanges d'OCEM suit tous les clients avec passion, conscience et rapidité.

L'utilisation de pièces de rechange et d'usure originales est une garantie de succès, limitant les temps d'arrêt et les pertes de production.

OCEM peut fournir des pièces de rechange et d'usure originales pour toutes ses machines, même les plus anciennes.

El Departamento de Repuestos OCEM sigue a todos los Clientes con pasión, conciencia y prontitud.

El uso de recambios y piezas de desgaste originales es una garantía de éxito, limitando los tiempos de inactividad y las pérdidas de producción.

OCEM es capaz de suministrar repuestos y piezas de desgaste originales para todas nuestras máquinas, incluso las más antiguas.

原装备件

OCEM 备件部门以热情、自觉和及时的态度关注所有客户。

使用原装备件和零件是成功的保证，可减少生产的停机时间和损失。

OCEM 能够为我们所有的机器，甚至是最旧的机器，都能提供原厂备件和零件。

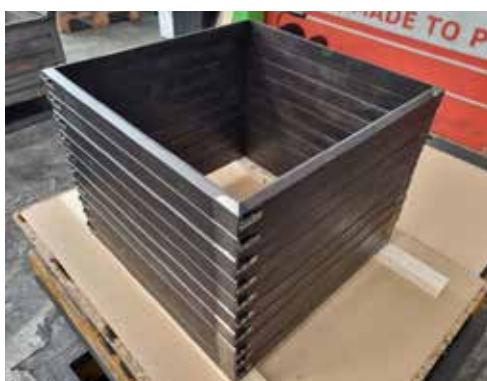
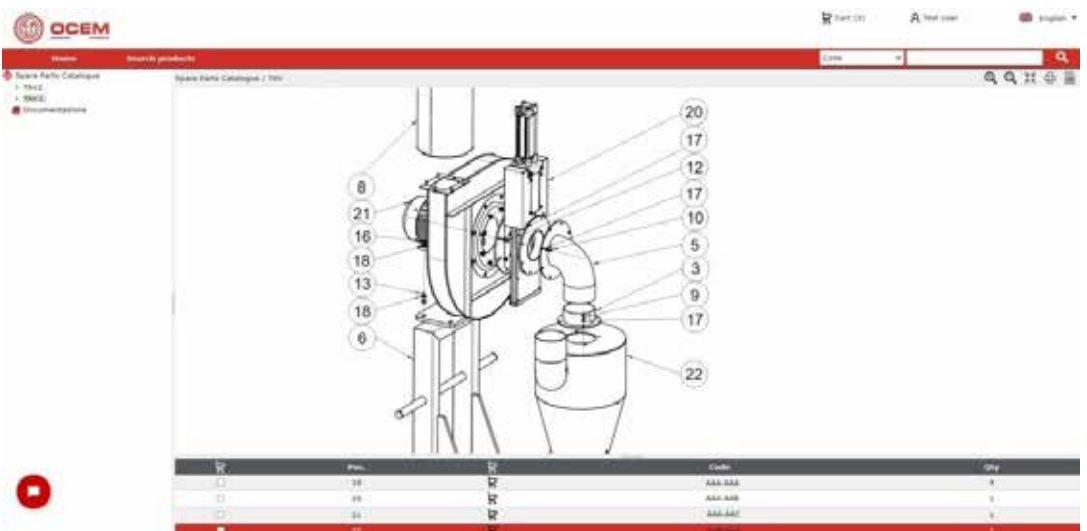

AFTER SALE SERVICE

Together with Spare Parts Dept., OCEM's After Sales Service, with its specialized team and skilled technicians offers a quick, efficient and professional service to all machines spread worldwide helping Customer's operators to improve efficiency and productivity minimising machines downtime.

Avec le département des pièces de recharge, le service après-vente d'OCEM, avec son équipe spécialisée et ses techniciens qualifiés, offre un service rapide, efficace et professionnel à toutes les machines réparties dans le monde entier, aidant les opérateurs des clients à améliorer l'efficacité et la productivité en minimisant les temps d'arrêt des machines.

Junto con el Departamento de Piezas de Repuestos, el Servicio Postventa de OCEM, con su equipo especializado y técnicos cualificados, ofrece un servicio rápido, eficaz y profesional a todas las máquinas repartidas por todo el mundo, ayudando a los operadores de los clientes a mejorar la eficacia y la productividad y minimizando el tiempo de inactividad de las máquinas.

售后服务

OCEM 的售后服务部门与备件部门一起，凭借其专业团队和熟练的技术人员，为遍布全球的所有机器提供快速、高效和专业的服务，帮助客户的操作者提高效率 and 产量，最大限度地减少机器停机时间。



CONSULTING & PLANNING

OCEM Sales and Technical depts. are at disposal to consider and study any Customer's idea or project and supply proper technical solutions to optimize the economic investment and the production capacities.

All OCEM plants are tailored following the Customer's requests.

Les services commerciaux et techniques d'OCEM sont à la disposition du client pour étudier toute idée ou projet et fournir des solutions techniques appropriées pour optimiser l'investissement économique et les capacités de production.

Toutes les installations OCEM sont conçues sur mesure en fonction des demandes du client.

Los departamentos técnico y de ventas de OCEM están a disposición del cliente para estudiar cualquier idea o proyecto y proporcionar soluciones técnicas adecuadas para optimizar la inversión económica y la capacidad de producción.

Todas las instalaciones OCEM se diseñan a medida según las necesidades del cliente.

咨询与规划

OCEM 销售和技术部门。随时考虑和研究任何客户的想法或项目，并提供适当的技术解决方案，以优化投资和产能。所有 OCEM 的设备工厂都是根据客户的要求量身定制。



HOW
TO REACH
US



OCEM

OCEM 1



HEADQUARTER

SALES DEPT.

SPARE PARTS DEPT.

MECHANICAL MACHINING DEPT.

**Via Gran Bretagna, 107
50126 Firenze - Italy
Ph: +39 055 680753
sales@ocemflorence.com**

OCEM 2



ASSEMBLY & TESTING DEPT.

METALWORK DEPT.

MACHINES LOADING & SHIPMENT DEPT.

**Via Ponte a Iozzi 16/A,
50023 Cascine del Riccio
Impruneta, Firenze - Italy**



www.occemflorence.com